

IRR
ODI

THE INTERNATIONAL
REVIEW OF RESEARCH IN
OPEN AND DISTANCE LEARNING

Vol 6
No 3

November – 2005

Editorial – Well Balanced with an International Focus

Volume 6, Number 3 of IRRODL presents a well-balanced international focus with submissions from Sweden, Canada, USA, Oman, and Mauritius, and China. The issue promises an interesting read and hopefully serious study as we present nine main articles, two book reviews, three technical reviews, and two archived audio-graphic CIDER Sessions from IRRODL's publisher, the *Canadian Institute of Distance Education Research* (<http://cider.athabascau.ca>).

Main Section

The issue leads off with an excellent paper and call to action for researchers and theorist relating to systems theory in distance education. Steven C. Shaffer in *System Dynamics in Distance Education and a Call to Develop a Standard Model*, makes a soundly reasoned call for a standard model of distance education (DE). Drawing from the discipline of systems dynamics, Shaffer tell us that, "Systems thought in an educational context is problematic; authors sometimes write about looking at an educational situation from "a systems perspective," but then do not apply the tools and techniques of systems theory or system dynamics." We are long overdue for standard models for DE research and practice. Though 'systems thinking' does not reveal all of potential interest to distance educators, the demands for quality, cost and learning effectiveness that permeate much of our thinking suggests that systems models do have much to offer to both researchers and practitioners. Clearly, it is hard work applying standard models to messy world of human systems; doing so takes tremendous insight into both the intricacies of the system (DE in our instance) and the model (System Dynamics). I believe Shaffer has done an admirable job and has pointed researchers in a workable direction. For this we applaud his effort and suggest that we heed his call.

The next two papers come to us in a 'natural pair' focused on science education at a distance. The first is a case study by James Cheaney and Thomas Ingebritsen entitled: *Problem-based Learning in an Online Course*. Cheaney and Ingebritsen start off by reminding us that Problem Based Learning (PBL) uses 'real world' problems or situations as a context for learning. For this case study, the authors analyze an online biotechnology science course wherein students grappled with real life ethical, legal, social, and human issues surrounding pre-symptomatic DNA testing for Huntington's disease. Cheaney and Ingebritsen first provide evidence that suggests that PBL can stimulate higher-order learning in students. Unlike many studies of PBL use, however, this case study show that students' actual acquisition of knowledge was slightly lower for PBL students than for students who learned the same material via a traditional lecture format. The authors go on to explore the differences between the online PBL and lecture-based PBL, and suggests that further research on this topic is warranted.

The second science paper *Remote Access to Instrumental Analysis for Distance Education in Science* is co-authored by Dietmar Kennepohl, Jit Baran, Martin Connors, Kieron Quigley, and

Ron Currie. Here the authors report on a pilot study of a chemistry course that gave students' remote access to chemical experiments. Remote access (as opposed to virtual labs) allows students (at a distance) to actually manipulate scientific instrumentation and thus retain a critical 'hands-on' laboratory component of their chemistry course. Clearly, a strong laboratory component is at the heart of many successful science courses and the use of remote control in the 'real world' is happening here and now. This pilot found that student performance to be equivalent for the remote laboratory experience and for face-to-face experiments. The authors caution us, however, that the findings from this pilot cannot be generalizable, and thus other scenarios should be researched in greater detail.

Our next paper, *Teachers' Invisible Presence in Net-based Distance Education*, co-authored by Agneta Hult, Ethel Dahlgren, David Hamilton, and Tor Söderström, reports on a study illustrating that "the fusion of liberal education and online learning is more than the application of new terms to old practices." Hult and colleagues examine CMC and conversation using the Nordic construct of *folkbildning*, which translated means that people can mediate their own learning (i.e., auto-didactics). It is within the hundred year old Swedish concept of *folkbildning* that the authors examine the invisible role 'teachers' have in guiding student dialog in CMC mediated learning environments. I've attached quotes to the word 'teacher' here, because Hult and her colleagues assert that the term 'teachers' may no longer be appropriate. They then go on to explore alternative English words, such as 'supervision' or 'guidance,' which may still not accurately capture the relationship between teachers and learners in CMC mediated environments. They ask: "Can established practices be continued? Or must new forms of participation and group management be established?" They attempt to answer these questions by analyzing data from course postings and interviews; they arrive at the conclusion that online pedagogues are always present, yet in different – often invisible – ways. Ways that might better fit the Nordic construct of *folkbildning*.

In *Distance Higher Education Experiences of Arab Gulf Students in the United States: A cultural perspective* Aisha Al-Harathi reports on a study undertaken to provide cultural understanding about the nature of distance education experiences of Arab graduate students pursuing degree programs in the United States. Employing Hofstede's international difference dimensions and Hall's concept of low and high context cultures as her theoretical framework, Al-Harathi's analysis reveals cultural aspects related to Arab students' background. To date, very little research has been done on what is arguably a very important topic, and thus Al-Harathi's phenomenological work should provide a good springboard for further research in this area.

Shushita Gokool-Ramdoo examines the participation of women in online distance education courses in Mauritius from a qualitative and feminist perspective in her paper, *The Online Learning Environment: Creating a space for Mauritian women learners*. Her analysis of interviews with both female learners and their spouses, reveals the need for congruity and support in two social 'spaces' one related to marriage/family and the second to occupation. Given successful negotiation of pressures, support, and acceptance in these areas, Gokool-Ramdoo suggests that can "online learning can enhance and democratize women's access to education for personal development."

In her paper *Tensions in Learner Support and Tutor Support in Tertiary Web-based English Language Education in China* Tong Wang from Beijing discusses the tensions involved in providing adequate support for both learners and tutors in online English languages programs delivered in China. Wang's paper provides survey data quantifying the different needs, aspirations, and practices of both tutors and learners in the relatively new milieu of online

learning. The study reveals tensions between actual and espoused use and practices, and points to practices and policies needed to resolve these tensions.

In his paper *Effects of Linguistic Qualifiers and Intensifiers on Group Interaction and Performance in Computer-Supported Collaborative Argumentation*, Alan Jeong from Florida, USA uses quantitative analysis tools to measure the effect of linguistic qualifiers on response rates and on critical analysis. The technique illustrated in the article forces students to label their messages with one of four forms of linguistic identifier and then tracks the relationship between the type of message and response rate. The paper also looks more deeply within each message to quantify the number of qualifiers and intensifiers. From these quantitative results, Jeong concludes that “that qualifiers were used to hedge argument and that they should be discouraged during initial stages of identifying arguments.” As in the previous paper, gender differences are also examined. In sum, Jeong’s paper provides interesting results, practical suggestions, and suggests directions for further research for studies of online text interaction using learning activities focused on debate and effective argumentation.

Book Notes

In this issue, we bring to you two reviews of recently published books on distance education. First, IRRODL’s Regional Editor for Africa, Professor Rashid Aderinoye reviews *Distance Education and Languages: evolution and change*, edited by Börje Holmberg, Monica Shelley, and Cynthia White. Professor Aderinoye, who works for the Departments of Languages, University of Ibadan, Nigeria, offers a unique international take on this very worthwhile book.

Next, Heather Kanuka, Canada Research Chair in e-Learning reviews the much anticipated second edition of *Technology, e-Learning and Distance Education*, edited by Tony Bates.

Technical Evaluation Reports

We bid farewell and offer sincere thanks to Professor Jonathan Baggaley for his sponsorship, editing, and academic leadership of IRRODL’s Technical Reviews over the past three years. Jon has marshaled the talents and energy of students enrolled in the Master of Distance Education program at Athabasca University to produce a series of 53 indepth, multi-faceted technical reviews. Unlike most peer-reviewed journals in the field, IRRODL’s technical reviews have named names, compared prices and products, and served ably as a consumer’s guide to quality distance education educational technologies. In a field marked by rapid change and unfolding opportunity, these detailed technical analysis have provided the very necessary, but often difficult to find reviews, evaluations, and discussions untainted by pecuniary interests and/ or overt commercial bias. Dr. Baggaley’s final set of reviews looks at three conferencing products – two that support online synchronous audio discussion and a second comparison of three asynchronous text packages. We are pleased to welcome Dr. Patrick Fahy as IRRODL’s technical editor. In this role, Pat Fahy will continue to forge ahead and build upon the excellent work and contributions made by Jon Baggaley and Athabasca University’s Masters of Distance Education students.

CIDER Notes

IRRODL’s publisher, [*The Canadian Institute of Distance Education Research*](#), has just plunged headlong into its second season of CIDER Sessions. These increasingly popular CIDER Sessions

are archived and linked to IRRODL with the idea of broader dissemination of research activities beyond the Canadian research community. We hope you will take the time to download the [free Elluminate software](#) and listen to these two archived CIDER Sessions: [e-Portfolios: Promises & Pitfalls](#), by Natasha Boskic and Gabriella Minnes Brandes, from the University of British Columbia, and [The Influence of Instructional Methods on the Quality of Online Discussion](#), by Heather Kanuka, Canada Research Chair in e-Learning and Associate Professor, Athabasca University – Canada’s Open University.



November – 2005

System Dynamics in Distance Education and a Call to Develop a Standard Model

Steven C. Shaffer

The Pennsylvania State University, USA

Abstract

This paper describes systems dynamics, reviews the literature of uses of systems concepts in distance education (DE), presents a preliminary model, and ends in a call to researchers to contribute to the building of a standard model of DE.

Keywords: systems; systems theory; systems dynamics; models; theory; research

Systems Thinking

Systems theory, system dynamics, and similar phrases are often found in the literature of education, in general, and online education, in particular (Shaffer, 2004). There are two main strands of systems thought: systems theory and system dynamics. Systems theory was initially developed by biologist Ludwig von Bertalanffy (1968) as a rigorous method of describing the structure and mechanisms of organic systems. He was concerned about “the danger that general systems theory may end up in meaningless analogies” (p. 35) and was at pains to point out that “general systems theory is not a search for vague and superficial analogies” (p. 35). System dynamics (Forrester, 1968), the approach taken in this paper, comes out of the tradition of cybernetics research and is primarily focused on the dynamics of feedback loops, which, it is claimed, lie at the core of all real-world phenomena (Sterman, 2000). Sterman (1994) offers an excellent, detailed introduction to the use of systems theory in education.

Systems thought in an educational context is problematic; authors sometimes write about looking at an educational situation from “a systems perspective,” but then do not apply the tools and techniques of systems theory or system dynamics. In this paper I hope to clarify the possibilities for the use of system dynamics in the study of distance education.

Systems Dynamics

Sterman (2000) describes a dynamic system as one that inherently incorporates feedback loops. These loops are of two broad kinds, positive (self-reinforcing) and negative (damping). A common example of a positive feedback loop is any exponential growth situation – for example, a rabbit population grows exponentially in the absence of constraints (predators, food shortages, etc.), because each new generation adds to the previous generations (see Figure 1a). An example of a negative feedback loop is a boat pulling into a dock. While still a half mile away, the pilot

will make large vector adjustments to steer the boat toward the destination; as the boat approaches the dock, navigational changes will become smaller and smaller (see Figure 1b). Negative feedback loops exhibit the quality of damping (decreasing the amplitude of an oscillating system), which is characteristic of goal-driven systems.

Figure 1. Two types of feedback conditions

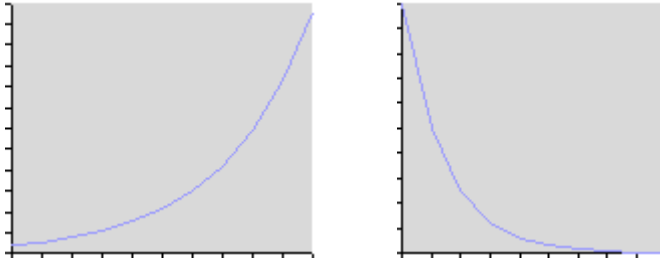

Each type of system change can be described by the following causal loop diagrams. Figure 2a shows a **positive reinforcement loop**, indicating the total number of bunnies increases as the number of newborn bunnies increases and vice versa. Figure 2b shows the **negative reinforcement loop** involved in docking a boat; as the pilot approaches the dock, the difference between the current position and the goal decreases; additionally, the amount of correction that the pilot needs to make also becomes smaller.

Figure 2. Positive and negative causal loop diagrams

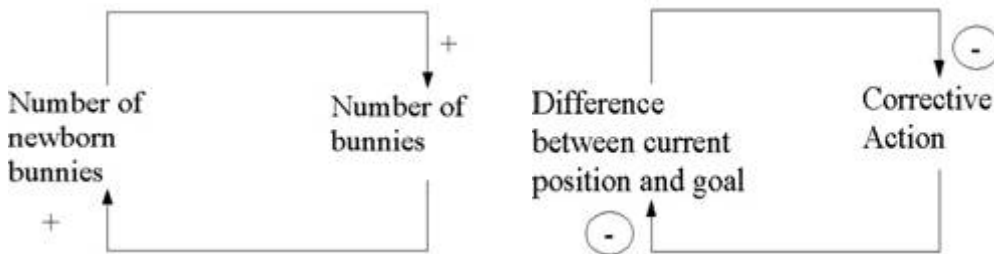

Figure 2a – positive reinforcement

Figure 2b – negative reinforcement

Real life is filled with such systems; the problem is that people do not make good inferences about even the simplest systems, even if given full information. Researchers have demonstrated this (Sterman, 2000, references specific studies) to the point that it has become a staple of organizational management seminars to demonstrate these results using simulation systems.

Adding to the complexity of any system is the human-in-the-loop, where the human is learning and thus changing the system dynamics. Most people operate in a single-loop learning mode (Figure 3a) – in this situation, the person adjusts his/ her decisions based on information feedback from the "real world," but often does not update his/ her mental models and/ or strategies. This mode can present itself as an obstinate "damn-the-torpedoes, full-speed-ahead" attitude. A more complex adaptive behavior is to adjust one's mental models and strategies as one processes feedback from experience. Thus, one might start a project with a simplistic view of the situation,

but adjust one's strategy as the complexity of the situation is realized. This mode is referred to as double-loop learning (Figure 3b).

Figure 3. Examples of learning loops – adapted from Sterman, 2000



Figure 3a – Single loop learning Figure 3b – Double loop learning

An important and confounding aspect of real-world systems is delay. There is always some delay in receiving feedback, but the longer that delay, the harder it is to operate effectively in it. In an educational context, feedback delay could manifest itself in wide swings in policy; for example, administration might fund a DE program, then cut funding too soon after launch, only later to re-fund the program and try again. The inability of policy-makers to wait long enough to see the results of their machinations is the cause of many strange human system behaviors, such as real estate boom/ bust cycles, stock market fluctuations, and aircraft pilot over-correction and oscillation.

Feedback is so pervasive that it is essentially *equivalent* to learning, as described for example in Vygotsky (1980, 1986). Apparently, though, most people are unable to process the entire complexity of even the simplest system. “The complexity of our mental models vastly exceeds our capacity to understand their implications” (Sterman, 2000, p. 37).

The best use of system models is in situations where controlled experiments are economically unfeasible, unethical, or impossible. The only way to work within complex contexts is to use what Sterman calls “micro-worlds”– simulations, models, etc., that allow us to “play” with the variables to see the results of various situations. Scientists and engineers do this all the time, as do airline pilots and architects. Simulations allow us to test and comprehend the complex forces under study in ways that we would not be able to without the simulations.

There is an important difference between theory and experiment, however. We need theory to help focus our experiments and draw the results of those experiments together. This is where simulations and models can be used, but they are not an alternative to experimentation, any more than piloting a 757 flight simulator is the same as actually flying the plane. At some point, we must step out of the arena of theoretical models and move into the world of experimental evidence; it is only by doing so that we will be forced to model those messy aspects of the real world situation that might not easily fit an elegant model.

Three Attributes of Social Systems for Modeling System Dynamics

Three aspects of social systems make them inherently “loopy,” and Sterman (2000) specifically deals with these:

Policy resistance happens when agents withhold participation in an established order because it is perceived to not be in their own best interests. A well-quoted reference to this phenomenon is President Harry Truman's statement regarding incoming President Dwight Eisenhower: “He’ll sit here, and he’ll say, ‘Do this! Do that!’ And nothing will happen. Poor Ike, it won’t be a bit like the Army. He’ll find it very frustrating” (Neustadt, 1960).

The *principle of bounded rationality*, states that the capacity of the human mind for handling complex problems is much smaller than the size of “real world” problems, and thus the standard economic assumption of a “rational decision maker” is flawed. It replaces the standard model with the notion of *satisficing*: the practice of selecting and accepting a goal or solution that is good enough within the confines of limited search time and inadequate information (Hellriegel, Slocum, and Woodman, 1995, p. 622).

The *law of unintended consequences* is the notion that, in the absence of full knowledge of the situation (i.e., always), decisions will have effects that were not anticipated.

Creating non-simplistic system models of social systems can help to ameliorate these types of problems by giving the analyst the tools needed to grasp the outcomes of policy decisions in complex situations. The challenge is to move from generalizations to specific actionable theories with high-probability predictable outcomes. It is important to note that one can only model problems, not entire systems, because the modeler must make decisions about what aspects of the problem are salient. Full models of complex systems would be as complex as the system itself and, therefore, of no use. This is not to say that significant portions of existing models cannot be “borrowed” within other contexts, just that it is not possible to create a one-size-fits-all model of any complex social system.

Review of Systems References in Educational Literature

According to Moore and Kearsley (1996), “It is not possible to improve quality, provide for more students, and lower costs without reorganizing education according to a systems model” (p. 7). With this in mind, the following is a review of literature on the use of systems concepts in education, starting with a brief review of a few key background references.

Considered the “father” of general systems theory, Von Bertalanffy (1968), wrote an early text that introduces the meaning and context of general systems theory (GST). Not overly technical, the book explains the genesis of the theory and describes its potential benefits to society. The author includes discussion of some of the holistic movements in various fields, such as physics (thermodynamics), psychology (Gestalt), and economics (planned economies). Our culture of specialists, he continues, is in need of generalists, but not people who simply know a little about a lot of things. Instead, what is needed are people who are well trained in a discipline that allows them to think in higher-level (more abstract) terms than is allowed for in most specialties. These people would be trained in

. . . models, principles, and laws that apply to generalized systems or their subclasses, irrespective of their particular kind, the nature of their component elements, and the relations or 'forces' between them . . . a theory, not of systems of a more or less special kind, but of universal principles applying to systems in general (p. 32).

Strauss (2002) analyzes system theory from the standpoint of several perennial philosophic questions: 1) the one versus the many (atomism versus holism); 2) the whole-parts relationship; 3) constancy versus change; and 4) entelechy, or vital force. Of particular interest for the present paper is the question of the ontological status of a system; that is, does a system exist, or do only the parts of the system exist? For example, a university is made up of people and buildings, but does the university itself exist as an entity? If so, in what way? From a philosophic standpoint, Strauss seeks to determine if systems such as universities, calculus, and pork-belly markets have an independent existence, and what exactly the nature of that existence is. The author defends a position somewhere between the platonic and the constructivist viewpoints: he disavows the notion of pre-existing categories or forms from which particular systems (e.g., universities and labor unions) get their individual existence, and he dismisses the constructivist notion that these systems only exist in the minds of the human perceiver. His position is built upon the notion that there are different types of systems, including, at least, mathematical, spatial, kinematic, and physical. His point is that any particular system may have aspects of more than one system type, which is why complex systems defy atomization. For example, a cell will certainly have biotic system aspects, but will also have physical (chemical, molecular) and spatial aspects.

Sterman (1994) provides an excellent introduction to the concept of system dynamics within the context of learning. He declares that “the challenge facing all is how to move from generalizations about accelerated learning and systems thinking to tools and processes that help us understand complexity, design better operating policies, and guide organization- and society-wide learning” (p. 292). Certain barriers to learning are described, including dynamic complexity, limited information, confounding variables and ambiguity, misperceptions of feedback, flawed cognitive maps and causal relations, and erroneous inferences about system dynamics. The use of simulations as a necessary aspect of learning is also discussed. For example, if one tries to elicit the knowledge of an expert in order to develop a curriculum, then

. . . regardless of the form of the model or the technique used, the results of the elicitation and mapping process is never more than a set of causal attributions, initial hypotheses about the structure of a system, which must then be tested. Simulation is the only practical way to test these models. The complexity of the cognitive maps produced by an elicitation workshop vastly exceeds our capacity to understand the implications (p. 321).

Frick (1995) applies systems theory to education and describes a plan to develop educational theory in a simulation environment. Drawing from the work of Maccia and Maccia (1966) who proposed 201 "hypotheses concerning relationships among properties of educational systems" (n.p.), Frick proposes to build software simulations of the complex interrelations within an educational system, and to use these simulations to help educators and administrators to introduce innovations into their systems.

The book chapter by Banathy and Jenlink (2004) discusses how systems approaches have been used in education; the authors refer to “the application of the intellectual technology of

comprehensive systems design as an approach to the transformation of education” (p. 47) and describe how system models should be used in education research and policymaking.

One of the best known treatments of systems theory in distance education is Moore and Kearsley (1994, 2005), who offer a single-tiered taxonomy of attributes of a distance education program under the title “a systems model for distance education” (2005, p. 14). Although they clearly have a systems view in mind, diagrams of this structure can not begin to capture the full complexity of the a DE system.

Anderson (2004) offers the beginnings of a theory of online learning. The author believes that any such theory would be premature at this point, but notes that “the creation of a model is often the first step toward the development of a theory” (p. 55). This online book chapter offers such a model, which combines attributes of learning with the “affordances” of the Internet, together with a theory of the role of interaction in online learning. Building from the work of Moore, Anderson elaborates on a model of the interaction between the three “agents” in educational interactions: teacher, learner and content, creating six possible interactions (learner-teacher, teacher-content, etc.). Next, he describes a more complex model that includes the “knowledge/ content interface” (p. 49) and aspects of communication and outside support. Generally, although the author does not use the phrase system theory, this model would be a good basis on which to build a system theory of online learning. As the author summarizes, “The model presented illustrates most of the key variables that interact to create online educational experiences and contexts” (p. 55).

Saba (1999) calls for a “systems theory of distance education.” Saba and Shearer (1994) attempt to lay the groundwork for a dynamic model of distance education that can be validated empirically. The authors state that “research in distance education has been primarily program based” (p. 36) and that the few empirical studies have measured factors such as stakeholder satisfaction. They propose that in order for the field of distance education to mature, there is a need for empirical studies to verify the conceptual foundations of the field, and that system dynamics allows for modeling and predicting future states and incorporating complex political, social, and economic forces. The paper includes a discussion of the use of system dynamics modeling software to create a non-simplistic model of distance education and to begin to validate certain assumptions in the model. As the authors note, the model is still too simple, but it lays the groundwork for future work in this area. Saba (2003) sees systems theory as “the quintessential (pragmatic) tool for understanding relationships between things and not looking for a single answer to a problem within the confines of a dogma” (p. 11).

Smith and Dillon (1999) contend that systems dynamics is necessary, though not sufficient, to develop an overall model of the distance educational processes: “. . . we argue that distance education must be examined as a system, but to do so requires looking at the system and the variables that make up the system, sometimes a few at a time” (p. 34). They make an important point: one cannot have an overarching theory without some data to construct it; however, my contention is that much research is published as disembodied pieces of information that lack coherence.

Luppini (2002) offers an overview of second-order cybernetic modeling, which “views knowing as a process of continual construction that maintains itself in the presence of (enabling or frustrating) perturbations from the medium in which it resides” (p. 93).

King and Frick (1999) present examples of using what they refer to as the SIGGS educational system modeling approach in two diverse educational settings: an elementary school classroom and a museum school. The authors discuss the complexity of the method and make an argument for its usefulness. Using their modeling approach, they demonstrate the differences between educational contexts and propose that the results of these educational situations could have been predicted from the model.

Some Objections and Some Replies

There are three common objections one encounters in conversation with educators with regard to using systems theory to inform educational practice. Each of these is briefly discussed below.

Reductionism: Sometimes systems theory is equated with a reductionist approach; this is a gross misconception. In fact, systems theory looks to model those aspects of reality which are not able to be captured in a hierarchical, reductionist framework. Modern physical science is very much taken up with non-reductionist approaches, as noted by the fact that systems theory was developed by the biologist von Bertalanffy for the very purpose of describing the complex, contextualized aspects of living systems. In my view, a tendency toward reductionism is the single largest obstacle to truly understanding the dynamics of education: variables cannot be both hierarchical and non-hierarchical within the same structure. Hierarchies are a result of reductionistic thinking. For example, even Saba, in his diagram 1.3 (Saba, 2003), while arguing for hierarchies, indicates interconnectivity among the myriad factors in multiple hierarchical levels, nullifying the very notion of those levels (which would require a single channel of input/output interaction).

Over-simplification: Another charge against systems approaches to studying education is that, as a social system, education is too complex to study this way. Yet, every organic process can be modeled, non-simplistically, as a complex set of input/output processes.

Behaviorism / associationism: Sometimes systems approaches are seen as a return to a behaviorist or associationist account of education. An important differentiation must be made between a strict associationism (with simple input-output pairs) and the assumption of a complex “black box,” which has inscrutable internal states (Haugeland, 2000). To the extent that we are warned against a strict associationism, this point is well taken; however, it seems possible to interpret this complaint as against modeling educational processes via their inputs and outputs, an approach that is central to all empirical research. If the alternative is to simply throw up one's hands and give up, then the only way to advance will be to recognize the possible pitfalls and move forward anyway.

I take the position that, at their base, DE variables are many and complex, and that attempts to restrain them into a hierarchy is only for our own ease of use and is eventually doomed to a false simplicity. Real-world systems are of a complexity that simple deterministic models (which were all that we could create before the advent of the computer) are doomed to fail. An obvious example of this is weather forecasting, which has made enormous strides during the last 25 years due in large part to the use of computer models (Ostby, 1999).

Developing a System Dynamics Model of Distance Education

DE research has uncovered, perhaps, one hundred or so variables. There is a tendency by researchers, when faced with a long list of variables, to attempt to sort the list into categories – this is a natural and useful tendency when dealing with, for example, a grocery shopping list. Thus categorized, the list is a useful reference when one is in the particular areas of the grocery store (produce, frozen food, etc.).

The trouble with categorizing the list is that educational variables are interconnected, unlike most grocery items. The concept of interconnected grocery items would be typified by the following rule: Buy frozen corn only if there is no fresh corn in the produce section. This rule becomes complicating if the frozen food section comes before the produce section in one's tour around the store – that is, during the first visit to the frozen food section, one does not know whether or not to pick up the frozen corn. The shopper has two possibilities: pick up the frozen corn and perhaps have to loop back to return it, or do not pick up the frozen corn and risk having to loop back and pick it up if no fresh corn is available in the produce section. The rule is an example of a simple coupling between variables, which would be hard to model if the list was broadly categorized as produce, frozen food, etc. In a DE context, such a rule might look like *only offer courses where enrollment is 10 students or greater* – there is obviously a time-delay aspect of this rule, which is impossible to capture in a static hierarchical model. Thus, our very tendency to use categorization to simplify a problem actually restricts the quality of our model. The tools of system dynamics give us the ability to handle the complexity of a problem without having to resort to power-reducing heuristics.

Modeling educational environments via system dynamics is not unheard of. Frick (1995), as discussed, puts forth a plan to develop computer software simulations of educational theory in an effort to help educators and administrators learn how to introduce innovations within their particular education systems. (See also King and Frick, 1999). If even mildly successful, such a tool would allow educational theorists and policy-makers to test out the results of their hypotheses and theories in ways that are (a) deeper than can be done via an “armchair” analysis alone, and (b) safer than testing theories on humans as a first draft. Such an approach has been used in the pharmaceutical industry for years; but it can never replace actual implementation with humans. Simulations can only help the researcher to focus on those ideas that have a higher potential for success.

Any model is an approximation; the art of modeling is incorporating all and only those things that are germane to the situation at hand. For this reason, system dynamics models can only be developed for specific situations – they do not allow for the creation of a “unified theory of everything.” Full models of complex systems would necessarily end up being as complex as the system itself.

DE can be well modeled via system dynamics, specifically because of the capacity of system dynamics to capture the small-changes-cause-large-effects nature of systems. If one breaks an educational system into, say, five easy pieces, that system will not be able to exhibit complex behavior, and thus any modeling of DE, for example, will stay encapsulated within its hierarchical category and not affect the system as a whole. By separately modeling dozens or hundreds of interacting variables within a system, however, it is possible to witness emergent behavior of the whole system. The notion of emergent behavior is central to current systems thinking (Crutchfield and Mitchell, 1994), but can only happen within the context of a system of

sufficient complexity. The collapse of the Tacoma Narrows Bridge in 1940 illustrates how a small factor can grow into a major changing force in an existing environment (see http://abel.math.harvard.edu/archive/21b_fall_03/tacoma/ for a video clip). A relatively small force of wind (35 – 46 mph) at the resonance frequency of the bridge caused the bridge to sway wildly and eventually collapse. At the time the bridge was built, engineers did not have a clear understanding of the complexity of forces at work on a suspension bridge; after the collapse, they learned more. With regard to education, it is my hope that we do not have to wait for a collapse before we learn more; for example, DE administration could model the effects of re-routing funding from one area to another and attempt to determine the effects before implementing the policy.

Time to Make a Standard Model — a call for participation

Many of us have become acutely aware that there is no accepted theory of anything in DE. There are many theories, but each new paper seems to come with permission to question or ignore everything that has come before (Moore, 2004). With the plethora of research that is available, it seems to me that we are ready to start sifting the wheat from the chaff.

I propose that the distance education community work together to create a model of what is known and/ or generally accepted in the field, and to hone the model by subjecting it to scrutiny and enhancement by volunteers. In many ways this project will emulate the open source movement in software development, where for example, Linus Torvalds created the kernel of Linux, and the rest of the program has been built by groups of volunteers improving on each other's work to make a cohesive whole (Weber, 2004). I propose a similar process for developing a DE model, and have created a web site called communityofscholars.net in which to collaborate on this project. In order to “kick start” this process, I propose the following preliminary model – absolutely no pretense of completeness or correctness is implied.

Preliminary Systems Model of the Socioeconomic Context of DE

Based to a large extent on Arai (1995) , I present a preliminary model of the socio-economic macro environment of distance education in Figure 4. (A full explanation of the justification of the model is available on the website.) The value of this model is twofold: (1) it tries to lay out the complexity of the economic relationships which form the environment of a distance education program and (2) it helps to focus research on distance education program design (more on this below). Several notational aspects of this diagram need to be explained: (a) non-shaded rectangles indicate aspects of the system which are not directly measurable; (b) non-shaded ovals indicate aspects of the system which are directly measurable; and (c) the two shaded areas indicate central foci for the following discussion. Also it is important to note that this model is not presented using causal loop diagrams because not enough information is yet available to make this practical. Each arrow in this model is an opportunity for research – we need to know what these relationships are and even if they exist or not.

Figure 4. Preliminary model of the socio-economic environment of DE

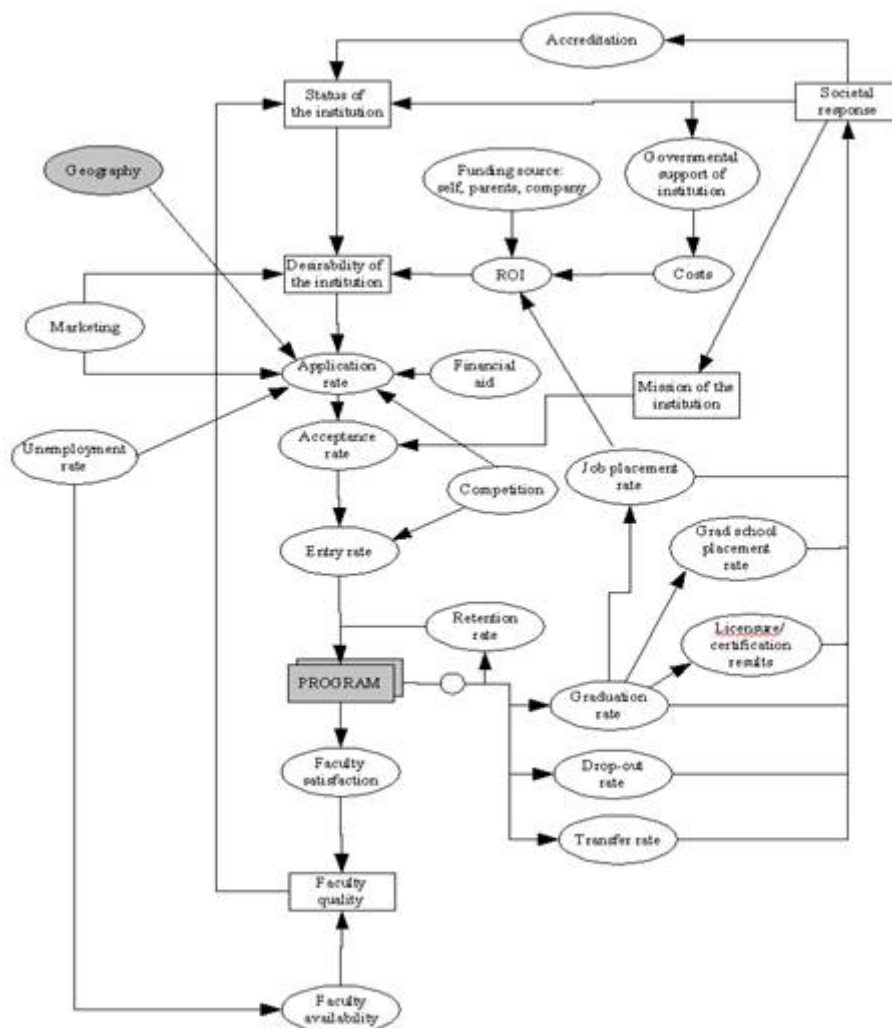

Important Implications of the Preliminary Model

One aspect of this model is that there is very little which makes it specific to distance education; in fact, the only difference is the notion of geography, which can be manipulated by adjusting the attribute parameters – making distance higher education equivalent to face-to-face instruction for the purposes of determining the macro-environmental influences. This has broad implications for DE research since, if this relationship holds, this means that all research in higher education at this level of abstraction will also apply to DE research.

Another important aspect of this preliminary model is that the notion of program has been abstracted out of the model. This means that particular aspects of a DE program can be seen to act as a “plug in module” for the model, which means that the internal aspects of a program do not directly affect the environment except through the five output variables shown (retention rate, graduation rate, drop-out rate, transfer rate and faculty satisfaction). These output variables – all of which are measurable – have a complex, dynamic relationship with the rest of the system and

thus these relationships are not easy to define. Some relationship between these program outputs and the single input to the program – entrance rate – can serve as a definition of the answer to the question is program x better than program y ? One should not assume that the measure of a good program is that it accepts many students, however, because this might lead to time-delayed consequences of moving the program into disfavor. This kind of dynamic can be seen when certain academic departments are well regarded and then slowly lose that regard based on administrative decisions made.

If the assumptions of this model hold, the ramifications for DE research are important: it will allow researchers who are interested primarily in program design and pedagogy to focus on the six variables (entry rate plus the five output variables) as the environmental inputs and outputs of the system. This will give DE program researchers a consistent means of comparing results.

However, this model is not sufficient; it is presented simply to give an illustration of what such a model might look like. Each relation – indeed attributes and relations that are not even shown – needs to be fully studied and a research-based consensus built regarding the status of each. As these relationships are identified and verified, the DE research community can stop re-creating theory with each new publication.

Conclusion

My goal is for the communityofscholars.net site to act as a conduit for the development of a system dynamics model of distance education, and each contributor will get equal billing on the project. I have laid out some initial ideas here and on the site, but these may be overridden by analysis and empirical data. This project is not entirely selfless; I strongly desire a more stable base of theory within which to perform my research. Can DE researchers work together to develop a non-trivial, standard model of the field? My hope is that we can; my intention is to report on our progress in periodic updates.

References

- Anderson, T. (2004). Toward a theory of online learning, in T. Anderson and F. Elloumi (Eds.) *Theory and Practice of Online Learning* (p. 33-60). Retrieved April 15, 2004 from: http://cde.athabascau.ca/online_book/
- Arai, K. (1995). *The Economics of Education: An analysis of college-going behavior*. Tokyo: Springer.
- Banathy, B. H., and Jenlink, P. M. (2004). Systems inquiry and its application in education. In D. H. Jonassen (Ed.) *Handbook of Research on Educational Communications and Technology* (p. 37- 57). Mahwah, NJ.: Lawrence Erlbaum.
- Crutchfield, J., and Mitchell, M. (1994). *The Evolution of Emergent Computation*. Santa Fe Institute Technical Reports. Santa Fe, NM.: Santa Fe Institute.
- Forrester, J. W. (1968). *Principles of Systems*. Cambridge, MA.: Productivity Press.

System Dynamics in Distance Education and a Call to Develop a Standard Model
Schaffer

- Frick, T. (1995). *Understanding Systemic Change in Education*. Retrieved August 2004, from: http://education.indiana.edu/ist/courses/r_695fric.html
- Haugeland, J. (2000). *What is Mind Design? In Mind Design II: Philosophy, Psychology, Artificial Intelligence*. Cambridge, MA.: MIT Press.
- Hellriegel, D., Slocum, J., and Woodman, R. (1995). *Organizational Behavior*. Minneapolis MN.: West.
- King, K., and Frick, T. (1999). Transforming Education: Case studies in systems thinking. Paper presented at the annual meeting of the *American Educational Research Association*, April 21-23. Montreal, Canada.
- Luppincini, R. J. (2002). Toward a conversation system modeling research methodology for studying computer-mediated learning communities. *Journal of Distance Education*, 17(2), 87 – 101.
- Maccia, E., and Maccia G. (1966). *Development of Educational Theory Derived from Three Theory Models*. Washington, DC.: U.S. Office of Education, project No. 5-0638. Retrieved October 7, 2005 from: <http://education.indiana.edu/~frick/edutheo.html>
- Moore, M., and Kearsley, G. (1996/2005). *Distance Education: A systems view*. Belmont, CA.: Wadsworth.
- Moore, M. (2004). Research Worth Publishing. *American Journal of Distance Education*, 18(3), 127 – 130.
- Neustadt, R. (1960). *Presidential Power: the politics of leadership*. Retrieved April 15, 2005 from: <http://www.bartleby.com/73/1514.html>
- Ostby, F. (1999). Improved Accuracy in Severe Storm Forecasting by the Severe Local Storms Unit During the Last 25 years: Then versus now. *Weather and Forecasting*, 14(8), 526 – 543.
- Saba, F., and Shearer, R. (1994). Verifying key theoretical concepts in a dynamic model of distance education. *American Journal of Distance Education*, 8(1), 36 – 59.
- Saba, F. (2003). Distance Education Theory, Methodology and Epistemology: A pragmatic paradigm. In M. Moore and W. Anderson (Eds.) *Handbook of Distance Education*, (p 3-20). Mahwah, NJ.: Lawrence Erlbaum.
- Saba, F. (1999). Toward a Systems Theory of Distance Education. *American Journal of Distance Education*, 13(2), 24 – 31.
- Shaffer, S. (2004). The Uses of Systems Theory in Distance Education: An annotated bibliography. *DEOS News* 13(7). Retrieved October 7, 2005 from: http://www.ed.psu.edu/acsde/deos/deosnews/deosnews13_7.pdf

System Dynamics in Distance Education and a Call to Develop a Standard Model
Schaffer

- Smith, P., and Dillon, C. (1999). Toward a Systems Theory of Distance Education: A response. *American Journal of Distance Education*, 13(2), 32 – 36.
- Sterman, J. (1994). Learning in and about complex systems. *System Dynamics Review*, 10(2-3), 291 – 330.
- Sterman, J. (2000). *Business Dynamics: Systems thinking and modeling for a complex world*. Boston, MA.: McGraw-Hill Irwin.
- Strauss, D. (2002). The scope and limitations of von Bertalanffy's systems theory. *South African Journal of Philosophy*, 21(3), 163 – 179.
- von Bertalanffy, L. (1968). *General Systems Theory: Foundations, development, applications*. New York: George Braziller.
- Vygotsky, L. (1980). *Mind in Society: The development of the higher psychological processes*. Cambridge, MA.: Harvard University Press.
- Vygotsky, L. (1986). *Thought and Language*. Cambridge, MA.: MIT Press.
- Weber, S. (2004). *The Success of Open Source*. Cambridge, MA.: Harvard University Press.



November – 2005

Problem-based Learning in an Online Course: A case study

James Cheaney and Thomas S. Ingebritsen
Iowa State University, USA

Abstract

Problem-based learning (PBL) is the use of a “real world” problem or situation as a context for learning. The present study explores the use of PBL in an online biotechnology course. In the PBL unit, student groups dealt with the ethical, legal, social, and human issues surrounding pre-symptomatic DNA testing for a genetic disease. Issues concerning implementation of PBL in the online environment are discussed, as are differences between online PBL and face-to-face PBL. This study provides evidence to suggest that PBL stimulates higher-order learning in students. However, student performance on a lower-level exam testing acquisition of factual knowledge was slightly lower for PBL students than for students who learned the same material through a traditional lecture-based approach. Possible reasons for this lower level of performance are explored. Student reactions and feedback to the PBL format yield more insight into issues surrounding the implementation of PBL in the online environment.

Keywords: problem-based learning; case-based learning; distance education; cooperative learning; genetic diseases; genetic testing, instructional design

Introduction

Problem-based learning (PBL), also known as case-based learning, is an increasingly integral part of education reform in the United States and around the world, especially in the medical and social sciences, and in pre-professional and professional programs (reviewed in Michel Bischoff, and Jakobs, 2002). While there is no universally-accepted definition of problem-based learning in the literature (Maudsley, 1999), the essence of PBL can be summarized as the use of a “real world” problem or situation as a context for learning (Morgan, 1983; Barrows, 1985; Boud, 1985; Duch, 1995; Domin, 1999; Michel et al., 2002). The purpose of PBL is to encourage student development of critical thinking skills, a high professional competency, problem-solving abilities, knowledge acquisition, the ability to work productively as a team member and make decisions in unfamiliar situations, and the acquisition of skills that support self-directed life-long learning, self-evaluation, and adaptation to change (Engel, 1991; Albanese and Mitchell, 1993; Ryan and Quinn, 1994). In PBL, this is achieved by using situations or problems presented in class that resemble reality. PBL is a student-centered constructivist approach to learning that facilitates the construction of a conceptual network of knowledge in students, which can then be applied in a wide range of practical settings (Creedy and Hand, 1994; Cruickshank and Olander, 2002). In many cases, the realistic problems used in PBL studies may not have a right or wrong answer. Instead, PBL works through five cognitive areas to stimulate learning:

Problem-based Learning in an Online Course: A case study
Cheaney & Ingebritsen

1. Activation of students' prior knowledge
2. Elaboration of prior knowledge through cooperative discussions
3. Restructuring of knowledge to fit the problem presented; construction of an appropriate semantic network through internal discourse
4. Learning in the scaffolding context of a real-world problem
5. Emergence of epistemic curiosity due to relevance of problem

(Schmidt, 1993)

In the PBL environment, students should be allowed to analyze the problem in its own and the student's context and environment (Coles, 1990, 1991) and to construct a method to arrive at a detailed analysis, if not a final conclusion (this process is sometimes referred to as "situation-based learning") (Dockett and Tegel, 1993; Russell, Creedy, and Davis, 1994). Care must be taken to ensure that students are not forced to follow one particular path to a predetermined conclusion (sometimes referred to as "solution-based learning" (Cowdroy, 1994); however, for an opposing viewpoint on the importance of actually solving the problem, see de Shazer, 1985). In PBL, the focus is on the process, not the product (Patel, Groen, and Norman 1991; Margetson, 1994; Shannon and Brine, 1994).

PBL is extremely consistent with constructivist philosophy. Constructivism (of which there are many different flavors) is, in the general sense, a Kantian philosophy (also heavily influenced by Descartes) which views knowledge as something the learner must uniquely construct for and by himself or herself in order to have a personal understanding of their own interaction with their environment (Kant, 1800/ 1974; Dewey, 1929; von Glaserfeld and Smock, 1974; Hilgard and Bower, 1975; Ryle, 1975; Blais, 1988; von Glaserfeld, 1989; Schmidt, 1993). Savery and Duffy (1995) identify three fundamental constructivist principles: understanding comes from our interactions with the environment (but not in the behaviorist stimulus-response fashion); cognitive conflict stimulates learning (expanded upon by Willingham, 2004); and knowledge evolves through social discourse and evaluation of the viability of individual understandings. All these principles are explicitly fulfilled through PBL. PBL instructors, as a result, become facilitators, coaches, and mentors, rather than the positivist stereotypical "fount of knowledge" (Collins, Brown, and Newman, 1989; Mullins, 1994; Russell et al., 1994; Mierson, 1998). PBL is pedagogically suited to many different types of constructivism, including Piagetian cognitive constructivism (Kanuka and Anderson, 1999), radical constructivism (in which PBL can be incorporated with cognitive apprenticeship) (Collins et al., 1989; Duffy and Bednar, 1991; Honebein, Duffy, and Fishman, 1993), situated constructivism (crisscrossing landscapes) (Spiro and Jehng, 1990; Molenda, 1991; Spiro, Feltovich, Jacobsen, and Coulson, 1991), and co-constructivism (in which PBL can be incorporated with reciprocal teaching) (Shunk, 2000).

PBL is typically conducted using cooperative learning groups (Anderson and Henley, 1994; White, 1996). Ideally, cooperative student learning groups should be as heterogeneous as possible to maximize the breadth of experiences and academic skills available to the group (Cuseo, 1996). Nevertheless, the PBL paradigm can provide sufficient scope for individual study disciplines to be developed (Navarra, Levin, and Navarra, 1993; however, the opposite viewpoint is implied by Tolnai, 1991).

PBL is usually conducted in a face-to-face setting. Less is known about the use of PBL in the electronic-based distance-education "virtual classroom," due to the relative novelty of electronic-based distance education. Klemm (2002) found that cooperative learning case study groups thrive in the electronic environment; however, Klemm's "case studies" were actually reviews of journal articles, and computer conferencing was used as an adjunct to face-to-face meetings between students in a traditional class. The Internet, however, allows a different kind of class experience that does not require students to ever meet each other in person. The versatility of the Internet, combined with its cost-effectiveness in overcoming the geographic limitations of the traditional university, presents educators with an unrealized potential to produce pedagogically- and scientifically-sound authentic learning experiences, including PBL, that allow for multi-disciplinary projects, cooperative learning groups, flexible scheduling, and authentic assessments in distance education courses. They may revolutionize, supplement, complement, and enrich science education, both at a distance and in the traditional college setting.

Design of the Problem-based Learning Unit and Assessment

A PBL unit has been used in several versions in an online undergraduate/ graduate course entitled "Biotechnology in Agriculture, Food and Human Health." This is a three-credit survey course that covers technology and applications of biotechnology as well as ethical, legal, and social issues (ELSI) associated with its use. When first conceived, the principal student market for the class was considered to be educators. Since then, however, the bulk of the students have been a mix of traditional undergraduate and graduate students majoring in molecular biology or genetics or working in an campus-based lab, professionals working for seed or other biotechnology companies (often these students have a business rather than a science background), and farmers who want to learn more about the seeds they are planting and harvesting. There have been other students from all walks of life, including military personnel, lawyers, engineers, and an assistant state secretary of agriculture. Students are geographically diverse, with nearly every U.S. state represented, as well as students logging in from Canada, Germany, and Kenya. The course is offered three times per year, and the number of students typically ranges from 15-30 students per semester, with a typical 25-30 percent drop rate between the beginning and end of the semester.

The course consists of online audiovisual lectures that are modeled after lectures in a face-to-face classroom (utilizing online slides accompanied by a streaming audio/ visual lecture), authentic learning assignments, and reading assignments in a required textbook and from various online resources. Approximately 60 percent of the grade in the course is based on authentic learning activities and the other 40 percent is from online exams based on content in the online lectures and reading material. Exams are password-protected and require the presence of an approved proctor (such as a county extension agent) to prevent student cheating. Within the class architecture, students can communicate with the instructor and with each other through an in-class email system, a bulletin-board-style discussion forum, and both private and public chat rooms.

We decided to use PBL pedagogy for a five-week unit about genetic testing technologies. One of the most interesting aspects of biotechnology are the ethical, legal, and social issues (ELSI) raised by these technologies. In the case of the genetic testing unit, one intriguing ELSI question is whether genetic testing is beneficial in a situation where there is no cure for the genetic disease. The PBL approach allowed us the use this interesting ELSI question to capture student interest and to motivate learning about the more technical aspects of the topic (nature of genetic diseases and genetic testing technologies).

Problem-based Learning in an Online Course: A case study
Cheaney & Ingebritsen

In the PBL unit, students are asked to think about a fictional 33-year-old man named Robert. Robert's mother died of an incurable fatal neurological genetic disease called Huntington disease (HD). Huntington disease is caused by a defect in a gene (HD, on chromosome 4) coding for a protein called 'huntingtin.' This defect is inherited in a dominant fashion (which means that inheritance of just one form of the abnormal gene usually leads to the development of HD). Thus, assuming there is no history in his father's side of the family, Robert has a 50 percent chance of having inherited the abnormal form of HD. Symptoms are classically manifested as progressive involuntary spasms and dementia. The age of onset is variable, but usually occurs between the ages of 15 and 60, depending on the severity of the defect. A review of more technical information about HD can be obtained from the National Center for Biotechnology Information's Internet site (<http://www.ncbi.nlm.nih.gov/entrez/dispomim.cgi?id=143100>).

Robert's mother began exhibiting HD symptoms at the age of 34, and survived for 16 years before succumbing at 50. Despite the lack of a treatment or cure for HD, there is a pre-symptomatic DNA test to determine the nature of a patient's HD gene. A positive result usually means the patient can look forward to an early and unpleasant death, and currently there is nothing he or she can do about it.

The ultimate student objective of the class activity is to make a decision about whether Robert should undergo pre-symptomatic DNA testing for HD. Student groups role-play various stakeholders in Robert's decision (such as Robert himself, his wife, his 4-year-old daughter, his employer, and his insurance company) and decide over the course of the unit through meetings, assignments, and research, whether to advise the man to take the test or not. The learning objectives for the PBL problem are as follows:

- Understand the nature and mode of inheritance of genetic diseases
- Gain an appreciation of the human cost of genetic diseases
- Understand the principles and technologies used in genetic testing
- Gain an appreciation of ethical, legal, and social issues associated with genetic testing
- Develop problem-solving skills
- Learn how to find and process information in Web-based databases

Assessment of authentic learning experiences is a controversial part of the literature surrounding PBL. It is difficult to devise a strictly objective means of assessing student performance in learning material. Assessments of authentic learning experiences must involve problems and provide opportunities where the complexity of the student's thinking process is exhibited (Wright, Millar, Kosciuk, Penberthy, Williams, et al., 1998). In the PBL unit that we are utilizing, assessment will be made through student performance on traditional exams consisting of a mix of multiple-choice and essay questions, the students' presentation of different aspects of the problem through the process of writing papers, and their ability to internalize their understanding of biotechnology methods and ELSI in order to devise a novel genetic test or a new means for Robert to approach his problem and decision.

The cooperative learning groups for this unit were assigned into groups ranging from 2-3 in some semesters to 3-4 in some semesters, based on the number of students enrolled in the class. Groups

Problem-based Learning in an Online Course: A case study
Cheaney & Ingebritsen

were assigned as to provide a mix of students taking the class for undergraduate or graduate credit. Groups were also assigned to provide a geographic mix, to prevent some groups from having an unfair advantage if they decided to meet in person (if all members lived, for example, in the same county), while other groups were limited to chat rooms, email, discussion forums, and other teleconferencing means. Geographic diversity in each group ensures that all groups must use the electronic means provided in the class architecture to hold meetings (though there was no attempt to prevent students from using external means of contacting their peers, such as standard email or instant messaging). No attempt was made to separate students by innate ability, as reflected by GPA or overall grade in the class.

Two versions of the PBL unit were tested. In the preliminary version of the PBL unit (which was used for only two semesters) there were three assignments (Defining the Issues, Gathering Information, and Solving the Problem), which served as guiding problems for the unit. In addition, both a pre-unit exam and a post-unit exam were utilized.

In the “Defining the Issues” assignment, student groups were asked to identify the issues involved in Robert’s decision and the types of information that will be needed for Robert to make an informed decision. Each group posted a summary of the ideas developed on the course discussion forum. Students were encouraged not to conduct research on HD (yet), or to reach a decision (yet) on whether Robert should have the genetic test done. According to the learning taxonomy developed by Bloom, Engelhart, Furst, Hill, and Krathwohl (1956), students were engaged in analysis of Robert’s situation and applying their own previous knowledge and values to some of the concerns he will be facing.

In the “Gathering Information” assignment, student groups were required to write a short research paper about HD. The paper included information about clinical features of the disease, information about the gene, the genetic defect and the mode of inheritance of the disease, and information about genetic testing for Huntington’s disease. Resources for the paper included online lectures and textbook reading assignments about genetic diseases and genetic testing technologies as well as Internet resources (e.g., molecular biology and genetics databases, informational websites). This assignment engaged students in comprehension of their research concerning HD and their ability to synthesize that research into a comprehensive whole.

In the “Solving the Problem” assignment, student groups used a structured decision-making process to decide whether the individual should be tested for the genetic disease. The decision-making process involved identifying the stakeholders, brainstorming about possible options, considering the effect of various options on all of the stakeholders, and finally choosing the “best” solution. Students then wrote a report on this decision, focusing on the logical defense and reasoning for their opinion. Students were not graded on their opinions per se, but on the persuasiveness and completeness of their arguments. Students applied their knowledge to the final situation and synthesized an appropriate response considering the varied and diverse concerns of the various stakeholders. In justifying their final recommendation, students evaluated the various arguments for and against Robert having the test done and all the variations thereof (such as when Robert should have it done, who should be involved in the decision, and so forth), and argued in defense of their decisions. These arguments reflected their own construction of values based on their research, while recognizing those arguments’ inherent subjectivity. According to Bloom and colleagues (1956), therefore, the “Solving the Problem” assignment can be classified under the application, synthesis, and evaluation domains.

Problem-based Learning in an Online Course: A case study
Cheaney & Ingebritsen

Exam questions were taken from a test bank with several possibilities for each question. One possibility for each question was picked randomly by the examination software for the pre-unit exam and again for the post-unit exam. This ensured that questions were similar in difficulty for the pre-unit exam and the post-unit exam, and yet minimized the likelihood of students seeing the same question more than once. Exam questions tested understanding of inheritance patterns of genetic diseases and specific DNA technology techniques used in diagnosis of genetic diseases.

A problem with the preliminary version of the PBL unit was the narrow focus on just one genetic disease (HD). Because of this the unit was revised by replacing the “Gathering Information” assignment with two other assignments, “Genetic Diseases” and “Genetic Testing”, which gave the students a broader view of genetic diseases and DNA-based diagnoses. The other two assignments, “Defining the Issues” and “Solving the Problem,” were used unchanged in the final version of the PBL unit. To date, this PBL unit has been used for 13 semesters.

In the “Genetic Diseases” assignment, students chose a genetic disease from a list of genetic diseases available at a National Institutes of Health (NIH) website. They were required to do research on the Internet in order to answer a set of specific questions about the disease and the characteristics of its manifestation, and the gene and genetic mutation associated with this genetic disease. The assignment was conducted as an individual student assignment. This assignment tests student comprehension of information gained from their research. This assignment also provides students with a background in other genetic diseases that can sometimes be manifested in added evaluation abilities when, in the “Solving the Problem” assignment, some students compare and contrast HD with the disease they picked for this assignment.

In the “Genetic Testing” assignment, the students are asked to design a novel pre-symptomatic genetic test for a fictional genetic disease, based on their understanding of DNA technologies used for genetic diagnoses. Resources for the two assignments included online lectures about genetic diseases and genetic testing technologies, textbook reading assignments and Internet resources. Unlike “Genetic Diseases,” “Genetic Testing” was a group assignment testing their ability to synthesize a test using real technology for a fictional genetic defect.

The PBL unit was worth 28 percent of the final grade in the course. Student assessment was based on written assignments (2/3 of grade) and a post-unit exam (1/3 of grade). The pre-unit exam was discontinued for the final version of the PBL unit. The test bank for post-unit exam questions was unchanged from that used in the earlier version. There was an added question in the post-unit exam about the legality of an action by Robert’s employer or insurance company predicated on his testing positive for HD. This question required students to research the legal basis for their answer online (so this question is referred to as the “open book” section, even though there is no physical book involved in the students’ research for this particular question). Table 1 summarizes the main characteristics of the two versions of the PBL unit.

Table 1. Summary of characteristics of two versions of PBL unit used in biotechnology course

<u>Preliminary Version</u>	<u>Final Version</u>
<ul style="list-style-type: none"> • Text-based PBL problem 	<ul style="list-style-type: none"> • Text-based PBL problem
<p><i>Student Assessment</i></p> <ul style="list-style-type: none"> • Guiding assignments (all done in groups) <ul style="list-style-type: none"> ○ Defining the Issues ○ Gathering Information ○ Solving the Problem • Exams (all completed individually; all "closed book") <ul style="list-style-type: none"> ○ Pre-unit exam ○ Post-unit exam 	<p><i>Student Assessment</i></p> <ul style="list-style-type: none"> • Guiding assignments <ul style="list-style-type: none"> ○ Defining the Issues (group) ○ Genetic Diseases (individual) ○ Genetic Testing (group) ○ Solving the Problem (group) • Exam (completed individually) <ul style="list-style-type: none"> ○ Post-unit exam ("closed book") ○ "Open book" section
<p><i>Student Evaluations of Unit</i></p> <ul style="list-style-type: none"> • How did we accomplish the student learning objectives? (6 questions) • We would like you to rate the effectiveness of the assignments in this component. (3 questions) • What did you like best about this unit? (anecdotal) • What did you like least about this unit? (anecdotal) • Other comments about this unit? (anecdotal) 	<p><i>Student Evaluations of Unit</i></p> <ul style="list-style-type: none"> • How did we accomplish the student learning objectives? (6 questions) • We would like you to rate the effectiveness of the assignments in this component. (4 questions) • What did you like best about this unit? (anecdotal) • What did you like least about this unit? (anecdotal) • Other comments about this unit? (anecdotal)

Evaluation

The preliminary version of the PBL unit utilized a pre-unit exam to test student knowledge and understanding of genetic diseases and genetic diagnosis technology before beginning the PBL unit. Students who completed the exam received extra credit points, equivalent to just under 0.3 percent of the total points possible for the entire course. When pre-unit exam scores are compared to the scores for the exam administered after the PBL unit (which was a required exam equivalent to 12 percent of the total points possible for the entire course), a measure of the increase of student factual knowledge can be determined. This comparison was conducted using Student's t test (Steel and Torrie, 1960). The average scores on the pre-unit exam ($47.0\% \pm 19.2$; $n = 20$) and the post-unit exam ($79.7\% \pm 18.2$; $n = 20$) were significantly different ($P = 3 \times 10^{-6}$), indicating a significant increase in factual knowledge.

Students who completed the final version of the PBL unit had lower exam scores than those who had completed a unit covering the same material using a lecture-based instructor-centered approach, based on a very similar multiple-choice-and-essay post-unit exam ($P = 0.016$; see Table 2 for results). The lower exam scores for the PBL students represented a difference of one half of a letter grade for the exam. It is possible that the students that completed the lecture-based approach were more proficient overall due to previous exposure to biotechnology theory and laboratory work, so overall grades for the entire course were compared between these two groups. No significant differences in overall grades were found ($P = 0.620$; see Table 2).

Problem-based Learning in an Online Course: A case study
Cheaney & Ingebritsen

Table 2. Scores for post-unit exam, overall grade for course, and assignments used in PBL format for genetic diagnosis unit compared to scores using lecture-based format for genetic diagnosis unit.

All scores are based on a maximum score = 100.

Comparisons analyzed using 2-tailed Student's *t* test.

N.A. = assignment not used in lecture-based format, so comparison cannot be made.

a = Assignment completed individually.

b = Assignment completed in cooperative learning groups of 2-3 to 3-4 students.

* = statistically significant ($P < 0.05$).

<u>Assignment</u>	<u>Score using PBL unit (final version) \pm SD (n)</u>	<u>Score using lecture- based format \pm SD (n)</u>	<u><i>P</i></u>
Post-unit Exam ^{a*}	80.2 \pm 14.8 (227)	84.9 \pm 12.1 (53)	0.016*
Overall Grade for Course ^b	84.6 \pm 10.7 (227)	85.5 \pm 12.6 (54)	0.620
Genetic Diseases ^a	91.3 \pm 8.1 (249)	N.A.	N.A.
Genetic Testing ^b	85.5 \pm 11.8 (96)	N.A.	N.A.
Solving the Problem ^b	89.7 \pm 9.1 (99)	N.A.	N.A.

Assignment scores are summarized in Table 2. The lower n values for the “Genetic Testing” and “Solving the Problem” assignments represent each cooperative learning group being treated as an experimental unit (the “Genetic Diseases” assignment and the exams were completed individually). Based on the grading criteria discussed previously, it is reasonable to assume that, despite their subjective nature, the learning objectives of the unit were fulfilled, with excellent consideration demonstrated by student groups in general in consideration of Robert’s options and the impact each has on their stakeholder. Assignment scores for “Defining the Issues” were not statistically analyzed due to different grading criteria being adopted for this assignment as the study progressed.

In any learning situation, student attitudes greatly influence the degree to which learning can occur (Henderleiter and Pringle, 1999). Student attitudes were determined using their responses to questions posed on the end-of-semester student evaluations concerning the PBL unit. These questions are listed in Table 1. Results for the questions asking about the learning objectives and the assignments themselves are summarized in Table 3. In anecdotal comments about what students liked most and least about the PBL unit, students indicated that they appreciated the independent research (when the division of labor with their groupmates was successful), exploring the World Wide Web, learning about Huntington disease and other genetic diseases, and communicating with other students about the problem. The cooperative learning aspect of the PBL offered students experience in time management, schedule coordination, and division of labor. Some students, however, expressed concerns about scheduling difficulties for synchronous electronic meetings with their cooperative groups, and the technical difficulties inherent in an online setting (such as Internet lag, computer crashes, or bandwidth or browser problems). In addition, group activities decrease some of the temporal and geographic flexibility advantages that asynchronous online courses offer.

Table 3. Student evaluation ratings in response to the problem-based learning unit in an online biotechnology class. Ratings are based on a scale of 1 (excellent) to 5 (poor)

	Rating Average \pm SE	n
How well did we accomplish the following learning objectives:		
1. Understand the nature and mode of inheritance of genetic diseases	1.77 \pm 0.70	166
2. Gain an appreciation of the human cost of genetic diseases	1.63 \pm 0.67	166
3. Understand the principles and technologies used in genetic testing	1.75 \pm 0.73	165
4. Gain an appreciation of ethical, legal, and social issues associated with genetic testing	1.75 \pm 0.80	166
5. Develop problem solving skills	2.17 \pm 0.88	166
6. Learn how to find and process information in Web-based databases	1.95 \pm 0.96	38
We would like you to rate the effectiveness of the assignments in this component.		
7. Defining the issues	2.15 \pm 0.91	166
8. Genetic Diseases	1.86 \pm 0.75	166
9. Genetic Testing	2.02 \pm 0.82	166
10. Solving the problem	2.24 \pm 0.93	164

Discussion

A major difference between PBL in a traditional face-to-face learning environment and in an online learning environment is the way in which group members interact with each other. In traditional PBL groups typically meet face-to-face in or outside of class time. In the online environment all meetings take place electronically. These meetings may occur synchronously using the telephone, text-based chat or audio/ video conferencing or asynchronously using discussion forums or email. There are strengths and weaknesses to each of these approaches.

Synchronous communication technology provides for spontaneity and give-and-take between group members with immediate feedback. A problem with this approach is the difficulty of scheduling synchronous meetings. This is especially true for non-traditional students. Another problem with synchronous communication is the clunkiness of text-based chat. Problems here include typing abilities (especially speed) and the ability to decipher multiple simultaneous threads of conversation. Audio- or videoconferencing is a superior approach for synchronous communication, but it is not applicable in our situation because we have chosen to restrict the course to low bandwidth technologies (i.e., phone/ modem) in order to make the course as widely accessible as possible.

Asynchronous interaction provides more time for the individual research required for to a student to fulfill his or her role in the group, and also stimulates reflection on the relevant issues the group is discussing. Asynchronous interaction, however, often inhibits spontaneous development of ideas. A student may also make significant progress down the “wrong path” through research before his or her teammates can correct an improper understanding of that student’s role in the group for that particular assignment. In addition, asynchronous interaction inhibits the quick allocation of tasks and formation of schedules to get problem-solving activities completed (Garrison and Anderson, 2003).

Problem-based Learning in an Online Course: A case study
Cheaney & Ingebritsen

When the PBL unit was first included in this course, student interaction was generally evenly balanced between asynchronous communication (discussion forums) and synchronous communication (chat room, telephone). As the semesters passed, the use of the chat rooms within the course architecture decreased steadily, while the use of the asynchronous discussion forums increased steadily. This was due in part because we promoted the use of asynchronous technologies by establishing private discussion areas for each group and by encouraging them to meet asynchronously in our initial instructions. We did this so that we could more effectively monitor group interactions. Additionally we have noted anecdotally that, while the proportion of non-traditional to traditional students has remained relatively constant, it now seems that nearly all of our traditional students are working their way through college, as well as non-traditional students. It is thus much harder to schedule synchronous meeting times that agree with the schedules of everybody in the cooperative group. With the widespread advent of email in the late 1990s and early 2000s, students are also much more comfortable with asynchronous communication.

Another difference between distance PBL and face-to-face PBL is the role of the instructor. In PBL the instructor serves as a facilitator who gives feedback, challenges students' understanding of concepts without dominating the group, monitors group dynamics, manages conflicts, knows when and when not to intervene, and empowers students (Mierson, 1998). The role of the instructor as facilitator is more difficult and time-consuming in a distance-education PBL setting than in a face-to-face PBL setting, because the instructor must rely on student self-reporting to identify dysfunctional groups (especially if the group is communicating mostly by private means such as email or chat rooms), or must monitor the group's discussion forum. Sometimes students must be prodded by the instructor to report on their own group dynamics. In our study, several assignments, such as "Defining the Issues," had a small point value given to discussions about their own group dynamics, whether students were equally sharing the division of labor and writing duties with their peers, and so forth.

Another consideration that is especially important in distance education is that of student motivation. Wankat and Oreovicz (1991) identify two forms of motivation, intrinsic (internal pleasure from the intellectual challenge of learning, social interaction, and so forth), and external (grading, encouragement from the instructor, etc.).

An online distance education requires a great deal more intrinsic motivation than a traditional face-to-face course. Rather than having a set-aside time for students to focus exclusively on their learning by going to class, the learning experience is brought to the student's home where it must compete against family obligations, social interruptions, housework, and entertainment. Many students report motivation as a prime difficulty in their evaluations at the end of the semester. The main extrinsic motivation (grading) leads to procrastination followed by cramming, but in distance-education PBL, where students must schedule working on the problem around the schedules of their groupmates, procrastination is not possible without leading to an unequal division of labor – and, indeed, procrastination by one member of a group often turns out to be the root cause of many dysfunctional groups. Assignments (extrinsic motivation) must be made due at periodic intervals (we have assignments due at one-week intervals through the five-week PBL unit) to maintain that extrinsic motivation, which helps support students' intrinsic motivations, and to help prevent procrastination.

A major goal of the PBL unit was to promote higher-order learning – application, analysis, synthesis, and evaluation in the taxonomy of Bloom et al. (1956). Assignments for the PBL unit

were designed to evaluate higher-order learning of the human cost and ELSI of genetic diseases and genetic testing. Despite the necessarily subjective nature of the grading process, the reports by the student groups indicate a high level of comprehension of research (“Genetic Diseases”), analysis of relevant issues (“Defining the Issues”), synthesis of ideas in response to a novel situation (“Genetic Testing”), and application and evaluation of resulting principles to the central core question (“Solving the Problem”) within the group. Students integrated their learning of material from this course with their individual background and experiences, fusing their ideas to a common consensus within the student groups. This is consistent with Wright and colleagues (1998), who found when dealing with student-centered cooperative active learning that differences in perceived student competence and “student maturity” are correlated with the authentic development of higher-level thinking skills. Another study found that medical students who completed PBL-intensive medical training scored significantly higher than their colleagues who had experienced a mostly-lectured-based curriculum in five areas relating to humanism and social learning, were much more likely to have pursued careers in primary care or psychiatry (as opposed to, for example, surgery or research), and were more likely to believe that their training continued to influence their thinking (Peters, Greenberger-Rosovsky, Crowder, Block, and Moore 2000). This indicates a greater understanding of the ELSI and human issues through PBL.

What is the impact of PBL on lower-level learning (knowledge and comprehension of factual information)? Does the process of knowledge construction inherent in PBL compromise the acquisition of factual knowledge that is central to science? We addressed this question using exams which measured students’ knowledge and comprehension of the basic factual information about genetic diseases and genetic testing. Comparison of pre-module and post-module exam scores indicates that significant factual knowledge is acquired through the PBL format, just as it is in a lecture-based format. The post-exam scores for the PBL format, however, were a half grade lower than the post-exam scores when the material was taught using conventional pedagogy. This effect was specific for the PBL unit and was not seen when comparing overall course grade. This suggests that low-level learning may be somewhat compromised using the PBL approach. A note of caution here is that the pre-PBL sample size was relatively small ($n = 53$) and may not be representative.

Why might students score lower on exams testing low-level knowledge and comprehension with the PBL format? Wankat and Oreovicz (1991) propose that learning takes place when a student is presented with information in such a way as to cause disequilibrium. Failure to achieve this disequilibrium may cause a student to feel complacent, and there is no motivation to learn. A student in a state of disequilibrium feels a need to ease his or her intellectual discomfort, and is thus motivated to do something. In other words, in order to learn, students must first understand what they don’t know (Bransford and Schwartz, 1998). In the process of learning, a student construct an intellectual scaffolding with supporting concepts that allows him or her to return to equilibrium.

In this study, the students generated their own disequilibrium by completing the “Defining the Issues” assignment, where they acknowledged the information Robert would need to accumulate in order to make an informed decision. Not only would they need to learn much more about the human issues and ELSI surrounding Robert’s dilemma, but they would also need to learn much more about the characteristics of genetic diseases and the techniques used in genetic testing. The instructor is responsible for facilitating student access to the information available that will allow the student to begin to construct an intellectual framework; however, the instructor should be careful not to provide too little support (which makes the student feel lost) or too much support (which gives the student no reason to actively participate in his or her own learning) (Erlendsson,

2001). This is more difficult in an online class where an instructor does not have face-to-face contact with students, and more difficult in a PBL setting where students are searching to develop their answers largely on their own. Intimidation by the immensity and complexity of the electronic Internet may also be a factor (Jensen Guttschow, and Hill, 2002). It is possible in our case that the PBL format may be so alien to students who are veterans of a more traditional format, that they struggle in an environment where they, rather than their instructor, directs their learning (Cruickshank and Olander, 2002). PBL requires much more motivation on the student's part, as well as more work outside of class (Herreid, 2000). Time constraints may play another factor. While completing the unit, students are focused on the immediate goal of completing the assignments, which are geared to higher-order learning. If the development of higher-order understanding by the students is a goal however, then assessment should be in the form of problems and opportunities that demonstrate the complexity of the student's thinking process (Wright et al., 1998). Performance on a traditional multiple-choice exam reflects only low-level command of the subject matter, not the high-level understanding that is the focus of PBL. The literature, however, indicates no differences in gains of student understanding of factual material through PBL compared to a traditional lecture-based and instructor-centered setting (Dyke, Jamrozik, and Plant, 2001).

In evaluations of this unit, students appreciated many of the advantages of working together with their teammates to develop answers to the problems presented, such as "being able to bounce ideas off" their teammates. PBL also has the advantage of reducing the sense of isolation, which reduces motivation that pervades much of distance education. Students did take special notice of inherent cooperative learning disadvantages, such as problems in coordinating schedules that are also present in real-world teamwork. There are also disadvantages common to all online ventures (i.e., technical problems such as Internet lag, computer crashes, and other software or hardware problems), and disadvantages unique to PBL and/ or cooperative learning in an online setting (i.e., decreases in temporal and geographic flexibility; differences in feedback, compromise ability, and timeliness between students within a group). These difficulties have been noted by other researchers, who suggest that improvements in the support network (i.e., computer software) might help students better manage the division of labor, scheduling, and management of documents chronicling the development of their thoughts (Garrison and Anderson, 2003).

Conclusion

PBL has been effectively used to promote higher order learning in many disciplines in a face-to-face environment. We wanted to know whether this pedagogy would also be effective in an online environment. Our results indicate that higher-order learning and construction of understanding of the science and ELSI of genetic testing is taking place through the use of this PBL environment. Student reaction to the course was generally positive, but with some reservations about the effectiveness of group work in an online class.

Is virtual PBL a viable pedagogy in other online courses? There is a substantial body of research showing that there is no significant difference in learning between the Internet-based and face-to-face educational environments (reviewed in Russell, 2001). Is the use of PBL in the online environment any different? There are obvious differences between face-to-face PBL and online PBL with regards to cooperative communication (asynchronous vs. synchronous), scheduling, interpersonal relationships, student motivation, timeliness, and technical problems with hardware, software, or infrastructure. We feel, however, with student performance on this unit that the advantages of the cooperative PBL format, such as increased higher-order learning and deeper

student understanding, balance the disadvantages experienced by certain students and student groups. It is our belief that PBL is a valid and valuable means of increasing student learning in any online class where higher-order learning is desirable.

We found that there was a small, but statistically significant, difference in lower level learning as measured by an exam at the end of the unit. It is not clear whether this is an inherent feature of PBL in an online environment or whether it is simply a feature of this particular case. There is extensive literature showing that there is no significant difference between lecture-based student performance and PBL student performance on standardized exams (Wright et al., 1998; Dyke et al., 2001; Cruickshank and Olander, 2002; Michel et al., 2002). However, standardized exams are specifically designed to test knowledge of the type that is easily conveyed through a lecture-based format. Wright et al. (1998) and Michel et al. (2002) suggest that the strength of PBL is not measured by student performance on multiple-choice exams, but by demonstration of higher-order learning through guided authentic learning activities.

A factor that may influence student learning is the sense of connection – or lack thereof – to the central problem that the students face. The PBL unit in this study is text-based, but could be re-contextualized to be more integrated, thus transforming the online delivery of this PBL unit from being oriented towards a technical imperative to being oriented towards a pedagogical imperative (Oliver and Harrington, 2000). In other words, the PBL unit could be made more immersive for students by using seamless access to resource material such as streaming multimedia that takes them intimately into Robert's world. Immersion transforms the PBL situations, such as Robert's dilemma, from an abstraction into a context "within which a particular situation is perceived, interpreted, and judged" (Broudy, 1976). Work is in progress to explore the effects of adopting an immersive multimedia-rich environment on fulfillment of the learning objectives of this PBL unit.

Acknowledgements

The authors wish to thank M. Duane Enger for his helpful comments on the manuscript. This work was supported in part by a grant from the Computer Advisory Committee of the Iowa State University College of Liberal Arts and Sciences.

References

- Albanese, M. A., and Mitchell, S. (1993). Problem-based Learning: A review of literature on its outcomes and implementation issues. *Academic Medicine* 68, 52 – 81.
- Anderson, P., and Henley, I. (1994). Problem-based learning and the development of team skills in aviation studies. In S. E. Chen, R. Cowdroy, A. Kingsland, and M. Ostwald (Eds.), *Reflections on Problem Based Learning* (p. 319-345). Sydney: Australian Problem Based Learning Network.
- Barrows, H. (1985). *How to Design a Problem-Based Learning Curriculum for the Preclinical Years*. New York: Springer.
- Blais, D. M., (1988). Constructivism: A theoretical evolution in teaching. *Journal of Developmental Education*, 11(3) 2 – 7.

Problem-based Learning in an Online Course: A case study
Cheaney & Ingebritsen

- Bloom, B. S., Engelhart, M. D., Furst, F. J., Hill, W. H., and Krathwohl, D. R. (1956). *Taxonomy of Educational Objectives: Part I, Cognitive Domain*. New York: McKay.
- Boud, D. J. (1985). Problem-based learning in perspective. In *Problem-Based Learning in Education for the Professions*. Sydney: Higher Education Research and Development Society of Australasia.
- Bransford, J. D., and Schwartz, D. L. (1998). Rethinking transfer: A simple proposal with multiple implications. *Review of Research in Education* 2(4), 61 – 100.
- Broudy, H. S. (1976). Types of knowledge and purposes of education. In R. C. Anderson, R. J. Spiro, and W. E. Montague (Eds.) *Schooling and the Acquisition of Knowledge* (p. 1-17). Hillsdale, NJ.: Lawrence Erlbaum Associates.
- Coles, C. R. (1990). Evaluating the Effects Curricula Have on Student Learning: Toward a more competent theory for medical education. In Z. M. Nooman, H. G. Schmidt, and E. S. Ezzat (Eds.) *Innovation in Medical Education: An Evaluation of Its Present Status* (p. 76-87). New York: Springer.
- Coles, C. R. (1991). Is problem-based learning the only way? In D. Boud and G. Feletti (Eds.) *The Challenge of Problem-Based Learning* (p. 295-307). London: Kogan Page.
- Collins, A., Brown, J. S., and Newman, S. E. (1989). Cognitive Apprenticeship: Teaching the crafts of reading, writing and mathematics. In L. B. Resnick (Ed.) *Knowing, Learning, and Instruction: Essays in Honor of Robert Glaser* (p. 453-494). Hillsdale, NJ: Lawrence Erlbaum Associates.
- Cowdroy, R. M. (1994). Concepts, Constructs and Insights: The essence of problem-based learning. In S. E. Chen, R. Cowdroy, A. Kingsland, and M. Ostwald (Eds.) *Reflections on Problem Based Learning* (p. 45-56). Sydney: Australian Problem Based Learning Network.
- Creedy, D., and Hand, B. (1994). Determining changing pedagogy in PBL. In S. E. Chen, R. Cowdroy, A. Kingsland, and M. Ostwald (Eds.) *Reflections on Problem Based Learning* (p. 141-156). Sydney: Australian Problem Based Learning Network.
- Cruickshank, B. J., and Olander, J. (2002). Can problem-based instruction stimulate higher order thinking? *Journal of College Science Teaching* 31(6) 374 – 377.
- Cuseo, J. B. (1996). *Cooperative Learning: A Pedagogy for Addressing Contemporary Challenges and Critical Issues in Higher Education*. Stillwater, OK.: New Forums Press and the Professional and Organizational Network in Higher Education.
- de Shazer, S. (1985). *Keys to Solution in Brief Therapy*. New York: Norton.
- Dewey, J. (1929). *The Quest for Certainty*. New York: Minton.

Problem-based Learning in an Online Course: A case study
Cheaney & Ingebritsen

- Dockett, S., and Tegel, K. (1993). "But we was just turtles:" Situation-based learning in early childhood teacher training. *Australian Journal of Early Childhood* 18(3) 43 – 48.
- Domin, D. (1999). A review of laboratory instruction styles. *Journal of Chemical Education* 76(4) 543 – 547.
- Duch, B. J. (1995). What is problem-based learning? *About Teaching: A newsletter of the Center for Teaching Effectiveness*, 47. Retrieved October 7, 2005 from:
<http://www.udel.edu/pbl/cte/jan95-what.html>
- Duffy, T. M., and Bednar, A. K. (1991). Attempting to come to grips with alternative perspectives. *Educational Technology* 31(10) 12 – 15.
- Dyke, P., Jamrozik, K., and Plant, A. J. (2001). A randomized trial of a problem-based learning approach for teaching epidemiology. *Academic Medicine* 76(4) 373 – 379.
- Engel, J. (1991). Not just a method but a way of learning. In D. Boud and G. Feletti (Eds.) *The Challenge of Problem-Based Learning* (p. 21-31). London: Kogan Page.
- Erlendsson, J. (1991). *Student Motivation*. Retrieved June 30, 2005 from:
http://www.hi.is/~joner/eaps/wh_motia.htm
- Garrison, D. R., and Anderson, T. (2003). *E-Learning in the 21st Century: A framework for research and practice*. London, UK.: RoutledgeFalmer.
- Herreid, C. F. (2000). I never knew Joe Paterno. *Journal of College Science Teaching* 29(4), 158 – 161.
- Henderleiter, J., and D. L. Pringle, 1999. Effects of context-based laboratory experiments on attitudes of analytical chemistry students. *Journal of Chemical Education* 76: 100 – 106.
- Hilgard, E. R., and Bower, G. H. (1975). *Theories of Learning*. Englewood Cliffs, NJ.: Prentice Hall.
- Honebein, P. C., Duffy, T. M., and Fishman, B. J. (1993). Constructivism and the design of Learning Environments: Context and authentic activities for learning. In T. M. Duffy, J. Lowyck, D. H. Jonassen, and T. Welsh (Eds.) *Designing Environments for Constructive Learning*. New York, NY: NATO Scientific Affairs Division.
- Jensen, M., Guttschow, G., and Hill, M. (2002). Technophobia and teaching technology-rich freshman science courses. *Journal of College Science Teaching* 31(6) 360 – 363.
- Kant, I., (1974). *Logik* (translated). Indianapolis: Bobbs-Merrill (original work published 1800).
- Kanuka, H., and Anderson, T. (1999). Using Constructivism in Technology-mediated Learning: Constructing order out of the chaos in the literature. *Radical Pedagogy* 1(2). Retrieved September 16, 2005 from:
http://radicalpedagogy.icaap.org/content/issue1_2/02kanuka1_2.html

Problem-based Learning in an Online Course: A case study
Cheaney & Ingebritsen

- Klemm, W. R. (2002). FORUM for case study learning. *Journal of College Science Teaching* 32(6), 298 – 302.
- Margetson, D. (1994). Current educational reform and the significance of problem-based learning. *Studies in Higher Education* 19(1), 5 – 19.
- Maudsley, G. (1999). Do we all mean the same thing by “problem-based learning”? A review of the concepts and a formulation of the ground rules. *Academic Medicine* 74, 178 – 185.
- Michel, M. C., Bischoff, A., and Jakobs, K. H. (2002). Comparison of problem- and lecture-based pharmacology teaching. *Trends in Pharmacological Sciences* 23, 168 – 170.
- Mierson, S. (1998). A problem-based learning course in physiology for undergraduate and graduate basic science students. *Advances in Physiology Education* 275(supplement) S16 – S27.
- Molenda, M., (1991). A philosophical critique of the claims of “constructivism.” *Educational Technology* 31(10), 44 – 48.
- Morgan, A., (1983). Theoretical aspects of project based learning in higher education. *British Journal of Educational Technology* 14(1) 68 – 78.
- Mullins, G., 1994. The evaluation of teaching in a problem-based learning context. In S. E. Chen, R. Cowdroy, A. Kingsland, and M. Ostwald (Eds.), *Reflections on Problem Based Learning* (p. 105-124). Sydney: Australian Problem Based Learning Network.
- Navarra, J. G., Levin, J., and Navarra, J. G. Jr., (1993). An example of the use of meteorological concepts in the problem-based general-education experiences of undergraduates. *Bulletin of the American Meteorological Society* 74, 439 – 446.
- Oliver, R., and Herrington, J. (2000). Using situated learning as a design strategy for Web-based learning. In B. Abbey (Ed.) *Instructional and Cognitive Impacts of Web-based Education* (p. 178-191). Hershey, PA: Idea Group Publishing.
- Patel, V. L., Groen, G. J., and Norman, G. R. (1991). Effects of conventional and problem-based medical curricula on problem solving. *Academic Medicine* 66, 380 – 389.
- Peters, A. S., Greenberger-Rosovsky, R., Crowder, C., Block, S. D., and Moore, G. T. (2000). Long-term outcomes of the New Pathway Program at Harvard Medical School: A randomized controlled trial. *Academic Medicine* 75, 470-479.
- Russell, A. L., Creedy, D., and Davis, J. (1994). The use of contract learning in PBL. In S. E. Chen, R. Cowdroy, A. Kingsland, and M. Ostwald (Eds.) *Reflections on Problem Based Learning* (p. 57-72). Sydney: Australian Problem Based Learning Network.
- Russell, T. L. (2001). *The No Significant Difference Phenomenon* (5th ed.). Montgomery, AL.: International Distance Education Certification Center.

Problem-based Learning in an Online Course: A case study
Cheaney & Ingebritsen

- Ryan, G. L., and Quinn, C. N. (1994). Cognitive apprenticeship and problem based learning. In S. E. Chen, R. Cowdroy, A. Kingsland, and M. Ostwald (Eds.) *Reflections on Problem Based Learning* (p. 15-33). Sydney: Australian Problem Based Learning Network.
- Ryle, A. (1975). *Frames and Cages: The repertory grid approach to human understanding*. London: University of Sussex Press.
- Savery, J. R., and Duffy, T. M. (1995). Problem Based Learning: An instructional model and its constructivist framework. *Educational Technology* 35(5), 31 – 37.
- Schmidt, H. G. (1993). Foundations of Problem-based Learning: Some explanatory notes. *Medical Education* 27, 422 – 432.
- Shannon, S., and Brine, J. (1994). Consolidating professional skills and developing the confidence of graduating architects. In S. E. Chen, R. Cowdroy, A. Kingsland, and M. Ostwald (Eds.) *Reflections on Problem Based Learning* (p. 201-217). Sydney: Australian Problem Based Learning Network.
- Shunk, D. H. (2000). *Learning Theories: An educational perspective* (3rd ed.). Upper Saddle River, NJ.: Prentice-Hall.
- Spiro, R. J., Feltovich, P. J., Jacobsen, M. J., and Coulson, R. L. (1991). Cognitive Flexibility, Constructivism, and Hypertext: Random access instruction for advanced knowledge acquisition in ill-structured domains. In T. Duffy and D. Jonassen (Eds.) *Constructivism and the Technology of Instruction*. Hillsdale, NJ.: Lawrence Erlbaum Associates.
- Spiro, R. J., and Jehng, J. C. (1990). Cognitive Flexibility and Hypertext: Theory and technology for the nonlinear and multidimensional traversal of complex subject matter. In D. Nix and R. J. Spiro (Eds.) *Cognition, Education, and Multimedia: Exploring Ideas in High Technology*. Hillsdale, NJ.: Lawrence Erlbaum Associates.
- Steel, R. G. D., and Torrie, J. H. (1960). *Principles and Procedures of Statistics with Special Reference to the Biological Sciences*. New York, NY.: McGraw-Hill.
- Tolnai, S. (1991). Continuing medical education and career choice among graduates of problem-based and traditional curricula. *Medical Education* 25(5), 414 – 420.
- von Glaserfeld, E. (1989). Cognition, construction of knowledge and teaching. *Synthese* 80, 121 – 140.
- von Glaserfeld, E., and Smock, C. (1974). Introduction. In C. Smock and E. von Glaserfeld (Eds.) *Epistemology and Education: The Implications of Radical Constructivism for Knowledge Acquisition. Mathemagenic Activities Program – Follow Through*. Athens, GA.: University of Georgia.
- Wankat, P. C. and Oreovicz, F. S. (1991). *Teaching Engineering*. New York: McGraw-Hill.

Problem-based Learning in an Online Course: A case study
Cheaney & Ingebritsen

White, H. B. (1996). Dan tries Problem-based Learning: A case study. In L. Richlin (Ed.) *To Improve the Academy, Vol. 15* (p. 75-91). Stillwater, OK.: New Forums Press and the Professional and Organizational Network in Higher Education.

Willingham, D. T. (2004). Reframing the Mind. *Education Next* 4(3), 18 – 24.

Wright, J., Millar, S., Kosciuk, S., Penberthy, D., Williams, P., and Wampold, B. (1998). A novel strategy for assessing the effects of curriculum reform on student competence. *Journal of Chemical Education* 75, 986 – 992.



November – 2005

Remote Access to Instrumental Analysis for Distance Education in Science

Dietmar Kennepohl, Athabasca University – Canada’s Open University

Jit Baran, Northern Alberta Institute of Technology, Canada

Martin Connors, Athabasca University – Canada’s Open University

Kieron Quigley, Northern Alberta Institute of Technology, Canada

Ron Currie, Northern Alberta Institute of Technology, Canada

Abstract

Remote access to experiments offers distance educators another tool to integrate a strong laboratory component within a science course. Since virtually all modern chemical instrumental analysis in industry now use devices operated by a computer interface, remote control of instrumentation is not only relatively facile, it enhances students’ opportunity to learn the subject matter and be exposed to “real world” contents. Northern Alberta Institute of Technology (NAIT) and Athabasca University are developing teaching laboratories based on the control of analytical instruments in real-time via an Internet connection. Students perform real-time analysis using equipment, methods, and skills that are common to modern analytical laboratories (or sophisticated teaching laboratories). Students obtain real results using real substances to arrive at real conclusions, just as they would if they were in a physical laboratory with the equipment; this approach allows students to access to conduct instrumental science experiments, thus providing them with an advantageous route to upgrade their laboratory skills while learning at a distance.

Introduction

For most of us the term “remote control” conjures up images of kids playing with radio controlled model cars and airplanes or some sort of rampaging science fiction robot manipulated by the villain in a story. Yet remote control is well incorporated into our growing technological world. We have automatic car starters on our key chains, police bomb squads regularly make use of robots, un-manned reconnaissance drones are used by the military, and most of us use a remote control to change television channels.

The concept of using remote control in the sciences is not new either. Scientists often exploit the advantages of remote access when the experiment they wish to conduct is physically inaccessible by virtue of location or danger. For example, safety demands that all nuclear fission reactors are operated remotely and the location of the orbiting Hubble space telescope makes remote control a

necessity. One stunning high profile example of remote control is the landing of the NASA twin exploration rovers *Spirit* and *Opportunity* on Mars in January 2004. These rovers are now physically and chemically exploring that planet while being controlled from Earth.

A strong laboratory component is at the heart of many science courses. It is also one of the more challenging components to deliver effectively at a distance (Kennepohl and Last, 1997). There is no one correct solution or technology and often an assortment of methods are used in concert to overcome these challenges. The methodology and success of varying approaches to delivering science laboratories at Athabasca University has been discussed elsewhere in some detail (Holmberg and Bakshi, 1992; Kennepohl and Last, 2000; Connors, 2004). In each instance, however, the intent is to offer students a laboratory experience equivalent to, but not necessarily identical to, that they would encounter in a more traditional face-to-face setting.

With the availability of the World Wide Web, both campus and distance-based educators in disciplines like biology, chemistry, physics, and engineering, which traditionally have a strong laboratory component, have been exploring the integration of experiments into their face-to-face and online courses. In many instances, the online laboratory components are simulated and offer the “so-called” virtual laboratory experience (Kennepohl, 2001). A few groups, however, have directed their efforts towards allowing students remote access to real experiments. For example, an optical experiment at Stanford University in the United States is described under the Cyberlab project (Hesselink, Rizal, and Bjornson, 2000). There is also the *PEARL* project (**P**actical **E**xperimentation by **A**ccessible **R**emote **L**earning) which is a consortium of European Union (EU) institutions developing remote experiments in spectrometry, cell biology, manufacturing engineering, and electronic engineering (Cooper, et al., 2000). Another EU consortium called *Network for Education – Chemistry* uses mostly interactive simulations, but is also exploring online remote process control by way of a residence time distribution experiment (Zurn, Paasch, Thiele, and Salzer, 2003). Our own research has primarily focused on controlling sophisticated analytical instruments in chemistry (Baran, Currie, and Kennepohl, 2004).

Most modern analytical instruments are intimately controlled by computer, thus making access by remote control possible. Several others have already reported using the commercially available *LabVIEW* software system for controlling instrumentation and acquiring data in an in-class teaching environment (Drew, 1996; Gostowski, 1996; Haines, 1998; Spanoghe, Cocquyt, and Van der Meeren, 2001). In a recent pilot study, which allowed chemistry students to control analytical instruments in real-time, we demonstrated that a client-server application can be achieved from a remote location over the Internet, with an acceptable level of security, using *PC-Duo* software (Baran et al., 2004). Although the initial pilot study has shown the viability of this concept, the present work describes adapting this technology to a teaching environment that allows students both facile access to instrumental chemistry experiments and an advantageous route to upgrade their laboratory skills at a distance. Bernard and coworkers recently presented evidence through a comprehensive meta-analysis of empirical literature that distance education was generally comparable with classroom instruction on a number of variables including retention and learning outcomes (Bernard, Abrami, Lou, Borokhovski, Wade, Wozney, Wallet, Fiset, and Huang 2004). Building on the contention that classroom and distance delivery could be equivalent, we were interested in a comparison of a remote teaching laboratory environment with the face-to-face environment. Our intent was to create a remote laboratory experience that is comparable with traditional laboratories. We wanted to determine whether facilitating real laboratories at a distance through remote technologies could be achieved and demonstrated within the context of specific experiments. In addition to our main consideration of sophisticated

analytical instruments, we also briefly describe the remote control and monitoring of a simple physics experiment.

Technical Details of Remote Access System Used

A series of 15 different analytical instruments were interfaced to computers, which in turn were connected in a local area network (LAN) in a laboratory environment (see Figure 1). An Internet Security Accelerator Server (Reverse Publisher Server) was set-up to permit access to this LAN over a firewall using terminal emulation software. *PC-Duo* software was adopted for the terminal emulation to allow control of the desktop of a computer operating an instrument within that LAN. This arrangement was deployed so that the bulk of the software required to operate the instruments resides with the institution rather than on the remote workstation. The student or guest accessing any of the instruments requires only an Internet browser at their location.

Figure 1. Remote Access to Analytical Instruments

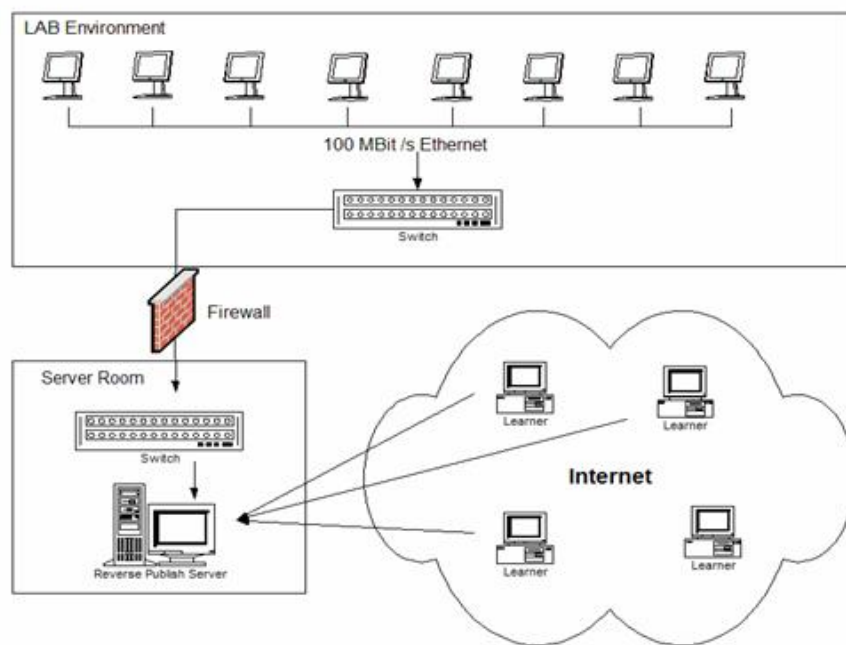

The following components were integrated into the website to facilitate access to performing a real time laboratory exercise and to provide a remote “screen” in the portal system, thus allowing students control of the analytical instrument: an Internet-based portal product, multimedia components, remote desktop control software, firewall security, self-contained webcams, streaming video server, NetSupport *PC-Duo*, TCP port assignment, scheduler, concurrent logons, and self-learning tutorials.

Virtual versus Remote Access

It is important here to differentiate between virtual and remote access. We define virtual access as interactive computer simulations of instrumentation and experiments. Virtual laboratories can prepare students for a real laboratory environment or conversely reinforce concepts from theory

or experiment. In contrast, remote access allows students and/or researchers to physically carry out real experiments over the Web. Training involving Internet access to instruments and computers monitoring an experiment is a real laboratory experience. This experience far surpasses that which might be had using a simulation or computer program, and directly prepares students to use equipment commonly found in industrial or research laboratories. Students perform real-time analysis using equipment, methods, and skills that are common to modern analytical laboratories (or sophisticated teaching laboratories). Students obtain real results using real substances and make real conclusions, just as they would if they were in the laboratory with the equipment.

Key Components of the Remote Lab Site

It is not enough for students to have the ability to remotely connect with, and physically control, an analytical instrument to carry out an experiment. The site should be sufficiently self-contained so that novices can learn the basic chemical principles, as well as how to operate the instrument in a remote environment. This project was designed to build a seamless pedagogical front-end for instrument access in order to facilitate the high level of student learning and skills-development necessary to carry out an experiment at a distance. Some of the components that are incorporated into the *Canadian Remote Sciences Laboratories* (CRSC) website, found at www.remotelab.ca, include:

- 1. *Public information*** describing the project, the researchers, and funding sources. This allows first-time visitors to get a brief glimpse of the site, the research being carried out, and to assure themselves of the credibility of the site and its developers.
- 2. *Password protection*** to limit access to the tutorials and, more importantly, the actual instruments. This has the logistical function of addressing system security and prohibiting unauthorized use or potential vandalism.
- 3. *FAQ and Help sections*** address common problems encountered by students. This is a proactive supply-side mediation approach designed to efficiently answer commonly anticipated questions.
- 4. *Connection to the instructor*** for further address problems. Initially this was done asynchronously by email, but a chat feature on the website now provides more direct communication. This is a demand-side mediation approach designed to address specialized and real-time questions and needs of students. It is also intended to establish moral support for individual students through provision of a “teaching presence” connection (Anderson, Rourke, Archer, and Garrison, 2001).
- 5. *Chemical principles tutorial*** to introduce students to the software, the instrument, and the particular experiment being undertaken. The purpose of the tutorial is to develop fundamental or remedial skills in the chemical principles, the instrumentation, and the online environment itself. General instrument tutorials consist of streaming videos that demonstrate use of instrumental software provided by the manufacturer to perform instrumental analysis. Interactive review exercises are also available to aid students in the recall of some of the key features of a particular aspect of the instrumental analysis software. Separate tutorials exist for particular experiments on a given instrument and may include downloadable text files.

Figure 2. Streaming video demonstrating the instrument within the tutorial section

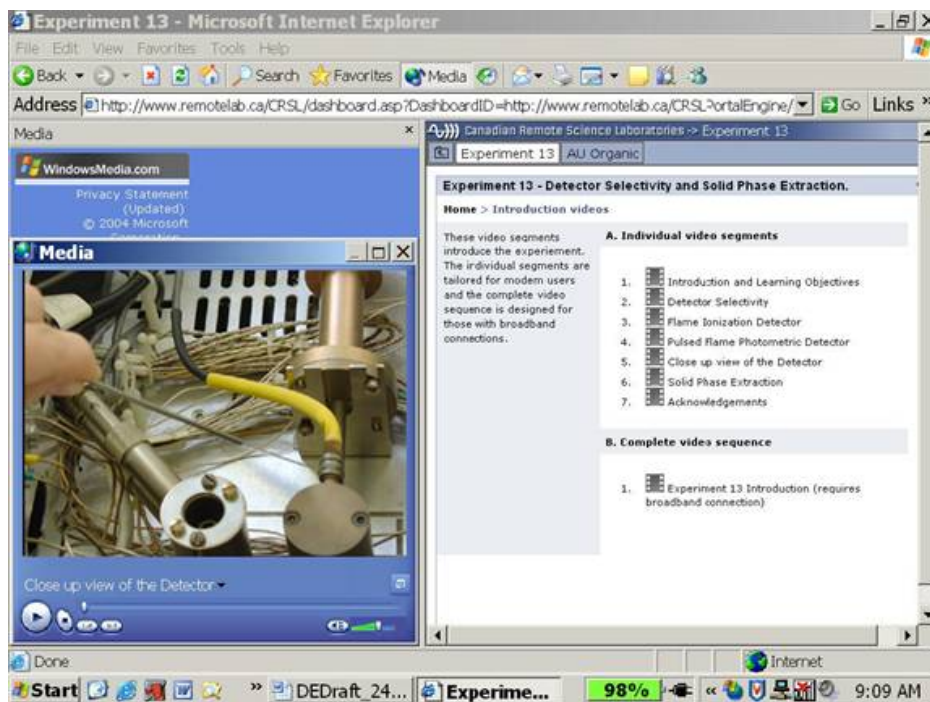

6. **Qualifier exercises** to establish a minimum skill level for students before moving onto actual instrument access. This provides scaffolding for students to help them master content and skills. It also limits exposing expensive instrumentation to complete novices, which may have the potential for frustration on all sides.

7. **Scheduler function** to help students and instructors assign unique and secure instrument time to qualified operators. This is a logistical function designed to insure effective use of these resources.

8. **Actual instrument access** to carry out experiments on real samples submitted earlier. This places students in a discovery or problem-based learning environment wherein they measure and collect real data. The intent is to reinforce upon students basic concepts and develop laboratory skills, while navigating potentially non-ideal results.

Figure 3. Actual instrument access of chromatography experiment in progress with web camera view (insert) in real-time

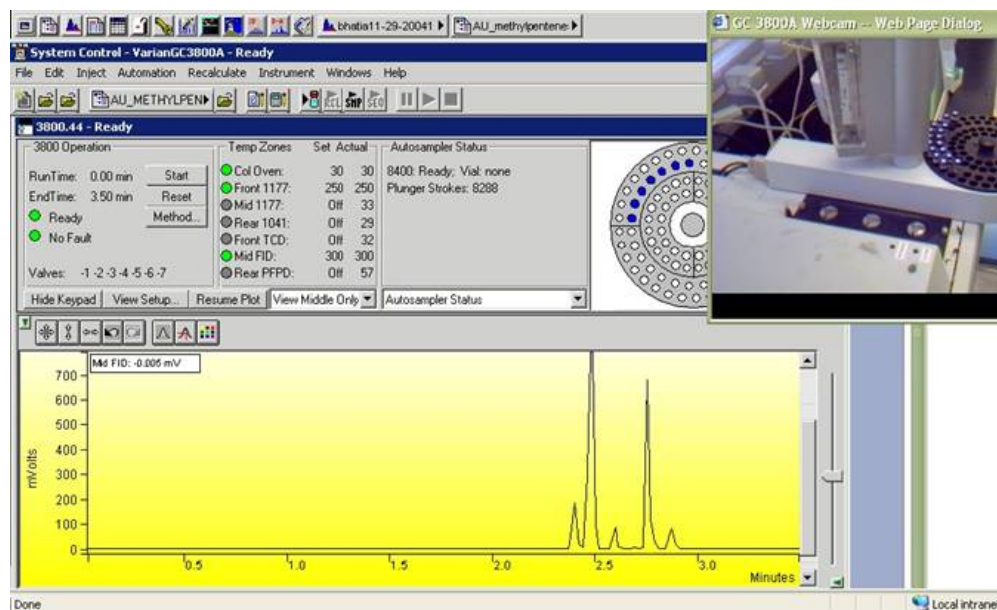

9. **Web camera** to allow real-time viewing of the instrument during the experiment. The purpose is to make the instrument real for the remote student – i.e., “seeing is believing.”

10. **Databases** obtained mostly commercially with the instrument manufacturer and used as a reference library to compare with actual data obtained. This resource allows students to practice contrasting their measurements with more standardized or ideal results.

11. **eLogbooks** allow students to make comments and house data collected from the instrument. These “eLogbooks” are typically submitted by students, either in whole or in part, for their laboratory report. The use of eLogbooks allow for the facile handling of large data sets collected, so students are not immersed in the details of preparing tables by hand, but instead focused on learning the actual experiment itself. It also provides students with a vehicle to develop their note taking skills, which is an important part of scientific experimentation.

12. **Supplementary resource materials** provided for each experiment guide learners to use additional information or useful links for further study. This is a gateway into related online literature rather than a comprehensive source. The purpose is as a resource for report preparation and to make students aware of the larger body of information available.

Method

The remote control environment for these chemistry experiments was new to both students and instructors. Indeed, many of the features incorporated were untested in the remote environment we created. Rather than construct rigorous measures to compare the remote and face-to-face environments in detail, we decided instead to examine student achievement and measure the attitude of individual students in the remote environment. Because we viewed this as a work in progress, this formative evaluation serves to provide initial feedback on an alternative laboratory delivery method, thus allowing us to use that information to direct future approaches.

Both chromatography and spectroscopy are important techniques widely used in both research and industry. Chromatography is a technique that allows chemists to separate a mixture of compounds by running it through a chromatographic column. Each component has a characteristic separation rate, which can be used to identify it and therefore the composition of the original mixture. Spectroscopy is another useful analytical technique used to identify a substance by the characteristic spectrum of light (e.g., visible, ultraviolet, infrared) absorbed or emitted. Our remote instrumentation was modified for specific experiments in chromatography and spectroscopy within the regular teaching laboratory. Typically students attend a supervised face-to-face laboratory session where they prepare calibration standards and sample solutions on site. Once solutions have been prepared the vials containing the standards and samples are placed in the autosampler or autoinjector. The samples are then analyzed by the student on site or remotely. The onscreen workstation environment is identical for the operator whether he or she is working down the hall, off campus, or right beside the instrument itself. A login and password are assigned to students who have successfully completed the online tutorial and qualifier exercises; this allows them access and physical control of the instrument at pre-booked time slots. A group of 34 students carried out three experiments in an analytical course that involved remote access. They were surveyed on their experience at the end of each experiment, and the laboratory course grades were compared with students who did the same experiments face-to-face, in person.

Varian and Agilent Chromatography Software ***(Experiment 1: Chromatography)***

During the first two weeks of the course, students worked through a series of tutorials designed to give them basic working knowledge of the software being used. Although called an experiment, no “wet chemistry” was carried out. Students were then surveyed on their experience.

Fourier Transform Infrared (FT-IR) Spectroscopy Methods ***(Experiment 12: Spectroscopy)***

In this experiment students used a Nicolet Avatar 320 FT-IR instrument and viewed a video tutorial on the components and function of the FT-IR to examine the effects of resolution and apodization functions on the quality of spectra; analyze a polymer using a horizontal attenuated total reflectance cell and observe the effects of scan number; perform a library search to identify the polymer; and perform quantitative analysis on ethyl acetate within a sample mixture following spectral subtraction during the laboratory component of this experiment. Before accessing the FT-IR remotely, students were required to examine an introductory tutorial that reviews the theoretical concepts behind the experiment and prepare the eLogbook by accessing the remotelab website. Students submitted their pre-lab eLogbook via email to their instructors before accessing the instrument; this precautionary step ensured solution preparation calculations and chemical safety aspects had been reviewed. Onsite time in the laboratory was required by students to prepare solutions and acquire spectra to be used when performing the experiments remotely. This required about one-half hour of onsite time before accessing the instrument. The time chosen by the students to perform this component of the experiment was flexible. After the lab was finished, students completed their eLogbook and submitted their report to their instructor via email. Students were then surveyed at the end of their course.

Detector Selectivity and Solid Phase Extraction (Experiment 13: Chromatography)

In this experiment students compared the sensitivity and selectivity of two detectors on a Varian 3800A Gas Chromatograph: the flame ionization detector (FID) and a pulsed flame photometric detector (PFPD). Students also developed a solid phase extraction (SPE) procedure for sample preparation. The wet chemistry, including the SPE procedure, was performed by students onsite in the laboratory. Samples were then placed in individual vials, which were then positioned on an autosampler of the Varian 3800A GC to be remotely accessed at a later time. Students were required to engage in a pre-lab exercise before the instrument was accessed. Once again, students were assigned to review an online text and/or audiovisual presentation using the remotelab website to examine the theoretical concepts for this experiment. Additionally, students had to prepare and submit their eLogbook via email prior to the experiment. An instrument .pdf file was a component of the website to enable instrument conditions to be documented within the eLogbook before entering the laboratory. Results and discussion were recorded by students in their eLogbook, which they submitted to their instructor by email. The chromatograms and reports once again had to be accessed from the laboratory printer. Students were then surveyed at the end of the course.

Survey Results

Varian and Agilent Chromatography Software (Experiment 1: Chromatography)

In this experiment 32 of the 34 students responded to the first survey, which was administered just prior to the laboratory examination two weeks into the term. All but four students reported using a highspeed connection (ADSL/ cable/ Ethernet) for their browser, and 31 of 32 students reported viewing the videos in the tutorial section. Students rated the quality of the tutorial videos on a five-point Likert scale. Students reported a high rate of satisfaction (4.3) on the size, clarity, sound, and smoothness of the videos. The students scored video clips slightly lower in the Understanding (4.0) and Appropriate Length (3.6) categories. This survey also had the students rate their preferred instructional format. The highest single method preferred by students was face-to-face or in-lab instruction (3.9); followed by online tutorials (3.5); and information given by text only (2.7). The choice of combining all three methods (4.3) was reported by students to be the most preferred instructional format, however.

Fourier Transform Infrared (FT-IR) Spectroscopy Methods (Experiment 12: Spectroscopy)

Only 15 of the 34 students responded to the survey. Although not necessary to operate the remote instrument, all but one student ($n = 15$) used high speed connections. Only nine students made use of the online tutorials, a much lower proportion than seen in Experiment 1. The rest presumably relied on written instructions that could be downloaded or on prior knowledge. Quality ratings reported by students using a five-point Likert scale were similar, but slightly higher, when compared with Experiment 1. That is, satisfaction with the size, clarity, sound, and smoothness of the videos (4.7); Understanding (4.1); and Appropriate Length (3.7). A summary of survey results of the tutorial videos is given in Table 1. It is interesting to note that the Appropriate Length scores did not correlate to the actual length of the video clips. That is, long

videos were not necessarily more boring. For example, the “Discussion of the Library Search” (1:47 min) scored 3.5, while “Experiment Setup Window Entries” (5:15 min) scored 4.3. This seems to indicate that students’ interest (and subsequent high/strong Length scores) could be maintained even though a video clip is longer. There were additional resource materials available on the website for student use; however, only one student made use of these materials. The ease of use of the eLogbook received an overall score of 4.7 by the students. There were some minor difficulties with the Solution Preparation and Example Calculations sections of the eLogbook for this experiment, but student comments indicate this might be more of a formatting problem.

An average rating of 2.8 was obtained for both ease of use of the instrument remotely versus onsite, as well as the overall rating of the remote access experience. There were comments about the technical aspects of the computer interface. Some students found the software to be slow, the screen display was not large enough for a few, and use of an instrument by more than one person at one time (students worked with partners) caused a little instrument control confusion. Two recurring comments offered by students about their experience in this experiment became apparent early on. First, students found the additional flexibility of doing tutorials, experiments, and searching databases from home to be valuable in this learning content. Second, students were constantly looking for in-person help.

Table 1. Selected Student Ratings (1 = *unacceptable* to 5 = *high quality*) of Online Tutorial Videos

Category	Experiment 1	Experiment 12	Experiment 13
Size, Clarity, and Sound	4.3	4.7	4.0
Understanding	4.0	4.1	4.5
Appropriate Length	3.6	3.7	4.0

Detector Selectivity and Solid Phase Extraction (Experiment 13: Chromatography)

Only 12 of the 34 students responded to this survey. Of those, 4 of the 12 students reported accessing the remote experiment using a modem connection, while the others reported using highspeed connections. Again, a larger proportion of students (11/12) viewed the videos in the tutorial portion of this experiment compared with Experiment 12. Quality ratings reported by students using a five-point Likert scale were significantly lower for videos. In this experiment, satisfaction with the size, clarity, sound, and smoothness of the videos (3.6 – 4.3) scored about a half point lower when compared to Experiment 1, which was conducted at the beginning of term. It also scored one full point lower than Experiment 12, even though the same format was used in all cases. Despite this, Understanding (4.5) and Length (4.0) obtained the highest scores. The eLogbook received an overall score of 4.8 by the students, which is almost identical to Experiment 12. This time the Solution Preparation and Example Calculations sections rated higher and were not seen as problem areas. Only two students reported using the additional resource materials available on the website.

Average ratings obtained for both ease of use of the instrument remotely versus onsite (3.3), as well as the overall rating of the remote access experience (3.2) were slightly up from the previous experiment (2.8). Again, similar comments on the technical aspects of the remote experience

were received including screen display size. Also, the larger themes of desired in-person help and the convenience of the flexibility offered by remote access were also brought up by this group of students.

Discussion

The main focus of the *Canadian Remote Sciences Laboratories* website has been the chemistry experiments that involve student control of sophisticated analytical instruments. We also developed one simple physics experiment for first-year physics students. This remote lab experiment is used by students to determine the acceleration of gravity by dropping a steel ball. This device allows g (gravitational constant) to be determined to within 1 percent. Details of the experiment set-up and its evaluation will be described elsewhere. One of the more important features of this experiment was the use of a *JVC web-cam*, which allowed students to see the experiment in progress in real time. It is the combined feedback of both measured data values and images of the apparatus in motion that provide a true lab environment for the remote operator.

Remote control can be applied to both simple experiments and complex instruments. It therefore becomes crucial for educators to select an environment that is most appropriate for their students. A ball drop experiment seems to work well for first-year physics students, while the handling of complex analytical instruments works well for senior chemistry students. In a recent study, however, we had general first-year chemistry students remotely access an Ultraviolet-Visible Spectrophotometer to measure sample concentrations, which yielded mixed results (Baran, et al. 2004). Students reported that learning the instrument interface – whether on site or remotely – was too much to ask for in a general first-year chemistry experiment, where only a handful of data points would be generated.

Nonetheless, the use of remote access offers distance educators in science another tool to provide a quality laboratory experience for their students. In our particular case in chemistry, remote control and the use of sophisticated analytical instruments are well-suited to each other. Since almost all current analytical instruments are already computer controlled, the ability to network them or set them up for remote access is relatively easy. In addition, exposure and practical experience with computer-controlled instruments – including remote access – is a valuable experience for students, as eventually they will be working with similar systems in industry. Other educators have also emphasized the importance of early introduction to modern instrumental methods at the undergraduate level in chemistry (Drew, 1996).

The mean laboratory course grade for students ($n = 33$) in the remote environment was 74.6 percent. The mean grades for two other cohorts ($n = 46$; $n = 47$) not using the remote connection (in different years of the same course) were 76.4 and 78.6 percent respectively. A t-test was performed and the two groups in years where there was no online component resulted in a P value ($\alpha = 0.05$) of 0.381. A comparison of the online cohort (74.6%) with each of the other non-online cohorts (76.4 and 78.6%) resulted in P values ($\alpha = 0.05$) of 0.491 and 0.117, respectively. There are no significant differences in performance between groups of students carrying out analytical experiments on site versus remotely. So in terms of measuring by class grades, the learning achieved appears to be equivalent. From the students' perspective there has been a genuine appreciation for both the accessibility and the flexibility of remote access in the chemistry experiments we described. This was pronounced in our student surveys. As one student put it: "*The single best aspect of the remote experience is that I could do the majority of the lab at home in my pajamas.*" Another student noted: "*It can be accessed from anywhere, and simplifies the chromatography without pages and pages of chromatograms.*" That positive perspective also

seems to be shared by students elsewhere involved with similar remote access studies reported in the literature. Students do not wish to be tied down in time or place to set laboratory exercise. The ability to work at one's own pace and at one's desired time, coupled with the ability to repeat experiments, is appealing. Remote access also has a potential advantage for students with disabilities. Not only does it address potential issues of safety, equipment handling, and physical access to the laboratory, the computer interface makes possible the use of suitable assistive technologies that might not be available *in situ*.

From an institution's perspective, remote experiments mean better use and sharing of equipment and less need to provide supervised laboratory sessions. It also opens the possibility of sharing expensive equipment for both teaching and research. From the instructors' perspective there have also been advantages. Online access means laboratory manuals can be readily upgraded, team teaching can be facilitated, and student work can be directly verified. In addition, the multiple user access to the website permits an instructor to observe students using instruments in the laboratory via remote access and to intervene using a chat tool when help is requested.

This brings us to the main criticism raised by students. Despite reporting a preference for a combination of instructional formats (text-based, online, and face to face), students also pronounced their desire to have in-person help when using the remote control access. Although students had access to tutorials, self tests, email, and the chat tool, they apparently preferred to speak face-to-face with a live instructor. This finding is also supported by the drop in participation rate in a group of 34 students from 32 in Experiment 1; to 15 in Experiment 12; and finally to 12 in Experiment 13. Why did this occur? In the first survey students prepared for the laboratory exam in the second week of the term where they needed to demonstrate proficiency in the use of the Varian and Agilent software. Instructors were not available to be consulted during that time. During the rest of the term laboratory instructors were available, however. Thus, there was no need for students to review the introductory tutorials related to the lab since the instructors were physically present to assist them understand the various features of the laboratory during the lab period.

Although students' desire for in-person help is apparent, the question we ask now is whether that need is real? Our experience teaching students in traditional supervised chemistry laboratories has been that there is an overwhelming tendency to ask the instructor questions first, rather than read the information in the laboratory manual. Could this be happening here too with the remote access laboratories? Are students seeking the path of least resistance? Or is it possible that the information presented on the website is not easily retrievable by students when they are trouble shooting. Perhaps there needs to be some sort of online help function designed to assist students retrieve the information they need? Another scenario to be considered is that students are simply looking for some level of human connection and reassurance.

Finally, we should make a brief comment on problem solving. Since these remote laboratories exist in the physical world with real experiments on real samples, there is also the possibility of operational problems, errors, and non-ideal results. In moderation, we view this as a beneficial for the student. Ironically, creators of some simulated experiments spend a lot of effort incorporating errors into their programs to make them more real and place the learner into a problem-solving environment. Our real-life experiments seem to do this automatically and we should see this as an opportunity to encourage learning.

We would like to summarize our experience and the discussion of our observations above as lessons learned.

- **Seeing is believing – using a camera to see the experiment is important to the student.** (Although not investigated in our studies, this might eventually be extended to sound cues also.)
- **It is important to match the experiment and student for the appropriate level of experimental and remote environment complexity.** (Computer manipulations must be reasonable for the eventual data obtained to seem worthwhile.)
- **Students like the additional access and flexibility of the experiments.** Faculty like making better use of existing instrumentation by employing them during non-business hours.
- **Students reported great desire for in person instructor contact.** However, is this needed or just wanted?
- **Problems can be a good thing.** Unexpected technical and experimental results in small quantities can lead to valuable learning opportunities.

Future Directions

This pilot study finds student performance to be equivalent for the remote laboratory experience and for face-to-face experiments. However, such scenarios should be explored in more detail so that the learning specific to the laboratory is more rigorously tested. With remote experiments incorporated into regular laboratory work, both the learning and the cost effectiveness of the approach will be easier to measure.

Our intent is to offer instruction and access to online experiments in a seamless package, one which is as self-contained as possible. As educators, we also want students to struggle and think about what they are doing, rather than being spoon-fed instant answers. On the other hand, any instruction should not be so inaccessible that students become lost or frustrated. In future modifications of the remote lab portal, we would like to specifically address the help function for the learner, while maintaining a self-contained online package for both teaching and instrument access. We also feel that it would be informative to pilot some of these experiments with groups of students that are well removed from the physical location of the analytical instruments and the instructors. This would effectively require students to communicate and learn on their own at a distance, rather than dropping by an instructor's office down the hall for in-person help. Another feature we would like to incorporate is a trouble-shooting flowchart, or decision tree, or autonomous agent, to assist student learning online. Such a feature would be in addition to FAQ pages that assist students with commonly encountered technical problems or misconceptions. We would also like to develop a video connection to facilitate more intimate communication between instructors and students while maintaining a remote environment. We have already discovered in both the physics and chemistry experiments that a visual image is powerful. It is possible for students to control an instrument using only the on-screen display offered by the instrument manufacturer. If, however, they see the instrument moving in real time as they are controlling it, the experience is enhanced. They feel it is real.

We have implemented and tested a complete remote laboratory environment for chemistry and tried out one physics online experiment. There are numerous advantages to remote experimentation and it is a natural adjunct to courses in which the other components are also offered by distance education. Since at least in upper level chemistry, remote control techniques

for instruments closely parallel those used in an onsite laboratory itself, this is a natural subject area for further implementation of the remote environment we have developed. With good feedback and ancillary materials we suggest that distance education implementation of laboratories through remote access techniques can only gain in importance and contribute in a significant way to science education.

Acknowledgements

We appreciate Athabasca University project students Edna Cabalo, Jason Ponto, and Christy Tkatchuk who contributed to several key areas of the project development. We also thank Randy Troppman (NAIT) for assistance with areas of application development and web site design.

We are grateful for financial support of our home institutions NAIT and Athabasca University and funding through the Office of Learning Technology, a department of Human Resources Development Canada.

References

- Anderson, T., Rourke, L., Archer, W., and Garrison, R. (2001). Assessing teaching presence in computer conferencing transcripts. *Journal of the Asynchronous Learning Network*, 5(2) Retrieved September 17, 2005, from: <http://www.aln.org/alnweb/journal/jaln-vol5issue2v2.htm>
- Baran, J., Currie, R., and Kennepohl, D. (2004). Remote Instrumentation for the Teaching Laboratory. *Journal of Chemical Education*, 81(12), 1814 – 1816.
- Bernard, R. M., Abrami, P.C., Lou, Y., Borokhovski, E., Wade, A., Wozney, L., et al. (2004). How Does Distance Education Compare With Classroom Instruction? A Meta-Analysis of the Empirical Literature. *Review of Educational Research*, 74(3), 379 – 439.
- Cooper, M. (2000). *PEARL: Effective learning through remote experiments*. A collection of papers by various authors. Retrieved September 26, 2005 from: <http://iet.open.ac.uk/pearl/index.htm>
- Connors, M. (2004). A Decade of Success in Physics Distance Education at Athabasca University. *Physics in Canada*, 60(1), 49 – 54.
- Drew, S. M. (1996). Integration of National Instruments' LabVIEW Software into the Chemistry Curriculum. *Journal of Chemical Education*, 73(12), 1107 – 1111.
- Gostowski, R. (1996). Teaching Analytical Instrument Design with LabVIEW. *Journal of Chemical Education*, 73(12), 1103 – 1106.
- Haines, R. S. (1998). Teaching Computer Concepts to Undergraduate Chemists. *Journal of Chemical Education*, 75(6), 785 – 787.
- Hesselink, L., Rizal, D., and Bjornson, E. (2000). *CyberLab: Remote access to laboratories through the world-wide-web*. Retrieved September 26, 2005 from: <http://www.discoverlab.com/References/043.pdf>

Holmberg, R. G., and Bakshi, T. S. (1992). Postmortem on distance education course: Successes and failures. *American Journal of Distance Education*, 6(1) 27 – 39.

Kennepohl, D., and Last, A. (1997). Science at a Distance. *Journal of College Science Teaching*, 27(1), 35 – 38.

Kennepohl, D., and Last, A. (2000). Teaching Chemistry at Canada's Open University. *Distance Education*, 21(1), 183 – 197.

Kennepohl, D. (2001). Using Computer Simulations to Supplement Teaching Laboratories in Chemistry for Distance Delivery,. *Journal of Distance Education*., 16(2), 58 – 65.

Spanoghe, P., Cocquyt, J., and Van der Meeren, P. (2001). A Low-Cost Dynamic Surface Tension Meter with a LabVIEW Interface and Its Usefulness in Understanding Foam Formation. *Journal of Chemical Education*, 78(3), 338 – 342.

Zurn, A., Paasch, S., Thiele, S., and Salzer, R. (2003). Linked Curriculum Chemistry: Different from a virtual university, *CHIMIA*, 57(3), 105 – 115.



November – 2005

Teachers' Invisible Presence in Net-based Distance Education

Agneta Hult, Ethel Dahlgren, David Hamilton and Tor Söderström
Pedagogiska institutionen, Umeå Universitet
Sweden

Abstract

Conferencing – or dialogue – has always been a core activity in liberal adult education. More recently, attempts have been made to transfer such conversations online in the form of computer-mediated conferencing. This transfer has raised a range of pedagogical questions, most notably “Can established practices be continued? Or must new forms of participation and group management be established? This paper addresses these questions. It is based on two sources: (1) 3,700 online postings from a variety of Net-based adult education courses in Sweden; and (2) interviews with participants and course-leaders. It comprises a discussion of online conversational activity and, in particular, the absent presence and pedagogic orientation of teachers who steer learners towards explicit and implicit course goals. In other words, it is a reminder that adult education is not a free-floating form of self instruction but, rather, operates within boundaries created and managed by other human beings.

Keywords: conferencing; dialogue; online participation; absent presence; adult education; auto-didacticism

When the school child solves a problem at home the teacher is not standing near him. This help is invisibly present.

Lev Vygotsky, 1987, p. 216, abridged

Learning Conversations in Adult Education

Much of the literature on computer-mediated conferencing relates to instructional learning environments. In these contexts –the British Open University is a paradigm example – learners are led or steered towards identified educational goals. In short, such learning is fostered through a complementary practice-teaching. A seminal text in this respect is Gilly Salmon's 2000 *E-Moderating: The key to teaching and learning online*.

Some authors, like Salmon, have noted that the words ‘teacher’ and ‘teaching’ are unfashionable in the learning society. Other words, like ‘moderator’ and ‘moderating’ are preferred, symbolising the indirect influence of the course tutor, leader, or facilitator. Another example illustrative of the unease over earlier educational labels is Dianne Laurillard's preference for ‘conversation’ rather than ‘dialogue’ in her 2002 *Rethinking University Teaching*. This preference arises from doubts about the merit of so-called Socratic teaching when viewed from

the values of 21st century pedagogy. For instance, Socratic teaching has been characterised as a form of ‘bullying’ (Griffiths 2001, p. 34), on the grounds that it is more of an interrogation than a conversation. Laurillard seems aware of these doubts and refers to the ‘myth’ of Socratic teaching (2002, p. 74). Her preference for higher education, therefore, has a more positive tone: attention to ‘conversational framework[s]’ for teaching. Indeed, she adopts the latter perspective not so much in the light of classical Greek precedents but, rather, in the light of twentieth century research on language and communication.

The word dialogue is also problematic for etymological reasons. Confusions arise because the Greek suffix ‘di’ means ‘through’ rather than ‘two’ – which is why dissect means ‘cut through’ and diaphanous means ‘see-through.’ The word conversation does not carry this ambiguity. Conversation does not necessarily require two participants: It can be a reflexive activity (as when we talk to ourselves) or can be a group activity with more than two participants. Conversing and conversation also corresponds to the English terms, albeit of older usage, confer and conference.

We raise these distinctions because they have a particular educational resonance in Sweden. For about a century, conversation (*samtal* in Swedish) has occupied a particular space in Nordic adult education. It emerged from German notions of *Bildung*, the idea that, somehow, human beings can steer – or mediate – their own development (i.e., self-instruction or auto-didactics). Thus, ideas about conversational regimes of teaching and learning entered educational practice; and they were celebrated in the role that study circles have played, and continue to play, in the field of popular liberal education (*folkbildning* in Swedish).

Thus, Swedish liberal adult education has always offered forms of personal and collective self-education for citizens denied other pathways of social enlightenment. Popular educational forms emerged at the beginning of the twentieth century. They included study associations, libraries, study-circles, and folk high schools where participants could read books, listen to lectures, and discuss current affairs. By the beginning of the 1920s such educational forms began to receive state support. Liberal adult education was expected to promote a specific sense of citizenship which, in a formulation used in the 1920s, ‘rested on the acquisition of knowledge of noble sentiments and refinements.’ Through the exercise of such educational freedoms and rights, citizens would become well-informed and, thereby, contribute to social progress. In this respect, the Swedish Prime Minister Olof Palme (1927 – 1986) is remembered in adult education for his claim that Swedish democracy had been built on a foundation of study circles.

Thus, conversation has been both a means and an end in Swedish adult education. Yet, in practice, little attention has been given to how such conversations have been conducted. How, for example, are they initiated, steered, and closed? And what, in short, can be said about the leaders, tutors, facilitators or moderators who, in Vygotski’s words, are ‘invisibly present’ or, in Northedge’s words ‘excursion organisers’ (Northedge, 2002, p. 253) that foster ‘meaning making’? (Salmon, 2000, p. 39) Thus, this paper focuses on an aspect of liberal adult education – the role of the teacher – that is relatively invisible and, in Swedish liberal education at least, relatively unacknowledged.

Indeed, this problem is not restricted to Sweden. Earlier work reported in Hamilton, Dahlgren, Hult, Roos, and Söderström (2004), suggests that within the European Community (Common Market), little attention is given to the difference between behaviourist and constructivist theories of learning (cf. Sfard, 1998). The stance taken in this paper, then, is constructivist – that conversation is learning in the making. A conversation comprises utterances – in the sense embraced by Mikhail Bakhtin (1981) – that, to varying degrees, are a response to earlier utterances. In other words, every mono-logic utterance can also be regarded as an element in a dialogue. “The nature of discourse,” as Burbeles and Bruce describe the same phenomenon, “is

that the language we encounter already has a history. The words that we speak have been spoken by others before us” (2001, p. 1111). Any conversation, that is, draws on heteroglossia (Bakhtin’s neologism) – pools of different ideas whose elements, when exchanged, foster learning. According to Bakhtin, every utterance has a double significance. It is an expression of a 'unitary [common] language' used to conduct the conversation and, at the same time, it builds on the 'social and historical' differences embedded in the heteroglossia (1981, p. 272). Burbeles and Bruce make the same point in a different way:

A dialogue is not simply a momentary engagement between two or more people; it is a discursive relation situated against the background of previous relations involving them and the relation of what they are speaking today to the history of those words spoken before them. These background conditions are also not simply matters of choice, and they impinge on the dialogic relation in ways that may shape or limit the possibilities of communication and understanding (2001, p. 1111).

Bakhtin's contemporary, Yuri Lotman, offered a similar analysis of conversation. He described conversations as multi-authored texts rather than as multi-voiced heteroglossia (see Bakhtin, 1994, for further discussion of Lotman). In a cultural system, Lotman suggests, texts “fulfill at least two basic functions: to convey meanings adequately, and to generate new meanings.” The first function, Lotman continued, “is fulfilled best when the codes of the speaker and the listener most completely coincide and, consequently, when the text has the maximum degree of univocality” (1988, p. 34). The generation of new meanings occurs when there are differences between the speaker and the listener. Texts used in educational exchanges cease:

. . . to be a passive link in conveying some constant information between input (sender) and output (receiver). Whereas in the first [univocal] case a difference between the message at the input and that at the output of an information circuit can occur only as a result of a defect in the communication channel and is to be attributed to the technical imperfections of this system, in the second [dialogic] case such a difference is the very essence of a text's function as a 'thinking device'. What from the first standpoint is a defect, from the second is a norm, and vice versa. Of course, the mechanism of a text must be organised differently in the second case (Lotman, 1988, pp. 36 – 37).

From this theoretical and pedagogical standpoint, online adult education is not the delivery of texts but, rather, the creation and insertion of ‘thinking devices’ into conversation.

Online Adult Education

During the 1990s, the Swedish state endorsed the development of online forms of liberal adult education. Yet, over the same period, adult education also underwent significant changes. Most notably, the boundaries between liberal adult education and award-bearing adult education were blurred. This arose from the political demand that that adult education should serve citizens who, for different reasons, had missed educational opportunities available earlier in their lives. Accordingly, Swedish adult education has acquired a hybrid form. It is conversational because it respects the traditions of Swedish *folkbildning*; and it is pragmatic because it responds to the credentialing demands increasingly attached to life-long learning. Indeed, this convergence has also been carried over into online *folkbildning*. Nevertheless, conversational aspects are still given prominence and priority. Online practices are animated by means of ‘forum’ or ‘conference’ software (typically the commercial application known as FirstClass®). Courses are arranged

around two activities: progression through a series of task- and content-oriented 'conferences,' and 'coffee-breaks' in online 'cafes' where participants are encouraged to congregate or 'hang out.'

This paper arises from a programme of research into the online initiative in Swedish liberal adult education. It is based on three sources of data. First, an analysis of approximately 3,700 postings from eight different courses which were award-bearing (e.g., upper secondary school mathematics) as well as non award-bearing (e.g., courses on religion, creative writing). The postings were transcribed, coded, and analysed according, among other things, to their date, time, and content. Second, tape-recorded face-to-face or telephone interviews with six teachers and 18 students (one very active, one medium active, and one drop-out) from six of the courses were conducted approximately one year after the conclusion of each course. These interviews focused on the teachers' and students' experiences of learning and communicating in online courses and study-circles. For this article we have concentrated on teacher and student views of teachers' role orientations in online courses. Finally, our data included postings made by adult education tutors who participated in a separate course which had 'online teaching' as its topic. The courses ranged in duration from 10 to 17 weeks.

In this paper, we concentrate on what the data revealed about conversational practices in online education and, in particular, about the activities of the course leaders and the perceptions that students and teachers had of the general course activities. Moreover, this work was conducted within ethical guidelines – about the personal integrity of online data – that are accepted in Sweden.

The purpose of our research was not to establish Swedish norms, nor set forth an international league table. Neither the fluid state of the field, nor our sampling procedures provide such affordances. Instead, our intention has been to identify and clarify teaching 'salience' that have emerged in online adult education in Sweden. In a wider sense, however, our analysis is also a response to the question: 'Whatever happened to teaching in the learning society?'

The argument of this paper falls into four sections. First, we identify teacher visibility by reference to our posting data. Second, we discuss the different forms that such presence occupies in the minds of the teachers and students. Third, we revisit a recurrent problem in open education – the tension between student and teacher presence. Finally, we discuss the implications of our findings for the discussion and analysis of online education – much of which is directed toward adults.

Conversational Activity

Postings during the first month varied across the courses, from an average of 5 to 20.4 postings per student. As has been found elsewhere (e.g., Hawkrige, as quoted in Salmon, 2000, p. 82; Romiszowski and Mason, 1996) posting activity varied among students and decreased during the life of a course. During the last month of the courses for instance, the average number of postings per student ranged between 1.7 and 14.8.

Posting frequencies, however, yields only limited information. If possible, more penetrating questions should also be asked. How, for instance, do adult education teachers participate in such conversations? Do they initiate activity? Do they re-orientate activity? And if necessary, how do they restrict or terminate unwanted activities? In fact a striking pattern of teachers and student activity soon emerged from our data: teacher and student postings co-related over time (see Figure 1).

Figure 1. Percentage of student and teacher activity by week

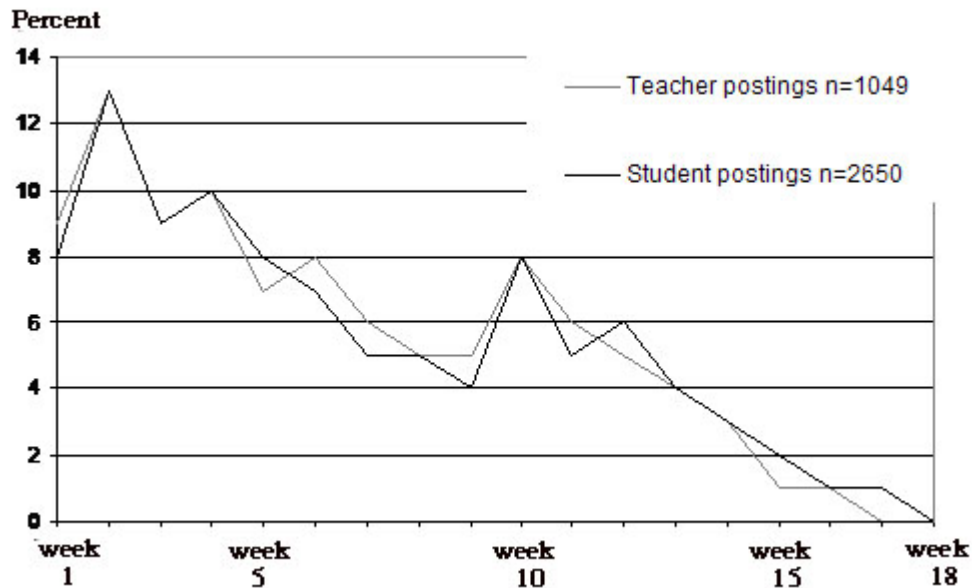

By themselves, these figures do not justify the claim that teacher postings steered the activity. Nevertheless, other data from our sample suggested this was, in fact, the case. Despite variation in the courses – some courses were more conversational than others – the posting data support the claim that the teachers adopted an initiating role. They displayed, for instance:

- 1. Greater activity:** eight teachers made almost 1/3 of all the postings compared to the 111 students who posted the remaining two thirds.
- 2. Greater influence on topic:** Thirty percent of the teachers' subject matter postings initiated a new line of discussion or a new topic, whereas only 13 percent of the equivalent postings by students took this form.
- 3. Faster response times:** Seventy-seven percent of teacher responses were made within 24 hours compared to 52 percent of student responses, suggesting that teachers were more reactive in their initiations.

Another confirmatory source was the interview data. When asked about their views, all students felt that teachers played a central role in supporting Net-based learning. Indeed, some of them suggested that moderation in online settings of adult education is more important than in face-to-face settings. Nevertheless, there was considerable variation over what teachers and students felt about this central role.

Orientations to Teaching

Most of the students, and also the teachers, referred to the settings – or learning environments – that teachers occupy on the Net; while a few of the students took a different stance, feeling that the teacher's importance lies in the ways that they validate and legitimate students' efforts. Together, teachers and students spoke about teaching as comprising at least three orientations. Adult education teachers took up an activity orientation to stimulate learning; they adopted a

conference orientation to sustain learning; and they took up a validation orientation to corroborate learning.

Activity Orientation

In this perspective, teachers gave students tasks that activated them and, thereby, fostered their understanding of subject matter. When they have got their assignment, "learning is what you do yourself," one student stated. Teachers also offered students tips about articles, books and Internet sites. In turn, students felt that their learning widened and deepened as they searched for information to complete the allocated tasks. Students felt activated by the teachers' interventions:

I think someone has to be responsible, kind of holding everything together. So she [the group leader] was the spider in the Web. Then, of course, she [also] set all the assignments.

Conference Orientation

Some students spoke about being activated by stimulating tasks that led them to engage with the Web and libraries, with one of them adding 'seeking by your self is a pre-condition for learning.' Active searching also meant that students came into contact with information which extended their learning beyond the task itself.

Students also remembered conversational teaching that fostered discussion and interaction. They felt they learned from the views expressed by other students and by their teacher. The teacher linked the completion of set tasks to contact with other students. Such teaching, the students felt, not only promoted subject understanding but also projected the utility of group conversations. Although one student stated that he began by reading [offline] he added that, thereafter, such material:

. . . must be discussed and talked over with some other students to see their view of the subject . . . We have to discuss in order to develop a broader picture of the issue.

This view of *folkbildning* was also reflected in the interviews with teachers. All defended, in varying degrees, the relevance of dialogue and collective learning. One teacher, for instance, illustrated this viewpoint by comparing two types of task. One, which he rarely set, required students to find a correct answer in the text. His preferred option, however, was a task where participants take a stand on issues raised in the courses. The second option, he accepted, was 'a bit more difficult and challenging' because students required access to 'more information.' Learning arises, he suggested, through the Hegelian cycle of 'thesis, anti-thesis, and synthesis.' Arguments challenge each other, rendering the dialogue process intrinsically 'instructive.'

None of the teachers, however, was entirely satisfied with their dialogic or conference practice. Levels of engagement, dialogue, and initiative-taking were not as high as they had hoped. In response, they tried to promote conversation by encouraging students to react to each other's postings, by organising tasks where cooperation and interaction was needed, or by introducing new aspects and questions when discussion faltered.

When the course activity dries up I try with a new intervention. Sometimes I send a personalised private mail which usually does the trick.

Further, teachers reported that they also tried to act as models of good behaviour by giving swift replies to student postings and by making their own postings appropriate yet concise.

On the other hand, some teachers with greater experience of online education reported that they took a more laid-back position. They reduced their postings in the hope of increasing student responses. The lowest level of teacher posting was 13 percent of the total postings for the specific course; while the highest level (50 percent) came, in fact, from the teacher who claimed retrospectively to have cut down his postings to foster increased participation by students.

In contrast to the teachers most of the student group were satisfied with the course conversations. One student who reported extensive online course experience commented that, apart from a math course, general discussion was typical and that on her current philosophy course there was an 'enormous amount' of conversation.

A few students, however, expressed disappointed in the interviews. The argumentation and group-work they had expected had come to nothing: 'It can be fun when you are two people and you can bandy ideas about and explore different angles on the subject. But it didn't happen.' They felt that sharing different aspects of the subject matter with the teacher and fellow students raised fresh questions. It made them reach beyond the book, evoking learning and thinking along new pathways. Even if they thought that well-chosen tasks were the most effective way of fostering dialogue, they also expected the course leader to participate fully, developing new themes if student postings declined, and remaining alert to student proposals that might enhance the interchange of ideas and knowledge.

Validation Orientation

Many students emphasised the importance of teaching that corroborated or validated their learning. In some cases, this arose with teaching that expanded the students' outlook (see Engeström's discussion of learning by expanding, 1987).

Students studying creative writing, for instance, emphasised the importance of their teacher's observations and reflections. They felt such contributions highlighted aspects of their work that they could develop further:

You get views from others on what you have done and you can think about it . . .
The course is organized so that everybody should comment and help each other.
But still it is the teacher who has more experience. At least I listen a lot to the teacher.

In some cases, teaching merely comprised affirmation rather than expansion. Teachers affirmed students' understanding. Teachers' comments kept them on-course, through correcting their misunderstandings and misinterpretations. As one student explained:

If you don't get to know what you do is right or wrong, you don't learn anything .
. . . When things slip up and become muddled, they [teachers] can sort them out.
Thus, they have to be present (sic) and see what happens.

None of the teachers, however, spontaneously offered this view as their primary role or orientation. Nevertheless, when asked whether they had any correspondence with students through private mailboxes rather than 'conferences' and 'cafes,' some of them said that they occasionally responded privately to correct misinterpretations. Finally, their corroboration

sometimes took the course-wide form of helping students to feel legitimate members of the course, despite their geographical dispersal. Such teaching enhanced students' sense of presence or belonging and, accordingly, augmented their capacity to deal with the course:

I think that they [teachers] play a very important part. [They are someone who] can be positive and give every student the attention they need to feel important, by saying 'this is jolly good.' Or as my teacher wrote: 'you really keep me busy, if only every student were like you.' Maybe she writes that to everyone, I don't know, but to me it means that I feel a bit special.

Planning for Democracy?

As noted earlier, extensive discussions have taken place about fostering student activity and dialogue in online education. In Sweden, this task retains an ideological role since liberal adult education is regarded as a source of democratic empowerment. Students are expected to play a part in this process, for example in planning their courses and conducting such courses through the medium of discussion and deliberation. While aspiring towards the ultimate promotion of democracy, such courses are also expected to manifest democratic conference practices.

This task raises many questions about teaching, highlighting the difference, for example, between instructionist and constructionist paradigms for learning (Wilensky, 1991). Would a too well-planned course be instructionist, thus constraining student influence and the pursuit of democracy? In their postings, teachers in this study felt that there was no necessary contradiction – that well-planned courses could, indeed, strengthen student influence. Nevertheless, busy distance education students, according to the teachers, often appreciate instructionist courses with clearly stated activities and tasks, even if the students are left with limited opportunities to 'construct their own relationships with the objects of knowledge' (Wilensky, 1991, p. 202).

Tight course organisation may arise from the teachers' view of their own responsibilities, even duties. They may over compensate in their online courses because they find it difficult to apply their earlier experience of face-to-face adult education. In their postings, they suggested it was more difficult to be constructionist; that is, to work in a context where the learner is 'consciously engaged in constructing a public entity' (Papert, 1991, p. 1). It is not easy, they suggested, to have a 'feel' for what is appropriate in online circumstances, to manage students at different levels, to find appropriate leading questions, to be spontaneous and, not least, to explain – without sounding patronising – that these online studies are the students' own responsibility.

Overall, the data from this research suggest that both students and their adult education tutors feel a strong personal and professional need for a teacher's 'presence' in online education. Whether the teacher's presence in online learning is any different from the presence of adult education leaders in the past is beyond the scope of this paper. Nevertheless, the issue of teacher presence – and its form and enactment in teaching – remains important in both distant and adult education. Likewise, issues surround the reconciliation of teacher presence with student presence. Active presence may be disguised with other labels (e.g., by referring to discourses of learning rather than teaching) but the general issue of how knowledge and knowing are mediated from person to person, and from generation to generation, remains central to all educational practice. By analogy with the ether problem in the history of science, what, in fact, fills the space between human beings when they dialogue and learn from each other?

Discussion

The stimulus for writing this paper was the observed synchronicity of teacher and learner activity in a sample of online courses in Swedish *folkbildning*. This observation led to further investigation of teaching in online education and, in turn, to a mapping of teacher orientations using data collected from course postings and interviews.

Overall, this paper is a contribution to the fields of open education and liberal adult education. Learning conversations, dialogic inquiry, and flexible learning have always had a place in liberal education. Yet, as indicated throughout this paper, the fusion of liberal education and online learning is more than the application of new terms to old practices. Rather, as the fusion metaphor implies, online teaching and learning have their own integrity.

This paper commenced with an examination of the role of teachers in the organisation of Swedish online learning. A central idea in liberal education is that such groups should be self-steering. Both the postings and the interviews, however, highlight the teacher's impact on the fostering of online student learning. Teachers and some of the students felt that the teacher's central role was to establish or preside over (Salmon, 2000, p. 3) a conversation or dialogue; while most of the remaining students indicated that teachers' foremost duty was to animate the student to seek new information and facts.

Teacher's invisible presence is exemplified in taking a stand-by role and/ or being reluctant to intervene. 'The [teachers'] silence should be deafening,' one teacher recommended. Although most of the teachers agreed that well-planned courses do not inhibit course dialogue, the fact that in their own online course deliberations they set aside time to discuss this issue may reflect ambivalence in their stance. The question of when and how teachers should intervene remains impossible to resolve, except in practice.

In our analysis we recognised three different aspects of teaching, all of them significant in the conduct of constructionist online liberal education. In turn, our exploration of the teacher's role in open learning environments leads to a second conclusion – that the promotion of learning in an open environment requires an animating or steering presence. Such teaching, however, is not a process of instruction. And for this reason the word teacher may no longer be appropriate. In English, the word tutor is commonly used in adult education, because it has connotations of 'supervision' and 'guardianship' as well as 'instruction' (see Oxford English Dictionary). More recently, Salmon has suggested 'e-moderating,' but even moderation carries instructionist connotations – to exercise a controlling influence over; to regulate, restrain, control, rule (OED) – that may not be appropriate to all forms of liberal education. In the context of mainland Europe, the word pedagogue may be appropriate since, etymologically, pedagogue denotes someone engaged in 'drawing out.'

All of these labels, however, are bedeviled by the issue raised at the outset of this paper – the failure of language or, more accurately, the English language, to capture the relationship between teaching and learning and between teachers and learners. In part this difficulty has historical and cultural roots. It arose in the eighteenth century Enlightenment, as notions of self-formation (*Bildung* in German) came to prominence and spread through Europe and the Americas; and it re-entered Anglo American thought in the 1950s, with the rise of cognitivism and, later, constructivism (see, for instance, Glasersfeld, 1995; Roos and Hamilton, 2005). The net result of these innovations was a transformation in concepts of learning and teaching. Adult education began to be activated by the idea that learning may be represented as self-teaching without the (visible) presence of others.

Intellectual development, however, can be an intra- as well as an inter-personal phenomenon. That is, learning may not come directly from teachers but rather from their absent or invisible presence. Online pedagogues, therefore, can be present in different ways. They may be present in person, participating in learning conversations. They may constitute an absent presence that, nonetheless, is embodied in the learning resources directed towards students (e.g., the selected readings or activities). Or pedagogues may exist merely as inner voices, inherited from the language of others, that (invisibly) steer the desires, self-regulation, and self-direction of learners. Indeed, this last pedagogic position 'auto-didacticism,' has always been central to the post-Enlightenment ideals of liberal adult education.

Conclusion

All educational practice is purposive and value-driven. Whether or not a teacher is physically or virtually present, educational practices are goal-directed. In the process, human beings are socialised, acculturated, formed, or lead out into new realms of knowledge and new ways of knowing. Indeed, such purposive – or reflexive – drawing out is a defining feature of educational practice. The main ethical question, in both off- and online learning, is who does the drawing out? Is it an external agent (a teacher)? Is it an internal agent (e.g., student's own motivation or desire)? Or is it a disembodied agent – the invisible hand, for instance, that shaped the Website? In myriad ways, these invisible hands structure online learning and its environment. Their presence, we believe, deserves the due attention of adult educators.

Acknowledgements

This paper arises from a project, Liberal Adult Education at a distance – a discussion milieu for learning (2001 – 2004), funded by the Swedish Council for Adult Education (*Folkbildningsrådet*), with the assistance of the LearnIT initiative of the Swedish Knowledge and Competence Foundation (KK – Stiftelsen).

The Project director can be reached via email at: ethel.dahlgren@pedag.umu.se. The project website is <http://alfa.ped.umu.se/projekt/folkbildning/>.

References

- Bakhtin, M. (1981). *The Dialogic Imagination*. Transcribed by C. Emerson and M. Holquist. Austin, TX.: University of Texas Press.
- Bakhtin, M. (1994). The Problem of the Text in Linguistics, Philology and the Human Sciences: An experiment in philosophical analysis. In V. W. McGee (Ed.) *Speech Genres and Other Late Essays* (pp. 103-131). Austin, TX.: University of Texas Press.
- Burbeles, N., and Bruce, B. C. (2001). Theory and research on teaching as dialogue. In V. Richardson (Ed.) *Handbook of Research on Teaching, 4th Ed.* (pp. 1102 – 1121). Washington, DC.: American Educational Research Association.
- Engeström, Y. (1987). *Learning by Expanding*. Helsinki: Orienta-konsultit.
- Glaserfeld, E. V. (1995). *Radical Constructivism: A way of knowing and learning*. London: Falmer Press.

- Griffiths, M. (2001). Social Justice for Education: What kind of theory is needed. *The School Field*, 12(1/2), 25 – 41.
- Hamilton, D., Dahlgren, E., Hult, A., Roos, B., and Söderström, T. (2004). When Performance is the Product: Problems in the analysis of online distance education. *British Educational Research Journal*, 30(6), 841 – 854.
- Laurillard, D. (2002). *Rethinking University Teaching: A conversational framework for the effective use of educational technologies*. London: RoutledgeFalmer.
- Lotman, Y. (1988). Text within a text. *Soviet Psychology*, 26(3), 32 – 51.
- Northedge, A. (2002). Organizing Excursions into Specialist Discourse Communities: A sociocultural account of university teaching. In G. Wells and G. Claxton (Eds.) *Learning for Life in the 21st Century: Sociocultural perspectives on the future of education* (pp. 252-264). Oxford: Blackwell.
- Papert, S. (1991). Situating constructionism. In I. Harel and S. Papert (Eds.) *Constructionism* (pp. 1-11). Norwood, NJ.: Ablex.
- Romiszowski, J., and Mason, R. (1996). Computer mediated communication. In D.H. Jonasson (Ed.) *Handbook of Research for Educational Communications and Technology*. New York: Macmillan.
- Roos, B., and Hamilton, D. (2005). Formative Assessment: a cyberNetic viewpoint. *Assessment in Education*, 12(1), 7 – 20.
- Salmon, G. (2000). *E-Moderating: The key to teaching and learning online*. London: Kogan Page.
- Sfard, A. (1998). On two metaphors for learning and the dangers of choosing just one. *Educational Researcher*, 27(2), 4 – 13.
- Vygotsky, L. S. (1987). *The Collected Works of L. S. Vygotsky: The problems of General Psychology*. New York: Plenum Press.
- Wilensky, U. (1991). Abstract meditations on the concrete and concrete implications for mathematics education. In I. Harel and S. Papert (Eds.) *Constructionism* (pp. 193-203). Norwood, NJ.



November – 2005

The Online Learning Environment: Creating a space for Mauritian women learners

Sushita Gokool-Ramdoe
Tertiary Education Commission, Mauritius

Abstract

This paper examines how online distance education acts to democratize access to, and suit the ontologies of, Mauritian women who seek to empower themselves for development. Data from semi-structured interviews of 30 middle class couples are presented in this paper. Interviews and analyses are premised on a feminist perspective and conducted within the social relations analysis framework. The objective of this research was to understand what types of supportive environments (social spaces) enable Mauritian women to engage in educational endeavours that promote their personal potentials and creativities which, in turn, advance democracy for all citizens of Mauritius. Husbands were also interviewed to provide ground for analysis and to decrease bias, which can be generated by women-only data. 1) *Marriage/ family* and 2) *occupation*, represent the ‘social spaces’ selected for this study. Discretion, degree of learner control, and the outreach capacity inherent in distance learning makes the online modality a natural choice to democratize women’s access to education. Based on interviewees’ experiences and perceptions, this study concludes that online learning can enhance and democratize women’s access to education for personal development – but only if the power relationships in the two ‘social spaces’ are well understood and well negotiated by these women. The findings in this paper shed light on the importance of understanding ‘learner spaces’ when establishing and setting-up open learning organisations.

Introduction

This paper analyzes the extent to which online distance learning works to democratize access to education for women learners in Mauritius; it also underlines the importance of providing a supportive environment to sustain women learners throughout their educational endeavours. Investigated are the interpersonal relationships of women learners in two ‘social spaces:’ (1) *family/ marriage* and (2) *occupation*. Explored are interpersonal relationships that can provide support – or become obstacles – toward women’s attainment of education. Also presented are strategies (i.e., as based on evidence gathered that reveal the hidden obstacles faced by women learners) that should ideally be woven into the developmental plan of any future open learning organisation in Mauritius.

Purpose

The purpose of this research is to determine how two social spaces, 1) *family/ marriage* and 2) *occupation* enable or impede women’s access and participation in educational opportunities via online distance learning. In short, the aim of this research is to uncover the degree to which these

‘social spaces’ can impede or empower women; it does so by exploring the interrelationship between distance education, occupation, and personal development. Put simply, the goal of the author is to advance the process of democratizing access for women learners in Mauritius, and does so by discovering via semi-structured interviews ‘what social situations’ impede or support women learners. The findings from this study support the call for course design strategies that address the specificities of women as distance learners in Mauritius; the findings also contribute to the literature on the field of women and distance education, specifically by providing a voice to women learners living in a developing country.

For this paper, ‘democratizing access’ means enlarging and enhancing possibilities of women learners to register and participate in an educational program; that is, examining how online education can be designed to suit the ontologies of Mauritian women to empower them for development. ‘Democratizing access’ is a functional definition that can be found in the UNESCO definition of ‘democracy,’ which stipulates that democracy is a dynamic state that offers a ‘space’ for individual voices. This ‘space’ encourages peace rather than conflict (UNESCO, 2001, p.25). The state of ‘continuing peace’ is an important concept within this conceptual framework; moreover, ‘continuing peace’ helps us to rethink the concept of ‘development’ as being premised on the notion of ‘human dignity’ as a central supportive element (UNESCO, 2001, p.25). In line with this re-conceptualization of ‘development,’ it is necessary to promote the development of ‘human creativities’ that aim to eliminate individual frustration. Indeed, from this conceptualization, ‘frustration’ is a major source of conflict, and thus a threat to democracy. As part of lifelong learning, ‘personal development’ is seen to be achievable through educational endeavours that are aimed at various levels of interventions and phases, and that are delivered through different modalities. Thus the link between education, personal development, national development, and democracy is well established. However, without placing emphasis on building viable ‘social spaces’ that provide access to education, it is impossible to realize the type of development necessary to foster ‘human dignity’ and nurture ‘human creativity.’ Because distance education offers tremendous access, particularly to marginal or oppressed groups seeking to negotiate and overcome impeding power relationships, the online educational modality may also be seen within the context of democracy.

Online Distance Education and Mauritian Learners

Rumble argues that Internet-based education “would meet the pressure from students for convenience-education by delivering programs into their homes” (Rumble, 2001, p. 5). In Mauritius, state-sponsored provision of online distance education is not yet existent, however. The good news is that this situation is starting to change. As of 2003, just over 40 percent of Mauritians reported owning personal computers (Week-end, 2003). In addition, several incentives are in place for sustainable provision of online distance education: the Development Bank of Mauritius is now offering low-interest loans to those individuals seeking to purchase a personal computer; Mauritius Telecom now provides affordable broadband packages; a growing number of (free of cost) computer courses are available to larger cross sections of Mauritius’ population; and finally, the Government of Mauritius is seeking to make e-learning more widely available, particularly through the creation of a new open learning organisation.

This study is premised on several assumptions. First, it is premised on the assumption that online education offers women wider access to more varied combinations of education. This study is also premised on the assumption that women must balance multiple ‘social roles’ as adult learners. It is from these dual assumptions – ‘social roles’ versus ‘student roles’ – that the interaction between online distance education and Mauritian women learners is examined.

Self-directed learning (Brockett and Hiemstra, 1991; Chang, 2003; Garrison, 2003) and constructive learning experiences that contribute to critical thinking in terms of learning to learn, (Moore and Kearsley, 1996), result in paradigm shifts which, in turn, act to catalyze personal development. In this study, the purpose is to understand how meaningfully online distance education can advance the 'democratization' of access for potential women learners in Mauritius.

This paper comprises three sections: 1) literature review; 2) overview of the research method and research process; and 3) a summary of the research findings, with particular emphasis paid to the possible application of the research findings aimed to guide the policies of a newly announced open learning organisation in Mauritius (Government of Mauritius, Budget Speech, 2004).

Part I: Literature Review

The Issue of Women's Access to Education

For the past two decades, particularly since the *Jomtien Conference on Education for All* (1990), the subject of educational access (especially women-related) has gained increased attention on the problems in terms access to education. Indeed, the subject of educational access has been gaining increased attention, ranging from the classical-liberal economic approach of the World Bank, to the human rights approach of agencies as the United Nations Development Program (UNDP) and the United Nations Children Fund (UNICEF). Many reasons can explain exactly why women in particular lack of access to education. In lesser developed parts of the world, like the sub-Saharan Africa for example, insufficient infrastructure, transport facilities, distance to schools, security problems, religious and cultural beliefs, economic constraints, and armed conflicts, are all major factors that impede women's (and others') access to education. Conversely, in the developed world, research indicates that impeding factors are subtly integrated in variables such as sexist curricula, sexist bias in classes, lower self-esteem of girls, and teacher's lower expectations (Stanworth, 1981).

It is within this context that distance education has often been seen as a potential solution to help advance the lot of women. May (1994), for example, argues that it is important to consider the feminist ramifications of distance education in order to enhance the understanding of women. This view is echoed by Kramarae (2003) and Henri (1989), and particular attention has been paid to women's socio-cultural and economic environments by the scholars Kirkup and von Prümmer (1990). The fact that more than a decade separates Kirkup and von Prümmer's views (1990) from Kramarae's (2003) indicates, however, that this topic is still in need of thorough investigation and remains extremely relevant to contemporary scholars researching the field of distance education and feminism.

Indeed, it was the paucity of research on middle-class women that spurred the researcher's interest to explore the reality faced by women learners in her native country, Mauritius. According to the literature, one's class position reflects his or her market situation (Haralambos, 1984). For example, the middle class women who participated in this study were all in a position to potentially better their life. Yet as Liddle and Joshi (1986) point out "the vast majority of educated middle-class women are still confined to domestic activities" (p. 55), which, for some women, can be truly oppressive. This means that 'social terms' pertaining to the nature and ownership of 'housework' for example, need to be redefined and re-negotiated. This study attempts to uncover the extent in which middle-class Mauritian women were redefining such 'terms' to make which their overall environment/ social spaces more enabling.

Part II: Research Framework

Standpoint Feminism

The feminist perspective, which has informed the basis for this study, is a “lens through which to view the process of inquiry and its social, historical, and political context” (Fonow and Cook, 1991, p.1-2). Among the various feminist research frameworks available – and despite the difficulty it may cause for over generalisation – this author opted for ‘*standpoint feminism*’ to form the basis of this research study. Some feminists (Harding, 1987; Hartsock, 1990; Ramazanoglu, 1993) advocate *standpoint feminism* as the best approach to investigate and understand women’s lived reality. From this perspective, women researchers are bound to produce knowledge about women that is “more complete and less distorted than [does a] man’s experience” (Harding, 1987, p.95). Moreover, while *standpoint feminism* accepts the basic premise of scientific endeavour, its knowledge is derived from a committed feminist exploration of women’s oppression (Fonow and Cook, 1991). The *standpoint feminism* perspective acknowledges the researcher’s bias, and requires that researcher explain the analytic process of her research (Harding, 1987; Hartsock, 1990; Ramazanoglu, 1993). However, standpoint feminism presents a threatened external validity. While there is no doubt about the internal validity of the data generated, critics of standpoint feminism could argue that the external validity of this perspective could be threatened because of the avowed subjective nature of its investigations and the inherent difficulty in replicating such studies.

Social Relations Analysis Framework

The researcher used the *standpoint feminism* perspective grounded within the ‘*social relations analysis framework*.’ The *social relations analysis framework* seeks to understand the social processes that sustain unequal power distributions. “Making power relationships the focus of analysis highlights the differences among women, and draws attention to factors other than gender through which groups have access to resources such as communities” (Heward and Bunwaree, 1999, p. 3). This framework helps to unveil the precise terms under which women and men cooperate, and examine the specific institutions such as marriage and markets, that structure such cooperation.

The Spaces Under Study: *marriage/ family and occupation*

Two social spaces were analyzed in this study: 1) *marriage/ family* and 2) *occupation*, and both were found to be ‘social spaces’ rife with power struggles. May (1994), for instance, argues that while cultural sensitivities must be considered, historical patriarchal structures also need to be thoroughly questioned and modified accordingly.

Marriage/ Family

Because they were the most private spaces in which married women operated, for the purpose of this study the opinions and viewpoints of both husbands and wives were sought, and *family/ marriage* as discrete institutions were merged together.

Heward and Bunwaree (1999) argue that marriage and cohabitation bind many women into unequal power relationships with men. According to these scholars, inequality is not intrinsic to relations between men and women, but is linked to wider social and economic structures. It is claimed that the institution of marriage itself holds significant influence on the welfare of women

and the status of men (Heward and Bunwaree, 1999). O'Connell (1994) explored the contradictions for women that are inherent in the family; she argues that while for many women 'family' is a place of security and support, it may also be an instrument of oppression, subordination, and brutality. Thus, it becomes necessary for researchers to ascertain the extent to which the husband, in particular, and the wider kinship in general, are supportive of women.

Occupation

Occupation represents the most public sphere wherein women construct meaningful experiences and relationships. In addition to advancing their material circumstances, employment can hold transformative potentials for women in terms of advancing and enhancing their self-worth and social potential. Heward and Bunwaree (1999) for instance, argue that women's access to education has improved the status of women within the family, in that education has acted to reduced family size, and it has expanded women's economic roles. This study, therefore, seeks to determine whether the relationship between distance education and occupation is similarly reinforcing; whether occupation can provide an 'empowering space' wherein women have both the time and facilities to study; and whether women acquire the skills they need for upward social mobility. Indeed, Bullock (1994, p. 89) recognized that women require a range of vocational, entrepreneurial, and managerial skills to positively transform their professional situation. In concurring with Heward and Bunwaree (1999), Bullock also concludes that the relationship between education, employment, and empowerment remains inherently complex.

Distance Education and Women

Education can enable women to discover, explore, and expand upon their hidden potential(s). Unless women have control over resources, however, education cannot be a guarantor of capitalizing on one's potentials. While education may not better women's general condition, it does place them at a decisive fulcrum which allows them to make more informed choices for personal development. The specific relationship between distance education and women is murky, however. While women stand as adult learners in their own right, the fact that they are 'women' gives them a specificity that must be thoroughly examined on its own terms. May (1994) for example, asserts that although women generally praise distance education, they also unanimously agree that "it isn't for everyone" and that it is a significantly different experience for female learners than male learners (May, 1994, p. 1). This reinforces the need to study women in terms of patriarchal-defined parameters.

Most distance learners are adults between the ages of 25 and 50 (Moore and Kearsley, 1986). Moreover, the attrition rate among these adult distance learners is a matter of concern, which has resulted in calls for research that aims to "to understand what causes some students to withdraw, in the hope of being able to improve their completion rates" (Moore and Kearsley, 1986, p. 153). Such research has been undertaken. Kemp (2002) for example, argues that personal characteristics such as motivation, self-efficacy, personality, attitude, and maturation combined with life circumstances and transitions, are predictors of attrition. The degree to which women are affected by such predictors can determine their successful completion of any distance learning course. May's (1994) findings, however, suggest that the actual control women exercise over their study schedules appears to be over-stated in the literature. Nonetheless, the women in May's study also claimed that access to, and use of, communication technologies for educational purposes (despite their imperfections) allowed them to juggle home-study with their busy schedules. She concluded, however, that further research remains warranted to improve women's distance study experiences (May, 1994).

On the other hand, Kemp (2002) research shows that students' work and/ or occupational obligations were found to impede the successful completion of their studies. In short, Kemp determined that personal 'life events' were not found to be a causative factor in learner persistence in general, but instead one's inability to strike a workable balance between *marriage family/ occupation* found to be strongly negative factor leading to student attrition. Kramarae (2003) furthers this line of research by stressing importance of ensuring that "past sexist practices, which have been a problem on most campuses, are not perpetuated online" (p. 261) – an issue that arguably remains both timely and valid over a decade later.

Online distance learning offers opportunities for collaborative learning, while at the same time enables learners to study at a time and place convenient to them. The Web allows for asynchronous (and increasingly synchronous) interpersonal communication, and facilitates learning between instructors and students, and collaboration among learners using email, bulletin boards, and online discussion forums. Web-based learning, however, should be meaningful, contextualised, and purposeful (Brown, 1997) for it to make a difference. The difference being that a fundamental distinction must be made between *opening access to education for greater numbers of students* and *opening access that fosters and enables 'human development.'* Indeed, opined here is that while there is merit in widening access to education, there maybe little real benefit in increasing the numbers of enrolees without a concomitant increase in viable employment opportunities. Hence, the need to exercise caution in developing distance education programs and establishing open learning organisations, versus what opportunities are really/ socially available to graduates.

The Research Context

The Mauritian population consists of 65 percent Indo Mauritians; 30 percent Afro-Mauritians; three percent Sino-Mauritians; and two percent Franco-Mauritians (Parsuramen, 1994). Supported by a research grant from the Mauritius Research Council, this study is based on qualitative research data gathered from 30 middle class couples of Indo Mauritian background. It was convenience sampling that dictated this selection. The nature of the research and the type of investigation involved made it difficult to include participants from other backgrounds because of their lack of willingness to reveal personal details.

Mauritius gained Independence from British rule in March 1968. And while primary schooling has been free in Mauritius since 1976, regardless of gender, secondary education has also been free. Therefore, because education in Mauritius is free it could be logically assumed that an increasing number of females should have benefited from the apparent educational opportunities available at the primary, secondary, and tertiary levels. Moreover, it could logically be assumed that access to free education should also have translated into women's increased participation in various skilled and professional occupations throughout Mauritius. Theoretically, expansion in the occupational economic structure should be reflected in educated women as part of the labour force. In reality, however, the number of females who reached tertiary education is considerably lower than that of males, especially considering that more young females than young males entered secondary education in Mauritius.

The figures in Table 1, derived from data produced by the Tertiary Education Commission Mauritius, shows that in 2003 female enrolment at public school secondary level in Mauritius stood at 51.9 percent compared to male enrolment of 48.09 percent. This data can be compared to tertiary level enrolment, which reveals that female entrants to the University of Mauritius drops to only 46 percent compared to 53.47 percent for males (TEC, 2003), a pattern of disparity that has persisted for the last 20 years. Gender-based data for students studying abroad or with private

educational institutions in Mauritius is not yet available and thus prevents a more complete picture from emerging at this time.

Table 1. Total Enrolment Rates by Gender and Level in Thousands for Year 2003

	Secondary Level (%)	Tertiary Level (University of Mauritius only)
Males	49.946	3.072
Females	53.901	2.673

During the course of this research study, steps were taken to identify the barriers Mauritian women typically face in their journey towards educational attainment. Based the findings of women's 'lived circumstances,' the use of online distance education as a delivery modality was analysed and found to be justified for this target group of learners. Thus, it is assumed here that strategies of inclusiveness for women learners in Mauritius tertiary educational system would contribute towards the democratic tradition of the country.

Research Methods

The type of information gathered from potential women learners in Mauritius covered the following broad areas, and eventually provided the guidelines for the formulation of the research questions:

1. How did the current education level of the subjects determine their awareness of the importance of personal development and related opportunities?
2. How did the subjects define 'personal development' and did they relate it to national development?
3. Given their familial responsibilities and professional commitments, how did subjects view online distance education as a means for personal development?
4. Is the '*marriage/family* sphere' an 'enabling space' for personal development? And what is the role of online distance education in that space?
5. Is the professional environment an 'enabling space' for personal development? And what is the role of online distance education in that space?
6. Did online distance education have a democratizing influence on access, as we tend to believe?

Thirty married couples ($n = 30$) comprised of working Indo Mauritian women and their husbands were interviewed to provide answers to the above. The questions posed to the husbands pertained mostly to their awareness of 'personal development' and the importance they attributed to this concept, as well as their contribution towards 'personal development.' To determine the research methods that would best answer these questions, the author used a method that springs from feminist theory.

The preferred method for this research study was the semi-structured interview. This approach allowed the researcher flexibility to allow respondents to ask questions if they felt they needed

clarification. The questions were "tailored to fit the respondents' knowledge, degree of involvement and status" (Guba and Lincoln, 1983, p.186).

Sampling

This study was based on convenience sampling. The majority of respondents were personal acquaintances of the researcher. Willingness to cooperate for this research was proportional to the researcher's closeness to the individuals, especially male spouses. This group was selected because of their financial and infrastructural ability to engage in online learning. The researcher had originally hoped to interview 100 couples, but ended up with only 30 couples.

To provide a more complete picture of how women lived and benefited from within their respective 'social spaces,' their husbands were also interviewed. This approach to data collection aimed to minimise the polarization between men and women, a situation that tends to happen inadvertently in feminist studies. Along with providing a firmer ground for analysis, this approach thus decreased the bias that may be generated by women-only data (Harding, 1987). It is believed that this would improve the internal validity of data finally obtained. Table 2 provides the breakdown of interviewees by age-group.

Table 2. Interviewees by Age-group

Age Group	Number of Women	Women Respondents (%)
20-30 years old	16	53.3
30-40 years old	9	30
40-50 years old	2	10
50-60 years old	2	6.7

The majority of women interviewees ($n = 16$) were from the 20-30 age group, while only two ($n = 2$) were from the 40-50 age group, and two ($n = 2$) from the 50-60 age groups. When interviewed, the husbands did not always volunteer personal information (i.e., age) so it was impossible to capture their age-groups in this study. Despite being more aware of possibilities and opportunities open to them, many of the younger women reported to having less space for decision-taking and action in their households, which were often watched over by their mothers-in-law. On the other hand, the older women reported that old age had shaken the stronghold of their mothers-in-law. This gave the older women in the study more 'space to breathe,' but they were sadly aware that a lot of time had gone by and there were many things in their lives that they would simply not have the chance to experience.

Class distinction in Mauritius should be mentioned at this point to provide contextual background for this study. Class distinction in Mauritius is inherently complex due to the interplay of ownership of property, level of income, and to some extent, ethnic variables. In the pre-Independence era, which was dominated by slavery (slaves from Africa and Madagascar) and indentured labour (labourers from India and China), the notion of class based on wealth, especially in terms of property, was concentrated in the hands of the French and British colonials. That concentrated wealth was eroded, however, when indentured Indian labourers were given marginal land to cultivate in lieu of salary (thus becoming wealthy property-owners); and indentured Chinese labourers were given opportunity to become traders (thus forming a wealthy business community). In the post-Independence era, much of the above status was retained with the only difference being a newly emerging middle-class comprised of franchised slaves and labourers (especially the educated), who started earning an income. To focus this study, class distinctions will only comprise level of income derived from employment based within the Indo-

Mauritian community. For ease of discussion, the researcher has not taken into consideration any other form of wealth.

Only eight of the Indo Mauritian women interviewed were from the lower-middle and 12 from the middle classes. Two from the upper-middle class were interviewed engaged in an online distance learning pursuit. All women were registered in graduate or under-graduate distance education programs. At the time of this study, all wives and husbands were engaged in full-time employment.

The Research Process

Underlying this research process was an awareness of power relationships – that is the researcher was aware of her power to activate and influence the research process; thus, like a mastermind, the researcher calculated for ways to elicit responses from some of her research subjects, specifically the reluctant husbands. The researcher achieved this by acknowledging husbands' worries, placating their egos, while at the same time empathising with the women.

The researcher met with all the wives and, in some instances, the couples in their own homes. When faced with reluctant husbands, however, the researcher found herself confronted with the necessity of devising a strategy to extract information. Empowered by the literature from feminist studies that describe the use of non-conventional data collection methods (Chant and Mc Ilwaine, 1998), the researcher resorted to an alternative tactic to gather the much needed data – she asked the wives of the reluctant husbands to interview their husbands themselves. Thus the researcher coached these wives to give their husband's a brief description of the research study. The purpose of this description was to solicit their husbands' participation. Of the 30 husbands interviewed, the researcher personally interviewed only eight. Data from the other 12 were gathered by the wives on her behalf. Ten husbands declined participation and informed the researcher that they did not want to disclose information/ details about their private spheres. In the face of this anticipated obstacle to data collection, it is opined that the husbands' interviews conducted by the wives still constitute an important source of information. Albeit imperfect, based on the results and quality of the data collected, the data can be used to inform future research.

Limitations

While this research study gained its strength from the documentation of various experiences, its major limitations were the lack of ethnic representation of the research population; the reluctance of some husband participants; and the un-anticipated method used to extract participation from some male subjects. In other words, without further research designed to validate this study's findings, readers are cautioned on the generalisability of the data collected and any inferences drawn. Despite this, however, enough information was gathered to formulate a coherent conclusion to this study.

Part III: Research Findings and Possible Applications

The strategy used was designed to enable women learners to participate more effectively in their 'social spaces.' Understanding women's roles and power structures is important in developing distance learning courses and programs of study. Based on the research findings, the analysis offered here is based on a feminist perspective. Indeed, researchers cannot eschew the business of studying from real life, nor can they ignore the power relationships that characterise spaces where

real life is enacted. Power relationships must therefore be thoroughly examined, understood, and inherent power relationships recognized and redressed. To help redress the current imbalance between female and male learners, a feminist approach should permeate any policy informing an open learning organisation in Mauritius.

Understanding Marriage/ Family and Occupation

From the data gathered, marriage and occupation for the middle-class women interviewed seemed to offer enough 'space' to foster personal development via participation in online distance educational activities. All women interviewed indicated that they were happier married than not married. In the Mauritian cultural context, marriage provides 'space' for personality growth and development that is typically not available in other personal contexts like bachelorhood and spinsterhood. Living together in relationships other than marriage (i.e., out of wed-lock) is not socially acceptable and thus frowned upon by Mauritian society.

All women interviewed were engaged in full-time employment. Subjects from the lower middle classes were engaged in employment activities, typically as administrative staff working for public and private organisations. The other groups were engaged in professions ranging from middle to upper management in public and private organisations. Occupation, therefore, provided a vital 'space' for personality development and hence, for increasing women's predisposition to participate in democracy. The views expressed by husbands also provided further insights in addition to those of the wives. Both sets of responses in the following discussion have been merged to formulate a picture that reveals possible 'areas' that could to be woven into the fabric of strategies used to build distance education systems.

The marriage/ family pattern

As the nuclear family becomes a more predominant mode of family life in Mauritius, there will be a gradual shift in the role of the middle-class women from that of procreation, cooking, and conjugal services to that of companionship. As capitalist societies advance and strengthen, men as a collective group become more fragmented and less cohesive (Haralambos, 1984). Women's increased access to education that allows them to earn qualifications, as well as their social status within the family and society, enables them to interact with men (i.e., husbands) on more equal terms. Women are typically seen as more worthy of companionship in the eyes of their husbands, and thus were more likely to benefit from spousal support. Nonetheless, most husbands indicated that they were unwilling to sacrifice their comfort (strongly contributed to by the wives' presence), if their wives' educational endeavours did not ultimately yield extra personal satisfaction.

This study found that women from the upper middle-class typically had more supportive husbands than those women of the middle and lower-middle classes. This finding reveals that upper middle-class women benefit from a 'social space' wherein decision-making is shared and their status improved to the mutual societal and economic benefit of family (and community). There also seems to be a direct relationship between the wife's economic independence gained via employment (especially in the case of Indo Mauritian families) and the way she could negotiate familial relationships with her mother-in-law.

Although beyond the scope of this study, and in the absence of much needed empirical studies, anecdotal information indicates the Indo Mauritian mother-in-law still retains much of the behavioural traits of the legendary 'Indian mother-in-law' characterised by a stern and often intolerant attitude towards her young daughter-in-law. The culturally determined joint-family

pattern reinforces this attitude. Recently, however, with more educated women in employment and the shift to the nuclear household pattern, the domineering position of the mother-in-law in the family is gradually being relinquished. Indo Mauritian households are thus gradually being transformed to that of a more democratic 'space' wherein wives and daughter-in-laws have greater say – a phenomena that is likely to strengthen and thus redress intra-family power imbalances in future generations.

The occupational pattern

Major hurdles remain in the expansion of the female workforce in Mauritius. Thus, women must personally negotiate their 'occupational social space' to accommodate formal on the job learning and training. Moreover, advances in technology will serve as a powerful tool to be used by women seeking to advance their education (and status). Greater skills and knowledge specialization will be needed by women to participate effectively in the rapidly emerging global information economy. Thus, women's educational opportunities must, by necessity, be reflective of and incorporate their occupational situation.

Access to education has allowed this study's subjects the opportunity and qualifications to climb the occupational ladder. To maintain and enhance their competitive edge, the women in this study indicated they are open to participating in 'lifelong learning' opportunities. Moreover, online education was seen as salvation by all women interviewed; they reported that online education enabled them to participate more effectively in society as a whole, whilst giving them the flexibility they need to accommodate their various roles and responsibilities in the '*marriage/family*' and '*occupation*' social spaces.

In short, *marriage/family* and occupation can be viewed as the 'social spaces' women use to shape their destinies – not the other way round. All couples interviewed were conscious that wives' participation in online education could lead to increased financial gain and economic stability for the family as a whole. Moreover, all the women interviewed (in varying degrees) stated they could count on their husbands for support in all spheres of their domestic life.

Nonetheless, this was not the case for women's *occupational* space. Indeed, these same women reported that while they felt had enough 'margin' to negotiate the time and space needed to engage in online distance learning, they still reported being cautious on how bring up the subject with their employer, irrespective of whether their superior was male or female. In other words, the women interviewed felt they did not have the same support from their employers (*occupational* space) as they did from their husbands (*marriage/family* space). Nonetheless, these same women all agreed that online learning offered potential (i.e., democratize access) to education.

These women also acknowledged that participation in online education results in the least possible disruption to their family life. Indeed, most husbands interviewed voiced unstinting support to their wives; however, the subtext of their 'unstinting support' was found to be premised on the rewards that would accrue to the family unit as whole as premised on their wives' ability to upgrade their qualifications.

Incorporating Online Distance Education

The above indicates that online distance education is viewed by most participants in this study as an intelligent means of accessing education for women. Online education, due to its inherent flexibility, was also primarily viewed as an 'unobtrusive presence' that no other modality of

distance education could provide. Among the Mauritian middle-class women interviewed, there were clearly strong opinions voiced in support of online education. It is hoped that the data presented here – albeit imperfect – will become self-explanatory over time with further research. Indeed, online distance learning is still not very familiar mode of education for this group of learners in Mauritius – women who need increased democratised access to lifelong learning opportunities if they are to benefit Mauritian society as a whole.

As plans for an open learning organisation move forward, the need for a niche market study to guide the organisation's development is clear. In concurring with Dirr (2003, p. 470) the researcher asserts that without a systematic empirical study examining the roles of learners (women, disabled, minorities, or otherwise), any distance education provision will be built upon the uninformed assumptions of policy-makers and practitioners. Such uninformed assumptions, moreover, may in fact work against learners' real needs and aspirations. Despite politicians' noble intentions designed to increase access to education in Mauritius, without a clear understanding of who will comprise this institutions target learner groups, as well as an clear understanding of the underlying specificities of these target learner groups, real access could tacitly remain closed large sections of the Mauritanian population – in this case women. At policy level, the following points are therefore suggested, important points that the author believes articulates the needs of the women learners (as expressed in the data):

1. A systematic niche market survey should be undertaken to ensure policy makers and educational leaders in Mauritius responds to the real – not perceived – needs of learners (and by logic, national and personal development needs as well).
2. To counteract learner isolation, incentives should be provided for women learners to engage in distance education. Such incentives could range from study leave from work, provision of study-grants, and tax-rebates. While tax-rebates already exist in Mauritius, the amount allowed should be reviewed with intent of increasing a sustainable level of incentive for learners to register in distance education courses. Student aid should be proportional to the course load taken by students.
3. To promote student retention, the provision of training facilities for learners (i.e., computer training) dynamic and responsive student support systems will be needed (Miller, Rainer, and Corley, 2003).
4. Care should be taken to add a component of flexibility, whereby deadlines are negotiable and courses are not only cohort-based; such provisions encourage flexible entry.
5. Ensure access to all necessary components of the distance education program; that is access to teachers, peers, administrative and academic support, and students' ability to register at a distance and manage the aspects of their registration.
6. Special arrangements should be made for students to gain necessary accreditation and recognition with the Mauritius Qualifications Authority/Tertiary Education Commission (especially in cases where courses were completed elsewhere, such as an overseas university, for example).
7. Support mechanisms to accommodate students with disabilities should also be provided. As yet in Mauritius, there is no provision for support of students with disabilities.

8. Development of a strong student feedback/ support infrastructure to aid learners studying online at a distance. This will involve budgeting for faculty training and investment in proper equipment and infrastructure.
9. Foster the concept of customer-centeredness at the open learning organisation, including the provision of incentives to the organisation to develop user-friendly packages aimed to support successful online learning.
10. To effectively redress the shortfall of learners as reported by the Mauritius Tertiary Education Commission (TEC, 1993), policies and legislation must be re-drafted to position 'distance education' as an attractive and viable option for learners in general, and women in particular. In the Mauritian context specifically, a social/ political infrastructure should be provided that supports the development of online learning at the open learning organisation. In addition, any such provision should benefit from a realistic budget to support it.

Discussion

To truly democratize access to education, women learners are encouraged to manage their time, exercise control over their own learning processes and goals, and to function effectively within the current constraints of their respective 'social spaces.' As elsewhere in the world, the development of women's self-motivation and self-directedness in any educational undertaking is important in Mauritius. Online education, more than any other type of educational modality, lends itself to a higher degree of learner control, and hence illustrates its potential to democratise access to education and thus improve the lot of Mauritian women, their families, and society as a whole.

References

- Bullock, S. (1994). *Women and Work*. London: Zed Books.
- Brockett, R. G., and Hiemstra, R. (1991). *Self-Direction in Adult Learning: Perspectives on Theory, Research, and Practice*. London and New York: Routledge. Retrieved on February 20, 2004 from: <http://www-distance.syr.edu/sdlindex.html>
- Brown, A. (1997). Designing for Learning: What are the essential features of an effective online course? *Australian Journal of Educational Technology*, 13(2) 115 – 126.
- Chang, W. L. (2003). The organisational innovation environment, self-directed learning, course design strategies, technology factors and the performance of Web-based training. *International Journal of Organisational Behavior* 6(4), 334 – 346. Retrieved February 23, 2004 from: <http://www.usq.edu./faculty/business/departments/hrm/HRMJournal/>
- Chant, S., and Mc Ilwaine, C. (1998). *Three Generations, Two Genders – women and men in a changing society*. London: Zed Books.
- Dirr, P. J. (2003). Distance education policy issues: Towards 2010. In Moore, M. G. and Anderson, W.G. (Eds.) *Handbook of Distance Education*. (p. 461-479). New Jersey: Lawrence Erlbaum Associates, Inc.
- Fonow, M. M., and Cook, J. A. (1991). (Eds.). *Beyond Methodology – feminist scholarship as lived research*. Indianapolis IN: Indiana University Press.

- Garrison, R.D. (2003). *Self-directed learning and distance education*. In Moore M. G. and Anderson W.G. (Eds.). *Handbook of Distance Education*. (p. 161-169). Mahwah NJ: Lawrence Erlbaum Associates.
- Government of Mauritius (2004). *Government of Mauritius Budget speech*. Retrieved November 23, 2004 from:
<http://www.pwc.com/Extweb/service.nsf/docid/79EAF40D6E58EC3D85256EAE0020A9AB>
- Guba, E., and Lincoln, Y. (1983). *Effective Evaluation*. London: Fossey Bass Publishers
- Haralambos, M., and Holborn, M. (1984). *Sociology: themes and perspectives*. (4th Ed.) London: Collins Educational.
- Harding, S. (1987). *Feminism and Methodology*. Bloomington, IN.: Indiana University Press
- Hartsock, N. (1990). Foucault on Power: A theory for women. In L. Nicholson (Ed.) *Feminism/post-modernism*. London: Routledge.
- Heward, C., and Bunwaree, S. (1999). *Gender, Education and Development: Beyond access to empowerment*. London: Zed Books
- Henri, F. (1989). Towards New Horizons for Women in Distance Education: International perspectives. *Journal of Distance Education*. 14(1). Retrieved September 30, 2004 from:
http://cade.athabascau.ca/vol4.1/12a_review-henri.html
- Kemp W. C. (2002). Persistence of Adult Learners in Distance Education. *The American Journal of Distance Education*, 16(2). 65 – 81.
- Kirkup, G., and von Prummer, C. (1990). Support and Connectedness: The needs of women distance education students. *Journal of Distance Education* 5(2) Retrieved September 30, 2004 from: http://cade.athabascau.ca/vol5.2/7_kirkup_and_von_prummer.html
- Kramarae, C. (2003). Gender Equity Online: When there is no door to knock on. In Moore, M. G. and Anderson, W.G. (Eds.) *Handbook of Distance Education*. (p. 261-272). Mahwah, NJ.: Lawrence Erlbaum Associates.
- Liddle, J., and Joshi, R. (1986). *Daughters of Independence: Gender, caste and class in India*. London: Zed Books
- Liddle, J., and Nakajima, S. (2002). *Rising Suns, Rising Daughters: Gender, class and power in Japan*. London: Zed Books
- May S. (1994). Women's Experiences as Distance Learners: Access and Technology. *Journal of Distance Education* 19(1). Retrieved September 30, 2004 from:
<http://cade.athabascau.ca/vol9.1/may.html>
- Miller, M. D., Rainer, R. K., and Corley, J. K (2003). Predictors of Engagement and Participation in an On-Line Course . *Online Journal of Distance Learning Administration*, 4(1). Retrieved on July 19, 2004 from: <http://www.westga.edu7Edistance/ojdl/spring61/spring61.htm>

- Moore, M., and Kearsley, G. (1996). *Distance Education: A systems view*. Belmont, CA.: Wadsworth.
- O'Connell, H. (1994). *Women and the Family*. London: Zed Books
- Parsuramen, A. (1994). *Ministerial Consultation on School Drop-out and Adolescent Pregnancy: The case of Mauritius*. Port-Louis: Ministry of Education and Science.
- Ramazanoglu C. (1993). *Up against Foucault: Explorations of some tension between Foucault and feminism*. London: Routledge
- Rumble G. (2001). E-education: Whose benefits, whose costs? International Research Foundation for Open Learning. Retrieved on October 8, 2004 from:
http://www.iec.ac.uk/resources/e_education_costs.pdf
- Spronk, B. (1996). *Gender issues in distance education and training*. Athabasca University Masters in Distance Education course module MMDE 651. Athabasca, Canada: Athabasca University Press
- Stanworth, M. (1981). *Gender and Schooling: a study of gender divisions in the classroom*. London: Women's Researchers and Resources Centre.
- TEC. (2003). *Participation in Tertiary Education 2002*. Mauritius: Tertiary Education Commission
- UNESCO. (2001). Education for Peace, Human Rights and Democracy in the UNESCO Context. Retrieved October 17, 2005 from: www.unesco.org/education/ue/documentation/Democracy.pdf
- Universite Virtuelle: les premiers jalons. (2003, April 06). *Week-end*, p. A4.



November – 2005

Tensions in Learner Support and Tutor Support in Tertiary Web-based English Language Education in China

Tong Wang

Beijing Foreign Studies University, China

Abstract

Based on the findings of a national survey conducted in 2004 designed to examine the support systems for both learners and tutors engaged in tertiary-level Web-based English education in mainland China, this paper reports the findings of secondary analysis by identifying the tensions in the current learner and tutor support systems.

For *learner support*, four tensions were analyzed: 1) vigorous institutional learner support efforts versus learner utilization of the provisions; 2) learner qualities development versus academic support; 3) learner technical competence versus learner participation in online services; and 4) the relationship of face-to-face components and online components in learner support system design.

For *tutor support*, four tensions were identified: 1) institutional conceptual understanding versus the actual practices; 2) tutor's enthusiasm versus tutor's perception of online education; 3) tutor responsibilities versus tutor commitment; and 4) current tutor support service repertoire versus tutor improvement areas.

The paper analyzes possible causes for the tensions and proposes some solutions to address these tensions.

Keywords: learner support; tutor support; China; Web-based; tertiary; English language education; tension

Editor's Note: Descriptive findings of the survey were reported in three earlier published papers regarding learner support and tutor support systems (Wang, 2004), resources development and delivery systems (Cao, 2004), and assessment systems (Tang, 2004) at tertiary-level Web-based English education in China. This paper is a secondary analysis of the survey findings based on Wang's preliminary explorations of the descriptive features of learner support and tutor support systems. Tensions are identified and analyzed in this paper.

Introduction

Since 1998, the Chinese Ministry of Education has approved of 68 institutions of higher learning experimenting with Web-based education in China. Although still in its experimental phase, Web-based education in China has grown into both a promising and robust mode of educational

delivery, as evidenced by approximately 1,373,000 registered students as of the end of 2002 (China Ministry of Education, 2004). As of June of 2005, 3,000,000 students majoring in 153 disciplines were registered at 2,800 learning centers across China (Liu, 2005). The Chinese Ministry of Education attaches great importance to the development of online education, which is deemed important for achieving the lifelong educational mission of the country (China Ministry of Education, 2000, 2000, 2002, 2003, 2003, 2004).

Considering the rapid development of this new educational paradigm, it is paramount to acquire a systemic view of the operation of Web-based education at both macro and micro levels, which historically have been under-investigated compared to the efforts of other governmental organizations, academics, and research bodies (Haddad and Draxler, 2002; Bell, Bush, Nicholson, O'Brien, and Tran, 2002; The E-learning Advisory Group, 2002; Advisory Committee for Online Learning, 2001; The Sloan Consortium, 2003).

Against this backdrop, in early 2004 a national survey on tertiary-level Web-based English education in China was conducted to investigate current systems of learner support, tutor support, resources development and delivery, assessment, and quality assurance at the levels of institutional decision makers, tutors, and learners. Specifically, this national survey endeavored to explore the five questions below:

1. What support services do tutors and learners need?
2. What support service repertoire is provided for them?
3. How do they receive the support services?
4. What do they perceive the effects of the support services to be?
5. What support initiatives are Chinese online institutions currently planning?

For the purpose of method and data triangulation, the survey was administered to institutional decision makers, tutors, and learners.

Summary of the Descriptive Findings of 2004 National Survey

This survey was administered between January–May 2004. Two questionnaires were administered to tertiary-level English online learners and tutors respectively. Structured interviews were also conducted with institutional decision makers responsible for academic affairs. The data was collected, analyzed, and compared between the three subject groups for consistency in their responses. Figure 1 below illustrates the seven step research procedure used for this study.

Figure 1. Seven step research design and data collection, analysis, and dissemination procedure

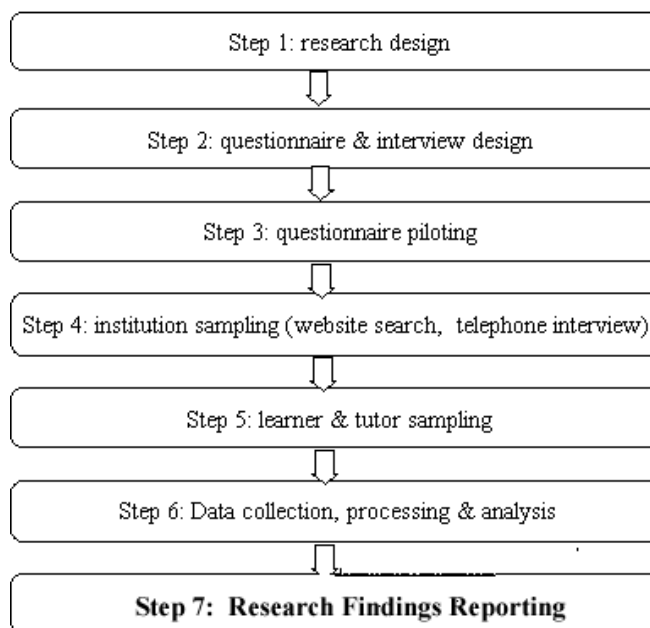

Subjects

Three subject groups were identified for this study, each meeting different sampling criteria. Institutions providing online English degree programs for at least one year were considered as valid institutional subjects. Twelve out of 68 online institutes of higher education met the criteria and eight confirmed their participation in the project. For logistical reasons, the research was conducted at the headquarters of the eight institutions. The institutions ($n = 8$) participating in this study were geographically located across the Chinese mainland. Institutional dispersion is described in Table 1 on the next page.

Table 1. Information on subject institutions

Institution	City	Years of Online Programme Operation	Institution Type
1	Beijing (Northeast China)	3	Comprehensive
2	Beijing (Northeast China)	3	Language education
3	Beijing (Northeast China)	4	Comprehensive
4	Shanghai (Mideast China)	3	Comprehensive
5	Shanghai (Mideast China)	3	Normal
6	Xi'an (Northwest China)	3	Normal
7	Wuhan (Middle China)	3	Normal
8	Fuzhou (Southeast China)	3	Normal

The sampling criteria for selecting tutor subjects were: four tutors ($n = 4$) (two full-time and two part-time tutors) with at least one year tutoring experience at the headquarters of each of the eight institutions. More tutors ($n = 2$) were selected if the English learner population at the headquarters exceeded 1,000. Part-time tutors were chosen if there were no/ insufficient full-time tutors at the institutions. Forty eight ($n = 48$) questionnaires were administered; thirty five ($n = 35$) questionnaires were returned from the tutors, resulting in a return rate of 72.9 percent.

The sampling criteria for selecting learner subjects: Two intact classes of learners (one Bachelor of Arts program and one Diploma program) were selected for each school. The class size varied among the participating institutions. At total of 560 questionnaires were administered to the two intact classes of learners; two hundred and sixty one ($n = 261$) learner questionnaires were returned, resulting in a return rate of 46.6 percent.

Method and Statistical Analysis

For method and data triangulation, the survey was administered to institutional decision makers, tutors, and learners. The survey data was processed with SPSS software (version 11.0) and analyzed to generate a descriptive picture of learner support system for tertiary-level Web-based English education in China. Forty-six ($n = 46$) unfinished/ spoiled questionnaires were declared invalid; two-hundred fifteen ($n = 215$) learner questionnaires were considered valid. Given the limited tutor and management sample size and the small number of the uncompleted questions, this treatment was conducted only with the learner respondents. The valid sample size is reported as:

$$n \text{ learner} = 215; n \text{ tutor} = 35; n \text{ management} = 8$$

Research Questions on Learner Support Systems

The national survey addressed the following research questions at the levels of conception, operation, and technical.

At the conceptual level:

1. How do Chinese tertiary-level institutional decision makers conceptualize learner support for Web-based English education?
2. How do Chinese tutors involved in tertiary-level Web-based English programs conceptualize learner support for Web-based English education?
3. How do Chinese students enrolled in tertiary-level Web-based English programs conceptualize learner support for Web-based English education?

At the service provision and reception (operation) level:

4. What learner support services are needed by tertiary-level online English learners?
5. What online and offline support services are provided by Chinese online institutions?
6. How are the support services received by the learners?

7. What are the perceived effects of the support services by the learners?
8. What difficulties do the learners confront when utilizing learner support services?

At the technical level:

9. What technical functionalities are employed by Chinese online institutions in their learner support system for tertiary-level Web-based English education?
10. How are the functionalities received by the learners?
11. What technical difficulties do the learners confront when utilizing the functionalities?

Research Questions on Tutor Support Systems

At the conceptual level:

1. How do institutional decision makers conceptualize tutor support in tertiary-level Web-based English education?
2. How do tutors conceptualize Web-based education?

At the service provision and reception (operation) level:

3. What are the job specifications for tutors?
4. What support services do tutors need?
5. What institutional support services are provided for tutors?
6. How are the support services received by tutors?
7. What tutor support measures are going to be taken by the institutional decision makers in the near future?

At the quality assurance (conceptual) level:

8. How is the overall tutoring quality in tertiary-level Web-based English education in China?
9. What institutional quality assurance measures are taken to ensure the tutoring quality in tertiary-level Web-based English education?

Basic Findings on Learner Support Systems

Conceptually, all parties (management, tutors, and learners) engaged in Web-based education agreed that “learner support” was important to effective provision of online learning and teaching. Management, tutors, and learners also placed high importance on learner support.

Operationally, the integration of online and offline learner support system was reported by survey respondents to be taking shape. All online institutions in this study reported providing a blend of

online and offline learner support services, although the ratio between the two delivery means varied between institutions. Both synchronous and asynchronous communication tools were reported being used to engage learners. Despite reporting obstacles, management continued to expand their provision of institutional learner support initiatives. Students also reported their use of learner support services to be generally positive, although the actual support services offered was found to vary between the eight institutions. In summary, learner support was gaining attention from all parties engaged in Web-based English education in China, and efforts are underway to improve the provision of learner support services.

Some important issues emerged from this study. First, learners did not report technical constraints to be a major difficulty. On the other hand, the data collected revealed that students were found to lack autonomous learning qualities needed for self-directed learning. Such lack of autonomous learner qualities not only caused learning problems for the students, it resulted in their ineffective use of learner support services available to them. The data also revealed that both online and offline learner support services must be better designed to benefit online English language learners reliant on integrated provision of English language acquisition skills (i.e., listening, speaking, reading, and writing).

Basic Findings on Tutor Support Systems

Conceptually, tutor support should enjoy more institutional attention. However, some institutions reported insufficient institutional control over their tutors. Indeed, because the majority of tutors worked on a part-time basis for the online schools, administrative control over tutors tended to be insufficient. Moreover, when compared to learner support, tutor support typically did not enjoy equal attention from institutional decision makers.

Despite control measures (i.e., occasional inspection visits and learner evaluations of tutor performance) quality assurance measures were generally found to be non-systematic. As such, more quality assurance and enhancement measures should be implemented to monitor base-line tutor quality, and track and monitor their progress.

While indicating that they faced multi-faceted challenges, English teachers participating in this study nonetheless reported that they embraced Web-based English education.

The national survey findings also revealed tensions between managements' philosophies and their good-willed intentions versus their actual practices in terms of support offered to students and tutors. Several important questions emerged; questions demanding further exploration are:

1. Why do learners' under-utilize the online support services?
2. Why do online learners prefer traditional, face-to-face learning?
3. What is the relationship between face-to-face components and online components in support system design?
4. How can tutors be better supported in their tutoring process?

This paper addresses the above questions by identifying four tensions in learner support systems and tutor support systems used for tertiary English online education in China.

Results and Discussion Part 1: Tensions in learner support

Tension 1: Vigorous institutional learner support efforts vs. scant learner utilization of the provisions

Conceptually, there was a consensus among the managers surveyed as to the importance of providing learner support to facilitate learning. Seven of eight managers surveyed reported that a blended delivery format of online and offline support services as the predominant means of support delivery. Both synchronous and asynchronous communication was reported at varied levels among the online institutions. Tables 2, 3, 4, below outlines the current learner support service repertoire offered by these eight institutions.

Table 2. Provision of synchronous communication in learner support reported by the eight institutions

Synchronous Communication	Number of Institutions (n = 8)
Voice and Text	6
Text	2
Voice	1
Voice and Text and Video	1

Table 3. Provision of asynchronous communication in learner support reported by the eight institutions

Asynchronous Communication	Number of Institutions (n = 8)
Course forum	6
Free discussion forum	5
Formative assessment	5
Tutorial playback	4
Listserv	3
Online library	1
Class homepage	1

Table 4. Provision of offline learner support services reported by the eight institutions

Offline Services	Number of Institutions (n = 8)
Tutorial	8
Telephone helpdesk	7
Student organization	6
Study group	5
Lecture	2
Extracurricular activities	1

Tables 2, 3, and 4 above show that offline services still dominate the learner support system design with all institutions providing face-to-face tutorials, and seven out of the eight schools offering helpdesk services. Nonetheless, because the majority of the online institutions surveyed were adding an online component to their support system at the time of this survey, a blended support model was found to be emerging. Indeed, both synchronous and asynchronous

communication tools were reported to be available for the learners, thus enriching the learner support service, as listed in Table 5.

Table 5. Service contents of learner support provisions reported by the eight institutions

Service Contents	Number of Institutions (<i>n</i> = 8)
Technical support	5
Online learning strategies	4
English learning strategies	4
Course learning strategies	4
Course learning support	4
Affective support	3

Table 5 outlines the range of support services available to online learners of English in China. Note that this table shows that institutional efforts are made by approximately half of the schools to support learners technically, meta-cognitively, cognitively, and affectively.

Were these institutional efforts well received by the learners? The utilization rate of the online services was found to be low according to the survey data (see Table 6). Compared to online services, offline services enjoyed no better learner utilization except for face-to-face tutorials.

Table 6. Learners' ratings of online learner support services

Online Services	Learner Participation ("often participate" choice)
Synchronous programmes (text communication)	20.5%
Synchronous programmes (voice and video and text communication)	20.0%
Synchronous programmes (voice and text communication)	16.7%
Synchronous programmes (voice and video communication)	15.8%
Synchronous programmes (voice communication)	12.6%
Formative assessment	33.5%
Tutorial playback	23.7%
Course forum	17.7%
Free discussion forum	16.3%
Class homepage	14.0%
Listserv	11.6%
Online library	9.8%

Table 7. Learners’ ratings of offline learner support services

Offline Services	Learner Participation (“often participate” choice)
Tutorial	79.5%
Lecture	20.9%
Study group	15.3%
Student organization	13.0%
Telephone helpdesk	10.2%
Extracurricular activities	7.4%

The problem that emerged was that online learners still preferred the conventional classroom-based learning style of interacting with, and receiving knowledge from, their teachers face-to-face, despite the fact that there were alternative online support provisions available to them. This disconnect between online students’ use of online learner support versus conventional offline learner support available reveal that Chinese online learners are behaving like offline learners, in that they are “stubbornly” sticking to using limited, face-to-face offline learner support services while under-utilizing more plentiful online learner support provisions. This apparent deadlock between online support provisions and conventional face-to-face tutorials needs to be addressed. The tension between institutional support efforts and low learner utilization rates of online services calls for in-depth investigation into the question: “Is the low utilization rate due to the lack of self-directed learner qualities? Ineffective learning strategies? Technical incompetence on the part of the learner? Or poor service quality? Table 8 below provides part of the answer to the questions.

Table 8. Five major learner difficulties identified in utilizing learner support services

Learner Difficulties in Using Services	Percentage of Learners
Poor time management	47.4%
Ignorance of available services	37.2%
Unawareness of importance of services	29.8%
Technical constraints	27.9%
Limited items of high-quality support services	26.9%

From this data, it is apparent that the major contributing factors underlying the low utilization rates of online learner support reported by online students stem from their lack of self-directed learner qualities and learning strategies. This finding suggests that more attention must be paid to improving learner’s time management skills, self-regulation, and self-directed learning strategies from the beginning (Zimmerman, 1998, 2000; Zariski and Styles, 2000). In other words, in order to bring the blended learner support services into full play, it is important for students to develop well-rounded, self-directed learner qualities and effective learning strategies from the beginning (Wang, 2005).

Tension 2: Learner qualities development vs. academic support

Table 9 on the next page outlines the survey findings, which reveal that learners typically encounter a number of difficulties.

Table 9. Perceived difficulties by learners in the learning process

Learner Difficulties	Percentage of Learners
1. Heavy study load	54.6%
2. Lacking autonomous leaning strategies	34.7%
3. Inability in using resources effectively	34.3%
4. Lacking time management skills	33.3%
5. High difficulty level of textbooks	30.6%

It is noted that of the five learner difficulties outlined above in Table 9, meta-cognitive strategies (i.e., individual’s knowledge on his/ her own cognitive process) (Flavell, 1976; 1987) and the lack of self-directed learner qualities (i.e., resources management strategies) (Pintrich and De Groot, 1990) were identified as core problems hindering students’ effective use of online learner support provisions. In light of this finding, the design of learner support systems must aim to support the dual-objectives of 1) facilitate students’ sense and use of self-directed learning strategies (Moore, 1972); and 2) provision of continuous academic (course-based) support during students’ learning process. Indeed, of those institutions surveyed the data revealed that there is currently a very real danger in over-targeting course-based support at the expense of developing well-rounded self-directed learner qualities in students. As such, these institutions may fall into the trap of chasing small gains, while at the same time ignoring the larger issues of training learners capable of learning. Table 4 illustrates that the dual objectives were not even effectively set by half of the online institutions. Table 10 below illustrates the dilemma currently faced by these institutions.

Table 10. Major institutional obstacles in providing learner support

Obstacles in Providing Learner Support	Number of Institutions (<i>n</i> = 8)
Learner lacking autonomous learner qualities	7
Institution lacking technical capability	6
Institution lacking human resources	3
Financial constraints	2

The majority of the online institutions reported that they faced the problem of students lacking all-round learner qualities, which subsequently hindered them in providing effective learner support initiatives. These problems were moreover compounded by institutions’ lack of technical capacity, human resource capacity, and the funds need to expand such necessary capacity. Despite these obstacles, all managers reported that they would continue their efforts in providing learner support. Indeed, among the eight Chinese online institutes surveyed, some had already paid emphasis on student re-education. For example, one institute launched a “whole person” campaign aimed at transforming conventional students into competent, self-directed, online learners (for details visit http://www.beiwaionline.com/degree/zx/daohang/t20040924_1110.htm).

In a sense, Chinese online institutions have been given the mission of emancipating students from their engrained learning habits that enslave themselves to conventional receiving-type learning styles, towards the new, self-directed constructivist learning styles. Only when this objective is achieved, however, can learners make better use of the blended support provisions emerging and currently on offer.

Tension 3: Learner technical competence vs. learner participation in online services

The survey yielded optimistic findings on learner access to the Internet (Table 11) and learner computer skills prior to enrollment (Table 12).

Table 11. Learner access to the Internet

Access to the Internet	Percentage of Learners
ADSL	52.6%
Modem	22.3%
LAN	12.1%
Other	13.0%

Table 12. Computer skills of the learners prior to enrollment

Computer Skills	Percentage of Learners
Computer professional	4.5%
Skillful use of the computer and ability to solve technical problems	22.7%
Skillfully use of most application software	35.2%
Use of simple application software	33.6%
Do not know how to use the computer	4.0%

Theoretically, learner access to the Internet and concomitant computer skills to effectively use the Internet (as presented in Tables 11-12) should be found conducive to learner utilization of various online services. In actual practice, however, it was found that having these skills did not serve students well. In this case, students’ technical competence and Internet access did not successfully translate into successful use of online support services as shown in Table 6. Indeed, it is naïve to think that providing students with technical support would automatically translate into their becoming competent, resourceful online learners. As such, online institutions throughout China are being challenged to change learners’ current, deep rooted preference for traditional face-to-face support scenarios to that of integrated, offline support services.

Tension 4: face-to-face component vs. online component in the design of learner support system

The survey findings show students’ strong preference for face-to-face components in the learner support system (Table 6). When questioned about their expectations on online support services, 38.1 percent of learners surveyed chose “tutorials supplemented with online learning” compared to 25.9 percent of learners choice of “online learning supplemented with tutorials.” Given that online support services were under-exploited and generally un-favoured by Chinese online English language learners, online services provided by some institutions was found to be simply that of lip-service. Thus this finding suggests that it is very important to research the fundamental design of learner support systems for Web-based English education. From our research, a number of key questions arose: How should online institutions holistically integrate online components in their overall learner support system design? What is the relationship between online support and offline support? What are the roles and functions of online learner support compared to that of offline learner support? Is more online support better? If not, what support services should go online and what should go offline? What English language skills can be better developed online

and what skills can be better developed offline? What online functionalities best support English language education? What functionalities can be used to deliver what types of learner support services for the development of various English language skills (i.e., reading, writing, speaking)?

Part Two: Tensions in Tutor Support

Tension 1: Institutional conceptual understanding vs. institutional practices

During the structured interviews conducted with all eight institutional decision makers, consensus was achieved that tutors play a central role in online education. It is therefore important to support tutors in their work. Current reality, however, does not match this good-will as articulated by the decision makers surveyed. In terms of tutor support, only five of the eight online institutions had established a center/ department providing tutor support services. And even though seven of eight online institutions have established a specialized learner support center, the concept of tutor support was nonetheless viewed as secondary by some.

There appears to be valid justifications for the current practice: at the time of this survey, all online institutions in China were still in their pilot phase and were busy setting-up their infrastructure. As such, they had little resources available to design a tutor support system. In addition, part-time – not full-time – tutors comprised the majority of the teaching faculty and were typically borrowed from traditional campus based institutions. As a result, it was understandable that most tutors surveyed typically employed tried-and-true campus-based teaching experiences to form the basis of their online teaching practices.

Nonetheless, this lack of systematic tutor support and training has had a domino-effect on Chinese online education system. Because most tutors currently do not have an in-depth understanding of online education as a unique teaching pedagogy, they unknowingly perpetuate and clone traditional face-to-face practices in their tutoring process, which in turn reinforces passive learning habits amongst students, rather than transforming them into self-directed learners capable of effectively learning online.

Tutors and tutoring strategies, as with learners and learning strategies, must be transformed in order to realize the full potential online education offers. Teachers and tutors are on the frontline of learning-teaching interactions – they are in the position to both directly and positively influence learners and their learning strategies. However, only after tutors themselves grasp an in-depth understanding of the pedagogical dynamics of online education, will they be fully equipped to effectively facilitate students to develop into competent online learners (D'Antoni, 2003). Tutor support and training serves this purpose and cannot be overemphasized (Duggleby, 2000; Salmon, 2000; Pajo and Wallace, 2001; Beaudoin, 1990).

Tension 2: Tutor enthusiasm in participation in online education vs. tutor perception of online education

Table 13 on the next page shows that tutors that responded to this survey expressed high motivation in their participation in online education.

Table 13. Tutors' self-reported motivation in participating in Web-based English education

Tutors' Motivation	Percentage of Tutors
High	62.9%
Average	37.1%
Low	0.0%

According to the survey data, tutors' reporting high motivation can be explained by the following: tutors' ease and ability to research more effectively using online Information and Communication Technologies (ICTs); the opportunity to experiment with ICTs for teaching purposes; managements' provision of ICT for teaching and learning; the ability to teach greater numbers students online; and encouragement by school management. In sum, tutors reported to be generally motivated to participate in online education.

Does this favorable participation rate, however, indicate that tutors truly identify with this new mode of education? How did the tutors conceptualize online education? Indeed, the relevant survey data as outlined in Table 14 is not as positive as those outlined in Table 13. Table 14 reports tutors' conviction in capacity of online education in developing qualified English majors.

Table 14. Tutor conviction in the capability of Web-based education in developing qualified English majors

Conviction of Tutors in Web-based Education	Percentage of Tutors
High	22.9%
Average	62.9%
Low	11.4%
No	2.9%

Though they reported high levels of support for online education (see Table 13) the data in Table 14 shows that only 23 percent of tutors questioned the capacity of online learning to create quality of online learning outcomes. Tutors' conservative view is partly justifiable: online education, as a new learning and tutoring mode in China, still has a long way to go in terms of understanding, acceptance, and recognition from policymakers, academia, and the general public. Moreover, understanding and recognition of the new education paradigm will not happen automatically for any group, tutors included. Hence, it is important that scaffolding (such as tutor training, process-based tutor support) be introduced to facilitate the transformation of tutor conceptions and tutoring practices (Ragan and Terheggen, 2002).

Tension 3: Tutor responsibilities vs. tutor commitment

The composition of tutoring faculty was found to be a bottleneck for the majority of the eight online institutions. Most of the eight online institutions surveyed did not have sufficient tenure-track positions prescribed by their parent universities. Faced with the thin faculty size, online institutions in China must typically "borrow" English teachers from other schools. In this survey, only one school reported that it had sufficient full-time tutors, while the remaining seven reported "borrowing tutors" from other schools. Tutors were "lent" to the online institutions by either the English department or School of Foreign Languages within the same university or by partner universities. In short, part-time tutors were not employed exclusively by the online schools. As a result, institutional control over the part-time tutors was found lacking. Given the huge numbers of students seeking English education in China, tertiary English teachers are a highly sought-after

resource, a fact that makes it very difficult for the online institutions to employ contract-based tutors from other sources. This picture is presented in Table 15.

Table 15. Faculty make-up among Chinese online institutions

Faculty Make-up	Number of Institutions (<i>n</i> = 8)
A few full-time tutors with many part-timers	5
No full-time tutors	2
Enough full-time tutors	1

To complicate matters, the workload for tertiary English teachers in China is typically heavier compared to other teachers teaching other tertiary subjects (i.e., the average weekly teaching load for English teachers is 12 contact hours). As such, it can be conjectured that only limited commitment and efforts can be assured.

This conjecture is supported by the survey data; it was found that online tutors teaching part-time cannot insufficiently fulfill their responsibilities. Tutor responsibilities comprise giving face-to-face tutorials, conducting online lectures, marking learners’ assignments, communicating with learners by telephone and email, and commenting on assignments in class. Among the required tasks, some posed as difficulties as reported by the tutors (see Table 16).

Table 16. Difficult job specifications for tutors (tutors’ perspective)

Difficult Job Specifications for Tutors	Percentage of Tutors
Marking assignments	45.7%
Communication with learners	25.7%
Commenting on assignments in class	22.9%

The three difficult tutoring tasks identified in Table 16 share a common feature: tutors must dedicate more time and effort to teaching learners online as compared to traditional classroom teaching situations (Bonk, 2001).

To ensure they hire and retain committed high-quality tutors, it is important that online institutions design a contract system reflective of the extra effort tutors need to teach online. High level management of parent universities must also develop a strategic and in-depth understanding of online education; it is suggested there that this can be achieved by implementing preferential policies and offering more tenure-tracking positions.

Tension 4: Current tutor support repertoire vs. tutor improvement needs

The survey data revealed that tutors had their perceived areas for improvement (see Table 17 on the next page).

Table 17. Perceived areas for tutor improvement (tutors' perspective)

Areas for Tutor Improvement	Percentage of Tutors
Mastery of Computer Assisted Language Learning (CALL) theories	60.0%
Sufficient time and energy committed to Web-based education	45.7%
Computer and Internet skills	42.9%
Mastery of English Language Teaching (ELT) theories	28.6%
Feelings of belonging to the online institution	25.7%

All the above self-perceived tutor improvement areas need long-term and systematic support. In contrast, the support provided by the online institutions at the time of this study was mostly based on short-term measures (Table 18).

Table 18. Tutor support services provided by online institutions

Tutor Support Services	Number of Institutions Providing Services (n = 8)
Program orientation	8
Technical training	8
Free email account	7
Course-related training	4
Setting up collaborative tutoring group	4
Teleconferencing	4
Office phone	4
Lesson preparation in groups	3
Online tutor forums	3
Free tutoring and research resources related to Web-based education	1
Symposium on Web-based education	1

Comparing tutors' perceived areas that need improvement versus tutor support provisions available at the time of this report, it can be concluded that current tutor support services mainly reside at the operational level, and such provision aims at supporting tutors in the administration of their day-to-day job responsibilities. Tutors, however, reported the need for more systematic and in-depth support and guidance in building a sound knowledge base and skill set needed to support both the Computer Assisted Language Learning (CALL) and English Language Teaching (ELT) fields. Tutors also reported that they lacked the time they need to effectively teach online, and lacked a committed sense of belongingness to the online institutions for which they work. Long-term support provisions are therefore needed to address the tutor improvement areas at a deeper level.

Conclusion

As a distinctive mode, Web-based education requires support systems that fundamentally differ from those used for classroom-based education. The tensions identified in the survey deserve careful and in-depth investigation into the root causes and all potential solutions. The tensions bring forth not only signals for change in both learner and tutor support systems design, but is also a harbinger for educational policy makers in China about the purpose of education and the nature of online, Web-based learning and teaching in the exam-oriented Chinese educational

context. In an emancipatory sense, Web-based education holds the key to learner-autonomy, which is fundamentally different from traditional face-to-face passive learner classroom-based contexts. In the same vein, Web-based education also acts to transform teachers' and tutors' roles and similarly requires systematic tutor support provisions (Gu, 2005). As a result, process-based research is needed to investigate the ecological and contextual factors contributing to the tensions.

Acknowledgements

1. The author sincerely thanks her supervisors for their guidance and support. They are Professor David Wood, Professor Charles Crook of the Nottingham University (UK) and Professor Yueguo Gu of Beijing Foreign Studies University (China).
2. This paper was presented at CRIDALA/DEC 2005 (Conference on Research in Distance and Adult Learning in Asia) hosted by the Open University of Hong Kong.

References

- Advisory Committee for Online Learning (2001). *The E-Learning E-Solution in Colleges and Universities*. Ottawa, Canada.
- Beaudoin, M. (1990). The Instructor's Changing Role in Distance Education. *American Journal of Distance Education*, 4(2), 21 – 30.
- Bell, M., Bush, D, Nicholson, P., O'Brien, D., and Tran, T. (2002). *Universities Online – A Survey of Online Education and Services in Australia*. Commonwealth of Australia.
- Bonk, C. J. (2001). *Online Teaching in an Online World*. Bloomington, IN.: CourseShare.com.
- Cao, W. (2004). Resource Development and Provision. In Y. G. Gu, (Ed.) *Exploring Online Education*. In English. Beijing: Foreign Language Teaching and Research Press.
- China Ministry of Education. (2000). *Document on Initiatives in Piloting Online Education in China*. In Mandarin. Retrieved November 6, 2005 from:
<http://www.moe.edu.cn/edoas/website18/info4496.htm>
- China Ministry of Education. (2000). *Document on Initiatives in Reforming Tertiary Education in China*. In Mandarin. Retrieved December 18, 2004 from:
<http://www.moe.edu.cn/edoas/website18/info4267.htm>
- China Ministry of Education. (2002). *List of Approved Universities Piloting Online Education in China*. In Mandarin. Retrieved December 19, 2004 from:
<http://www.moe.edu.cn/edoas/website18/info4659.htm>
- China Ministry of Education. (2003). Document on Establishing the National Online Consortium of Teacher Education. In Mandarin. Retrieved December 18, 2004 from:
<http://www.moe.edu.cn/edoas/website18/info12034.htm>
- China Ministry of Education. (2003). *Regulation on Establishing Local Learning Centers*. In Mandarin. Retrieved December 8, 2004 from:
<http://www.moe.edu.cn/edoas/website18/info4493.htm>

- China Ministry of Education. (2004). *Survey of the Educational Reform and Development in China*. In Mandarin. Retrieved November 20, 2004 from: <http://www.moe.edu.cn>
- China Ministry of Education. (2004). *National Plan of Education for 2003-2007*. In Mandarin. Retrieved December 20, 2004 from: <http://www.moe.edu.cn/edoas/website18/info3338.htm>
- D'Antoni, S. (2003). *The Virtual University: Messages and lessons learned*. UNESCO.
- Duggleby, J. (2000). *How to be an Online Tutor*. Hampshire, UK.: Gower.
- Flavell, J. H. (1976). Metacognitive Aspects of Problem Solving. In Resnick (Ed.) *The Nature of Intelligence* (p. 231-235). Hillsdale, NJ.: Lawrence Erlbaum.
- Flavell, J. H. (1987). Speculations about the Nature and Development of Metacognition. In Weinert and Kluwe (Eds.) *Metacognition, Motivation and Understanding* (p. 21-29). Hillsdale, NJ.: LEA.
- Gu, Y. G. (2005). An Ecological Model for Online Education. In Gu (Ed.) *Exploring Online Education (II) (in press)*. Beijing CN: Foreign Language Teaching and Research Press.
- Haddad, W. D., and Draxler, A. (2002). *Technologies for Education – Potentials, Parameters, and Prospects*. UNESCO.
- Liu, Y. (2005). Providing Appropriate Support and Quality Assurance. Keynote Address at the *3rd Conference on Research in Distance and Adult Learning in Asia*. Hong Kong, China.
- Moore, M. (1972). Learner Autonomy: The Second Dimension of Independent Learning. *Convergence* V(2), 76 – 88.
- Pajo, K., and Wallace, C. (2001). Barriers to the Uptake of Web-based Technology by University Teachers. *Journal of Distance Education* 16(1), 70 – 84.
- Pintrich, P. R., and De Groot, E. V. (1990). Motivational and Self-Regulated Learning Components of Classroom Academic Performance. *Journal of Educational Psychology* 82(1), 33 – 40.
- Ragan, L. C., and Terheggen, S. L. (2002). *Effective Workload Management Strategies for the Online Environment*. Philadelphia, PA.: The Pennsylvania State University.
- Salmon, G. (2000). *E-Moderating: The key to teaching and learning online*. London, UK.: Kogan Page Press.
- Tang, J. L. (2004). Assessment in Tertiary-level Online Degree-granting Program in English Language Education in China. In Y. G. Gu (Ed.) *Exploring Online Education*. In English. Beijing China: Foreign Language Teaching and Research Press.
- The E-Learning Advisory Group, New Zealand. (2002). *Highways and Pathways – Exploring New Zealand's E-Learning Opportunities*. Wellington New Zealand: Ministry of Education Press.

- The Sloan Consortium. (2003). *Sizing the Opportunities – The Quality and Extent of Online Education in the United States, 2002 and 2003*. Retrieved July 12, 2005 from:
<http://www.sloan-c.org/resources/survey03.asp>
- Wang, T. (2004). Learner Support and Tutor Support in Web-based Degree Programs in Tertiary-level English Education in China. In Y. G. Gu (Ed.) *Exploring Online Education*. In English. Beijing, China: Foreign Language Teaching and Research Press.
- Wang, T. (in press). A Case Study of BeiwaiOnline Learner Support System Design and Practices. In Gu (Ed.) *Exploring Online Education (II)* . In Mandarin. Beijing, China: Foreign Language Teaching and Research Press.
- Zariski, A., and Styles, I. (2000). Enhancing student strategies for online learning. In Herrmann and Kulski (Eds.) *Flexible Futures in Tertiary Teaching. Proceedings of the 9th Annual Teaching Learning Forum, 2-4 February 2000*. Perth, Australia: Curtin University of Technology.
- Zimmerman, B. J. (1998). Academic Studying and the Development of Personal Skill: A Self-Regulatory Perspective. *Educational Psychologist, 33*(2/3), 73 – 86.
- Zimmerman, B. J. (2000). Attaining Self-Regulation: A Social Cognitive Perspective. In P. R. Pintrich and M. Zeidner (Eds.) *Handbook of Self-Regulation* (p 13-41). San Diego, CA.: Academic Press.



November – 2005

The Effects of Linguistic Qualifiers and Intensifiers on Group Interaction and Performance in Computer-Supported Collaborative Argumentation

Allan C. Jeong
Florida State University

Abstract

This study tested the effects of linguistic qualifiers and intensifiers on the number and types of replies elicited per argument and per challenge posted in online debates. To facilitate collaborative argumentation, thirty-two students (22 females, 10 males) enrolled in a graduate-level online course classified and labeled their messages as arguments, challenges, supporting evidence, or explanations prior to posting each message. The findings showed that qualified arguments elicited 41 percent fewer replies (effect size = -.64), and the reduction in replies was greatest when qualified arguments were presented by females than males. Challenges without qualifiers, however, did not elicit more replies than challenges with qualifiers. These findings suggest that qualifiers were used to hedge arguments, and such behaviors should be discouraged during initial stages of identifying arguments (more so in all-female than in all-male groups) in order to elicit more diverse and more opposing viewpoints needed to thoroughly and critically analyze arguments.

Keywords: Computer-mediated communication; CMC; communication style; group interaction patterns; interaction analysis; computer-supported collaborative learning; CSCL; collaborative argumentation

Introduction

Computer-mediated communication (CMC) is widely used to support student interaction in order to facilitate higher order learning through critical discussion. Collaborative argumentation is one activity used to foster critical discussion (Johnson and Johnson, 1992) in both face-to-face and online environments. Argumentation involves the process of building arguments to support a position, considering and weighing evidence and counter-evidence, and testing out uncertainties to extract meaning, achieve understanding (McAlister, 2003), and examine complex problems (Cho and Jonassen, 2002). Computer-supported collaborative argumentation (CSCA) provides students the opportunity to practice argumentation through writing and discussion simultaneously while communicating with text-based communication tools (Baker, 1999).

Various strategies have been developed to support collaborative argumentation where constraints are imposed on the types of messages students can post to a discussion. For example, Jeong and Juong (*in press*) presented to students a fixed set of message categories (arguments, challenges, supporting evidence, explanations) and required students to classify and label each message by

inserting a tag corresponding to a given message category in the subject headings of each message prior to posting them to threaded discussions in *Blackboard*, a course management system. Using a more formalized approach, Jonassen and Remidez (2002) developed a threaded discussion tool called *ShadowPDforum* where the message constraints are embedded and built into the computer interface so that students are required to select (from a menu of options) and classify the function of each message before messages are posted to discussions. This particular approach has been implemented in other asynchronous discussion environments like *ACT* (Duffy, Dueber and Hawley, 1998; Sloffer, Dueber and Duffy, 1999), *FLE3* (Leinonen, Virtanen, and Hakkarainen, 2002), *NegotiationTool* (Beers, Boshuizen, and Kirschner, 2004), and also in synchronous internet chat tools like *AcademicTalk* (McAlister, 2003).

Few if any studies, however, provide conclusive evidence to show that message constraints improve students' performance in collaborative argumentation and learning outcomes. Message constraints (or "social scripts") have been found to elicit more replies that elaborate on previous ideas, and produce greater gains in individual acquisition of knowledge (Weinberger, Ertl, Fischer, and Mandl, 2005). In another study, message constraints generated fewer unsupported claims and achieved greater knowledge of the argumentation process (Stegmann, Weinberger, Fischer, and Mandl, 2004). No differences were found, however, in individual knowledge acquisition, students' ability to apply relevant information and specific domain content to arguments, and ability to converge towards a shared consensus. Furthermore, message constraints were found to inhibit collaborative argumentation – producing fewer challenges per argument than argumentation without message constraints (Jeong and Juong, 2005).

These mixed findings suggest that students may require additional forms of guidance beyond what is offered with the use of message constraints. Message constraints provides guidance on "what" types of messages to contribute to discussions, but provides no guidance on "how" best to present one's ideas in ways that foster rather than inhibit critical discussion. Given the contentious nature of argumentation, managing the exchange of opposing viewpoints can be challenging in CMC because many students (in one case, 50 percent or more) prefer not to share ideas on controversial topics in CMC (Austin, 1997) and because non-verbal cues are absent in online discussions (Walther, 1992). Anywhere from 50-70 percent of face-to-face communication is conducted through non-verbal cues (Mehrabian, 1968). Nonverbal cues like crossing of arms, rigid posture, hesitations, and averting eye contact are useful for determining how best to manage confrontations. In addition, vocal pleasantness, physical proximity, and facial expressiveness have been found to be positively associated with judgments of communicator competence and persuasiveness (Burgoon, Birk, and Pfau, 1990). To compensate for the absence of non-verbal cues in CMC, students may need additional guidance on what linguistic forms to use or not to use when presenting arguments in order to foster both meaningful and critical exchanges between discussion participants.

Linguistic forms that are likely to play a role in how students engage in argumentation are linguistic qualifiers and intensifiers. Previous research on these two linguistic forms has been examined in online group discussions (Blum, 1999; Fahy, 2002a, 2002b, 2003; Herring, 1993, 1996; Savicki, Kelly, and Ammon, 2002). Previous studies show that females use more qualifiers than males, and that males use more intensifiers than females (Fahy, 2002a, 2002b). Fahy (2002b) found that females produced 57 percent of the most commonly used qualifiers (e.g., but, if, may, I think, often, probably, though) in instructor-moderated online discussions. The largest difference was in the use of "I think", where 68 percent of the total uses were by females. In contrast, males produced 61 percent of the most commonly used intensifiers (e.g., very, only, every, never, always), with males using "very" almost twice as often as females. Furthermore, females used qualifiers 3.6 times more often than intensifiers, while men used qualifiers 1.7 times more often than intensifiers. Previous studies also show that participants that use qualifiers tend to be

perceived as less persuasive and less credible (Hosman, 1989), particularly more so for females than males (Bradley, 1981). All together, these findings suggest that when qualifiers are used to present arguments, such arguments may be more likely to elicit replies, or more specifically, elicit challenges that question the merits of the argument than those presented without qualifiers. Yet at the same time, qualifiers can serve as hedges to deflect responses from potential challengers.

At this time, no reported studies have examined how students, male or female, in online discussions respond to other participants' messages when the ideas are presented with linguistic qualifiers and intensifiers. Studies are needed to examine: (a) how qualifiers and intensifiers, when used to present arguments and challenges, affect the number of elicited replies; and (b) to what extent do they elicit the types of replies most likely to increase the level of discussion and critical analysis of arguments. These types of questions must be examined in order to understand the strategic value of using various linguistic forms to encourage interaction and engage participants in the processes of verifying (e.g., argument → challenge → evidence) and justifying (e.g., argument → challenge → explain) arguments to improve collaborative work, decision-making, and problem solving in CMC.

Theoretical Assumptions

The nature of the collaborative task, the research questions, and methods used in this study are grounded under the assumptions of the dialogic theory of language (Bakhtin, 1981; Koschmann, 1999). The theory's main assumption is that social meaning is re-negotiated and constructed as a direct result of conflict produced in social interactions, and that conflict is the primary force that drives critical inquiry and dialog. The second assumption is that *conflict* is produced not by the utterance itself, but by the juxtaposition of inter-locking pairs of utterances. As a result, the need to explain, justify, and understand is felt and acted upon only when conflicts or errors are brought to attention (Baker, 1999). Supporting these assumptions are the findings from extensive research on collaborative learning in the face-to-face classroom (Johnson and Johnson, 1992; Wiley and Voss, 1999) and some recent research in CMC (Jeong, 2004b; Lemus, Seibold, Flanagan, and Metzger, 2004) that show conflict (produced by responses that challenge arguments) and the consideration of both sides of an issue is what drives inquiry, reflection, articulation of individual viewpoints and assumptions, and deeper understanding.

Purpose

This study explored how linguistic qualifiers and intensifiers affect the way messages and replies are exchanged when students engage in collaborative argumentation in asynchronous threaded discussions. This study examined four questions:

1. Does linguistic form affect the mean number of replies elicited by arguments and do the differences vary by the gender of the participant posting the argument?
2. Does linguistic form affect the number of replies elicited by challenges and do the differences vary by the gender of the participant posting the challenge?
3. Does the type of linguistic form used to present an argument produce different response patterns, and to what extent do the observed patterns lead to higher levels of critical analysis?
4. Does the type of linguistic form used to present a challenge produce different response patterns, and to what extent do the observed patterns lead to higher levels of critical analysis?

Method

Participants

The participants were graduate students ($n = 32$) from a major university in the Southeast region of the United States, with ages ranging from 20 to 50 years old. Participants were enrolled in a 16-week online graduate introductory course on distance education. Seventeen of these participants (11 females, 6 males) were enrolled in the course during the fall term. The remaining 15 participants were enrolled in the same course in the following term (11 females, 4 males).

Debate procedures

The students in the fall term participated in five debates, and students in the spring term participated in three debates. In both courses, students used threaded discussion forums in *Blackboard*, a Web-based course management system. Furthermore, the online debates in both courses were identically structured. Student participation in the debates and other discussions throughout the course contributed to 20 percent of the course grade. For each debate, students were required to post at least four messages. Prior to each debate, students were randomly assigned to one of two teams (balanced by gender) to either support or oppose a given position. Finally, students were required to vote on the team that presented the strongest arguments following each debate. In all the debates, the instructor did not participate in the debates, but on rare occasions, the instructor posted messages to ensure that students followed the rules and protocols.

In both iterations of the course, the total number of students and the male-to-female ratio were quite similar. The only notable difference between the two iterations is that the number of debates in the spring term was reduced from five debates to three debates to respond to students' who felt that five debates was too many within a single course. As a result, the students in the spring term participated in two fewer debates. The three remaining debates used in both iterations addressed the same topics and issues. The purpose of each debate was to critically examine design issues, concepts and principles in distance learning examined in the course. For example, students debated the following claims: "The Dick and Carey ISD model is an effective model for designing materials for online courses," "The role of the instructor should change when teaching at a distance," and "Type of media does not make any significant contribution to student learning."

Online debate messages and message labels

Students were presented a list of four message categories (see Figure 1) during the debates to encourage students to support and refute arguments with supporting evidence, explanations, and critiques. Based on Toulmin's (1958) model of argumentation, the response categories and their definitions were presented to students prior to each debate. Each student was required to classify each posted message by category by inserting the corresponding label into the subject headings of each message, and restrict the content of their messages to address one, and only one, category at a time. The investigator occasionally checked the message labels to determine if students were appropriately labeling their messages according to the described procedures. No participation points were awarded for a debate when students failed to follow these procedures. Students were able to return to previous messages to correct any errors in the message labels.

Figure 1. Example instructions on how to label messages during the online debates

Symbol	Description of symbol
+	Identifies a message posted by a student assigned to the team <u>supporting</u> the given claim/statement
-	Identifies a message posted by a student assigned to the team <u>opposing</u> the given claim/statement
ARG#	Identifies a message that presents <u>one and only one</u> argument or reason for using or not using chats (instead of threaded discussion forums). Number each posted argument by counting the number of arguments already presented by your team. Sub-arguments need not be numbered. ARG = "argument".
EXPL	Identifies a reply/message that provides additional support, explanation, clarification, elaboration of an argument or challenge.
BUT	Identifies a reply/message that questions or challenges the merits, logic, relevancy, validity, accuracy or plausibility of a presented argument (ARG) or challenge (BUT).
EVD	Identifies a reply/message that provides proof or evidence to establish the validity of an argument or challenge.

Students also identified each message by team membership by adding an “-” for opposing or a “+” for supporting team to the message labels (e.g., +ARG, -ARG). These tags enabled students to easily locate exchanges between members from opposing teams (e.g., +ARG → -BUT) and respond to the exchanges to advance their team’s position. An example is illustrated in Figure 2.

The purpose of assigning messages to specific functions was to make the links between messages explicit, thus enabling students to visualize the structure of their arguments (Jeong and Juong, *in press*). The labels also enabled the investigator to establish each message as a unit of analysis so that message-response sequences could be clearly identified to determine their relative frequencies. Previous studies in CMC were unable to successfully measure message-response sequences (Gunawardena, Lowe, and Anderson, 1997; Newman, Johnson, Cochrane, and Webb, 1996; Levin, Kim, and Riel, 1990; Rourke, Anderson, Garrison, and Archer, 2001) because messages often addressed multiple functions at the same time. As a result, mapping the relationships between messages and replies was a difficult, if not impossible, task. In this study, message labeling was found to be an effective solution to resolving some of the problems in establishing the unit of analysis. Although these procedures may appear to be artificial and perhaps intrusive, this method has been implemented in a number of computer-supported collaborative argumentation (CSCA) systems to facilitate argumentation and problem solving (Carr and Anderson, 2001; Cho and Jonassen, 2002; Duffy, Dueber, and Hawley, 1998; Jonassen and Remidez, 2002; McAlister, 2003; Sloffer, Dueber, and Duffy, 1999; Veerman, Andriessen, and Kanselaar, 1999).

Figure 2. Example of online debate with labeled messages

<input type="checkbox"/>	<input type="checkbox"/>	<u>SUPPORT statement because...</u>	Student names	Sat Oct 2, 2004 11:18 am
<input type="checkbox"/>	<input type="checkbox"/>	<u>+ARG#1 MedialsButAMereVehicle</u>	Student names	Mon Oct 4, 2004 8:47 pm
<input type="checkbox"/>	<input type="checkbox"/>	<u>-EVID MedialsButAMereVeh...</u>	Student names	Tue Oct 5, 2004 7:09 pm
<input type="checkbox"/>	<input type="checkbox"/>	<u>+But RelativityTheory...</u>	Student names	Tue Oct 5, 2004 9:43 pm
<input type="checkbox"/>	<input type="checkbox"/>	<u>-But RelativityThe...</u>	Student names	Sat Oct 9, 2004 10:12 am
<input type="checkbox"/>	<input type="checkbox"/>	<u>-BUT Whataboutemotions?</u>	Student names	Tue Oct 5, 2004 9:53 pm
<input type="checkbox"/>	<input type="checkbox"/>	<u>+EVID DistEdEffectiveAsF2F</u>	Student names	Tue Oct 5, 2004 10:40 pm
<input type="checkbox"/>	<input type="checkbox"/>	<u>-BUTMediaamerevehicle</u>	Student names	Wed Oct 6, 2004 8:19 pm
<input type="checkbox"/>	<input type="checkbox"/>	<u>+EVID MooreConcurs</u>	Student names	Wed Oct 6, 2004 10:07 pm
<input type="checkbox"/>	<input type="checkbox"/>	<u>+EXPLMediaSelectionCo...</u>	Student names	Sun Oct 10, 2004 12:35 am
<input type="checkbox"/>	<input type="checkbox"/>	<u>-BUT WellChosenEffect...</u>	Student names	Sun Oct 10, 2004 4:31 pm
<input type="checkbox"/>	<input type="checkbox"/>	<u>+But SupportingRes...</u>	Student names	Sun Oct 10, 2004 5:37 pm
<input type="checkbox"/>	<input type="checkbox"/>	<u>-BUTMediaismorethanamere...</u>	Student names	Fri Oct 8, 2004 5:30 pm
<input type="checkbox"/>	<input type="checkbox"/>	<u>+BUT SupportingEviden...</u>	Student names	Sat Oct 9, 2004 8:51 am
<input type="checkbox"/>	<input type="checkbox"/>	<u>-BUT LearningNotSimplyAP...</u>	Student names	Mon Oct 11, 2004 9:54 am
<input type="checkbox"/>	<input type="checkbox"/>	<u>+ARG2 Standards for teaching</u>	Student names	Wed Oct 6, 2004 1:48 pm
<input type="checkbox"/>	<input type="checkbox"/>	<u>+But Clarification?</u>	Student names	Sun Oct 10, 2004 5:39 pm
<input type="checkbox"/>	<input type="checkbox"/>	<u>+ARG3 MediaUnrelatedtoLearn...</u>	Student names	Wed Oct 6, 2004 3:12 pm
<input type="checkbox"/>	<input type="checkbox"/>	<u>-BUTMediaUnrelatedtoLearn...</u>	Student names	Wed Oct 6, 2004 8:26 pm
<input type="checkbox"/>	<input type="checkbox"/>	<u>+BUT MediaSelection</u>	Student names	Thu Oct 7, 2004 9:20 am
<input type="checkbox"/>	<input type="checkbox"/>	<u>-BUT MediaSelection</u>	Student names	Sun Oct 10, 2004 11:21 am
<input type="checkbox"/>	<input type="checkbox"/>	<u>+EVID MethodNotMedia</u>	Student names	Wed Oct 6, 2004 11:04 pm
<input type="checkbox"/>	<input type="checkbox"/>	<u>-BUT MediaUnrelatedtoLea...</u>	Student names	Sat Oct 9, 2004 10:59 am

Data preparation

Computer software was written by the investigator to download and compile messages from *Blackboard* discussion forums into *Microsoft Excel*. The codes assigned to each message by the students were automatically pulled from the subject headings to identify each message an argument (ARG), evidence (EVID), challenge (BUT), or explanation (EXPL). The seven most commonly used qualifiers (“but”, “if”, “may/ might”, “I think”, “often”, “probably”, and “though”) identified by Fahy (2002b) were used to assign messages to the qualifiers group. The five most commonly used intensifiers (“very”, “only”, “every”, “never”, and “always”) were used to assign messages to the intensifiers group.

Table 1 shows the frequencies of each indicator observed in this study and in Fahy’s study. The presence of any of the select indicators found within the message text determined which messages were assigned to which linguistic group. As a result, messages were coded into four groups – (1) messages with qualifiers, (2) with intensifiers, (3) messages with neither, and (4) messages with both qualifiers and intensifiers. Tables 2 and 3 shows the mean number of replies elicited by arguments and challenges, respectively, presented by group and gender.

Inter-rater reliability

One debate from each course was randomly selected and coded by the investigator to test for errors in students’ message labels. Overall percent agreement was .91 based on the analysis of codes assigned to 158 messages consisting of 42 arguments, 17 supporting evidence, 81 critiques, and 17 explanations. The Cohen Kappa coefficient, which accounts for chance in coding errors based on the number of categories in the coding scheme, was .86 – indicating excellent inter-rater

reliability given that Kappa values of .40 to .60 is considered fair, .60 to .75 as good, and over .75 as excellent (Bakeman and Gottman, 1997, p. 66).

Table 1. Frequency of qualifiers and intensifiers observed in study

	Words	<i>n</i>	#Msgs	%Msgs	%	Fahy%
Qualifiers	But	308	242	31%	37%	34%
	If	206	167	21%	25%	23%
	May/might	180	145	18%	22%	12%
	I think	45	41	5%	5%	12%
	Often	20	17	2%	2%	9%
	Probably	8	8	1%	1%	5%
	Though	68	64	8%	8%	5%
		835	453	58%	74%	
Intensifiers	Very	72	67	9%	25%	37%
	Only	128	110	14%	45%	26%
	Every	43	38	5%	15%	22%
	Never	16	13	2%	6%	8%
	Always	28	26	3%	10%	8%
	Total	287	221	28%	26%	28%
		1122		786		

Note: Females used 43 percent more qualifiers per message ($M = 1.21$, $STD = 1.49$, $n = 470$) than males ($M = .84$, $STD = 1.04$, $n = 312$). Females used 22 percent more intensifiers per message ($M = .39$, $STD = .68$, $n = 469$) than males ($M = .32$, $STD = .62$, $n = 312$).

Table 2. Mean number of replies elicited by arguments presented by group and by gender

Group	Gender	<i>Mean</i>	<i>STD</i>	<i>n</i>
Qualifiers	Female	.86	1.06	29
	Male	1.50	1.34	18
	Total	1.11	1.20	47
Intensifiers	Female	1.00	.63	11
	Male	2.80	1.48	5
	Total	1.56	1.26	16
Neither	Female	1.89	1.33	44
	Male	1.89	1.11	38
	Total	1.89	1.23	82
Total	Female	1.42	1.26	84
	Male	1.85	1.24	61
	Total	1.60	1.27	145

Note: Based on messages posted by 22 females and 10 males

Table 3. Mean number of replies elicited by challenges presented by group and by gender

Group	Gender	Mean	STD	n
Qualifiers	Female	.44	.62	107
	Male	.66	.70	70
	Total	.53	.66	177
Intensifiers	Female	.61	.61	18
	Male	.85	.55	13
	Total	.71	.59	31
Neither	Female	.53	.75	59
	Male	.66	.77	61
	Total	.59	.76	120
Total	Female	.48	.66	184
	Male	.67	.72	144
	Total	.57	.69	328

Note: Based on messages posted by 22 females and 10 males

Statistical Analysis

A 3 (linguistic form) x 2 (gender) univariate analysis of variance was used to test for differences in the mean number of replies elicited per *argument* (the dependent variable) across two independent variables – linguistic form (qualifiers versus intensifiers versus neither) and gender (males versus females). The same analysis was used to test for differences in the mean number of replies elicited per *challenge*. Arguments and challenges containing *both* qualifiers and intensifiers were not tested because these messages often contained more qualifiers than intensifiers or vice versa, and thus, interpreting their precise effects would be problematic. The effects of messages presented with both qualifiers and intensifiers will be addressed separately in another study.

To test for differences in the *distribution and patterns in replies to arguments* presented with qualifiers, intensifiers, and neither, a three-sample Chi-square test of independence was used. Similarly, a three-sample Chi-square test of independence was used to test for differences in the distribution of replies to *challenges* presented with qualifiers, intensifiers, and neither. The purpose of these tests were to determine which particular linguistic forms were more likely to produce discourse patterns that are most likely to generate sequences of speech acts that produce higher levels of critical analysis (e.g., argument → challenge → explain).

Given the exploratory nature of this study, the experiment-wise error was set at alpha level $p = .10$. As a result, each of the four tests (two ANOVA and two Chi-square tests) were conducted at $p = .10 / 4 = .025$. Note that the frequency of male arguments with intensifiers was only $n = 5$ (see Table 2). Nevertheless, this data was included in the first ANOVA test because: (a) the overall trend in the differences in number of replies elicited by arguments between linguistic groups was consistent with the differences observed in the number of replies elicited by challenges, supporting evidence, and explanations between linguistic groups (see reply rates in Figure 3); and

(b) the investigator chose to take a more liberal approach in order to fully explore and identify issues for future study.

Figure 3. Transitional probability matrices produced by the Discussion Analysis Tool containing the response distributions for messages by category X group

Transitional probabilities for messages using qualifiers

	ARG	BUT	EVI	EXP	Replies	No Replies	Givens	Reply Rate
ARGq	.00	.67	.15	.17	52	19	47	.60
BUTq	.00	.80	.11	.09	95	100	177	.44
EVIq	.00	.85	.08	.08	13	28	37	.30
EXPq	.00	.75	.12	.12	16	15	29	.48
	0	134	21	21	176	160	290	.45

Transitional probabilities for messages using intensifiers

	ARG	BUT	EVI	EXP	Replies	No Replies	Givens	Reply Rate
ARGi	.00	.64	.20	.16	25	2	16	.87
BUTi	.00	.62	.21	.17	24	11	31	.65
EVIi	.00	.80	.00	.20	5	4	8	.50
EXPi	.00	.75	.00	.25	4	1	4	.75
	0	38	10	10	58	18	59	.69

Transitional probabilities for messages using neither qualifiers nor intensifiers

	ARG	BUT	EVI	EXP	Replies	No Replies	Givens	Reply Rate
ARGn	.01	.54	.30	.15	155	9	82	.89
BUTn	.00	.68	.14	.18	71	67	120	.44
EVI n	.00	.62	.14	.24	21	25	42	.40
EXPn	.00	.72	.17	.11	18	16	31	.48
	2	157	62	44	265	117	275	.56

Note: ARG = argument, BUT = challenge, EVI = supporting or counter evidence, EXP = explanation. For example, the top matrix shows that 67 percent of the 52 replies to ARGq were challenges (BUT). In contrast, the third matrix shows that 54 percent of the 155 replies to ARGn were challenges.

Results

Effects on number of elicited replies

Responses to arguments. The 3 (linguistic form) x 2 (gender) univariate analysis of variance revealed significant differences in the mean number of replies elicited by arguments presented with qualifiers versus intensifiers versus neither, $F(2, 139) = 5.41, p = .005$. Table 2 shows that the mean number of replies elicited per argument was 1.10 ($SD = 1.20, n = 47$) with qualifiers, 1.56 ($SD = 1.26, n = 16$) with intensifiers, and 1.89 ($SD = 1.22, n = 82$) with neither. The mean number of replies elicited with qualifiers was 29 percent below the mean number of replies elicited with intensifiers (effect size = -0.37), and 41 percent below the mean number of replies elicited with neither (effect size = -0.64). The mean number of replies elicited with intensifiers was 17 percent lower than the mean number of replies elicited with neither (effect size = -0.26).

Significant differences were found in the mean number of replies elicited per male versus female argument, $F(1, 139) = 9.83, p = .002$. Table 2 shows that the mean number of replies elicited per female and male argument was 1.41 ($SD = 1.26, n = 84$) and 1.85 ($SD = 1.23, n = 61$), respectively. As a result, the mean number of replies elicited per female argument was 24 percent lower than the mean number of replies elicited per male argument (effect size = -0.35).

The effects of linguistic form on the mean number of replies elicited per argument was found to significantly vary and interact with the gender of the participant posting the argument, $F(2, 139) = 3.70, p = .027$. The mean number of replies elicited per female argument was .86 ($SD = 1.06, n = 29$) with qualifiers, which increased to 1.0 ($SD = .63, n = 11$) with intensifiers, and increased yet again to 1.88 ($SD = 1.33, n = 44$) with neither. In contrast, the mean number of replies elicited per male argument was 1.5 ($SD = 1.34, n = 18$) with qualifiers, which increased to 2.8 ($SD = 1.48, n = 5$) with intensifiers, but then, dropped down to 1.89 ($SD = 1.11, n = 38$) with neither. Female arguments with qualifiers elicited 42 percent fewer replies than male arguments with qualifiers (effect size = -0.53). In contrast, female arguments with neither qualifiers nor intensifiers elicited an equal number of replies as male arguments with neither qualifiers nor intensifiers (effects size = -.00). These findings suggest that the effect of using qualifiers when presenting arguments is greatest when they are presented by females than by males. A possible factor that contributed to this finding was that females used more qualifiers ($M = 1.82, SD = 1.59, n = 29$) per argument than males ($M = 1.52, SD = .70, n = 18$).

A post-hoc test for differences in the mean number of challenges elicited per argument revealed no main effects between linguistic forms, $F(2, 139) = 1.09, p = .34$, and gender, $F(1, 139) = 2.71, p = .10$. However, the interaction between linguistic form and gender was significant, $F(2, 139) = 3.28, p = .04$. Hence, the effects of linguistic form on the number of challenges elicited per argument varied by the gender of the participant posting the argument. Table 4 shows that the mean number of challenges elicited per female argument was .59 ($SD = .73, n = 29$) with qualifiers, which increased to .73 ($SD = .65, n = 11$) with intensifiers, and increased yet again to 1.14 ($SD = 1.11, n = 44$) with neither. In contrast, the mean number of challenges elicited per male argument was 1.00 ($SD = 1.14, n = 18$) with qualifiers, which increased to 1.60 ($SD = 1.14, n = 5$) with intensifiers, but then, dropped down to .87 ($SD = .81, n = 38$) with neither. Female arguments with qualifiers elicited 41 percent fewer challenges than male arguments with qualifiers (effect size = -0.43). Female arguments with neither qualifiers nor intensifiers elicited 31 percent more challenges than male arguments with neither (effect size = +0.27).

Table 4. Mean number of challenges elicited by arguments presented by group and by gender

Group	Gender	Mean	STD	n
Qualifiers	Female	.59	.73	29
	Male	1.00	1.14	18
	Total	.74	.92	47
Intensifiers	Female	.73	.65	11
	Male	1.60	1.14	5
	Total	1.00	.89	16
Neither	Female	1.14	1.11	44
	Male	.87	.81	38
	Total	1.01	.99	82
Total	Female	.89	.97	84
	Male	.97	.95	61
	Total	.92	.96	145

Note: Based on messages posted by 22 females and 10 males

Responses to challenges

The 3 (linguistic form) x 2 (gender) univariate analysis of variance revealed no significant differences in the mean number of replies elicited per challenge with qualifiers, intensifiers, and neither, $F(2, 262) = .90, p = .41$. Table 3 shows that the mean number of replies elicited per challenge was .52 ($SD = .66, n = 177$) with qualifiers, .71 ($SD = .59, n = 31$) with intensifiers, and .59 ($SD = .76, n = 120$) with neither. The mean number of replies elicited per challenge with qualifiers was 26 percent below than the mean number of replies elicited with intensifiers (effect size = -0.29), and 11 percent below the mean number of replies elicited with neither (effect size = -0.09). The mean number of replies elicited per challenge with intensifiers was 20 percent greater than the mean number of replies elicited with neither (effect size = +0.17).

No significant differences were found in the mean number of replies elicited per male versus female challenge, $F(1, 262) = 3.79, p = .052$. The mean number of replies elicited per female and male challenge was .48 ($SD = .66, n = 184$) and .67 ($SD = .72, n = 144$), respectively. The mean number of replies elicited per female challenge was 28 percent lower than the number elicited per male challenge (effect size = -0.27).

No significant interaction was found between linguistic form and gender on the mean number of replies elicited per challenge, $F(2, 262) = .16, p = .85$. The effects of linguistic form did not depend on the gender of the participant that presented the challenges. The mean number of replies elicited per female challenge was .44 ($SD = .62, n = 107$) with qualifiers, .61 ($SD = .61, n = 18$) with intensifiers, and .52 ($SD = .75, n = 59$) with neither. In a similar pattern, the mean number of replies elicited per male challenge was .66 ($SD = .70, n = 70$) with qualifiers, which increased to .84 ($SD = .55, n = 13$) with intensifiers, but then, dropped to .66 ($SD = .77, n = 61$) with neither.

Figure 4. State diagrams of response patterns between message categories within groups

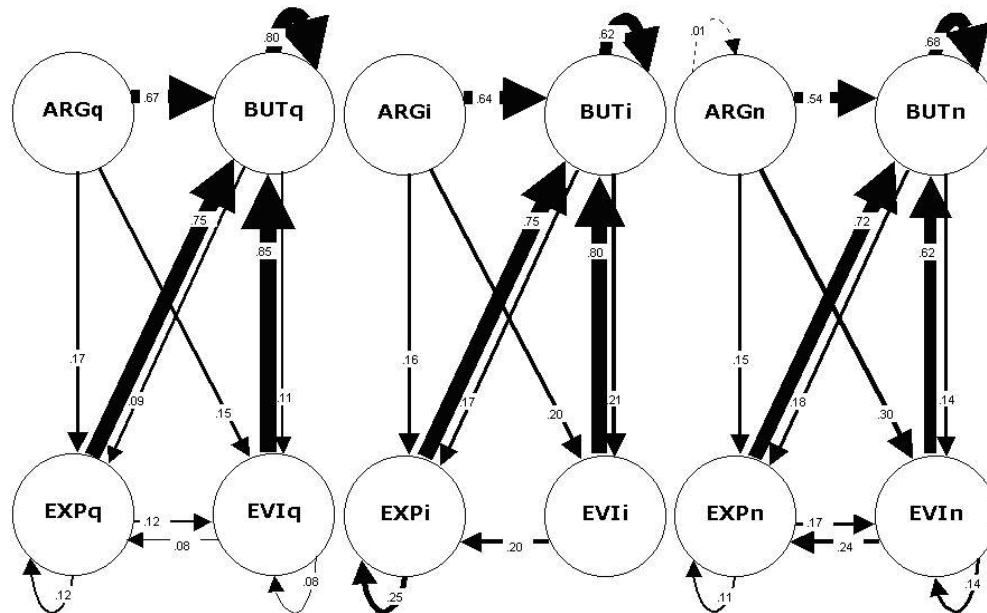

Note: ARG = argument, BUT = challenge, EVI = supporting or counter evidence, EXP = explanation. The line density reflects the transitional probabilities observed between each message pair shown in the transitional probability matrices in Figure 3. For example, the first diagram shows that 67 percent of all replies to qualified arguments were challenges, 15 percent were supporting evidence, and 17 percent were explanations.

The three matrices in Figure 3 reveal the response distributions elicited by each message category within each linguistic group. These distributions were computed using the Discussion Analysis Tool (Jeong, 2005), which tallied the frequencies and computed the relative frequencies for each observed message-response pair. The three-sample Chi-square tests revealed that differences in the response distribution elicited by: (a) ARGq versus ARGi versus ARGn were not statistically significant, $\chi(6) = 5.99, p = .42$; and (b) BUTq versus BUTi, versus BUTn were also not statistically significant, $\chi(4) = 5.4, p = .25$. The diagrams in Figure 4 are “state diagrams” (Bakeman and Gottman, 1997, p. 97) or “events networks” (Rothwell and Kazanas, 1998, p. 137) depicting the response distributions or “activity paths” triggered by each message category presented with qualifiers, intensifiers, and neither.

The diagrams suggest that qualifiers are more likely to produce (ARG → BUT) and (BUT → BUT) exchanges, and hence, more likely to produce (ARG → BUT → BUT) than messages without qualifiers. In contrast the diagrams also suggest the possibility that messages without qualifiers were more likely to produce BUT → EXPL. Therefore, messages without qualifiers may be more likely to produce sequences like ARG → BUT → EXPL that lead to deeper reflection and analysis of arguments. The data in this study, however, revealed that these response distributions or activity paths overall were not significantly different. As a result, one linguistic form did not necessarily produce response patterns that promoted more critical analysis than any other linguistic form.

Discussion

The purpose of this study was to explore the effects of linguistic qualifiers and intensifiers on how participants interacted and exchanged messages in online debates when using asynchronous threaded discussion forums. This study found that: (a) qualified arguments elicited significantly fewer replies (with moderate effect sizes) than arguments presented with intensifiers and neither; (b) the reduction in number of replies elicited by qualified arguments was greater when arguments were presented by females than males; and (c) the number of replies elicited by challenges with and without qualifiers was not significantly different. At the same time, however, this study also found no differences in the response patterns elicited by arguments and challenges between linguistic groups. Thus, no clear evidence was found to indicate that any one linguistic form, when used to present arguments and challenges, were more likely to trigger sequences of exchanges that promote more critical analysis of arguments than another linguistic form.

Fewer replies elicited by arguments

This study found that qualified arguments elicited fewer replies than arguments without qualifiers. One likely explanation for this finding is that the participants in this study used qualifiers primarily to hedge their claims in order to make their claims less vulnerable to criticism (given the competitive nature of the debates) in contrast to making their claims open for discussion. If qualifiers were used primarily to avoid conflict, then these findings are consistent with the Dialogic theory and its assumption that conflict (or the absence of conflict) is what drives (or inhibits) further inquiry and dialog (Bakhtin, 1981; Koschmann, 1999). Future studies, however, are needed to determine when qualifiers are used to hedge claims and when they are used to leave claims open for discussion, and how the effects of qualifiers differ when claims are presented in open exploratory discussions versus argumentative discussions.

Number of replies elicited by arguments can vary by gender

Female arguments elicited fewer replies than male arguments when presented with qualifiers. One possible explanation is that these differences may simply have been a product of the tendencies of females to engage in more supportive interactions combined with the tendencies of males to engage in more argumentative interactions with other participants (Fahy, 2002a). This could have been exacerbated by the way females in this study used 43 percent more qualifiers per message than males, thus making female arguments less likely than male arguments to elicit critical responses.

With intensifiers, the number of replies elicited by female arguments was also less than the number elicited by male arguments. One possible explanation for this finding is that the females might have been more cautious than males in using intensifiers and used them only when they felt that their argument had strong merits and hence were more difficult to refute. In contrast, the males might have used intensifiers more liberally and were more emphatic than the females when presenting both strong and weak arguments. As a result, the male arguments presented with intensifiers may have incited more criticism and thus elicited more replies.

In contrast, female arguments elicited a nearly equal number of replies as male arguments when they were stated factually (with neither qualifiers nor intensifiers). One possible explanation for this finding is that some females may have been perceived to be less credible than males simply based on their gender (Bradley, 1981). Thus, the absence of qualifiers or hedges in the female arguments made them more susceptible to challenges and questioning than male arguments

without qualifiers. All these explanations are purely speculative at this time, and will require further investigation.

No differences in number of replies elicited by challenges

In this study, no differences were found in the number of replies elicited by challenges presented with versus without qualifiers. One possible explanation for this finding is that qualifiers may have been used primarily to qualify an opposing argument (or to point out the conditions that limit the merits and plausibility of an argument), not to qualify the ideas or content presented in the challenge in itself. The other possible explanation is that the act of posting a challenge in reply to an argument initiated the conflict needed to drive further inquiry (based on the assumptions of the Dialogic theory), and that resulting drive compensated for the inhibiting effects of qualifiers (or decreases in number of replies elicited by qualified arguments).

Effects of linguistic form on response patterns and sequences

This study did not find clear evidence to indicate that any one linguistic form, when used to present arguments and challenges, were more likely to trigger response patterns and sequences of exchanges that lead to higher levels of critical analysis than another linguistic form. Nevertheless, the state diagrams generated in this study serve as useful tools for identifying and predicting potential areas where linguistic qualifiers and intensifiers could make a potential impact (when used in other contexts) on how participants interact and engage in critical discourse. One response pattern to examine more closely in future investigations is how the challenges stated with qualifiers appeared in this study to trigger a disproportionately high number of counter-challenges. What effect this level of contention has on eliciting subsequent replies, and how subsequent replies contribute to increased depth in critical analysis and discussion will require further investigation.

Instructional Implications

Overall, the findings in this study, although not conclusive, suggest that qualifiers were used primarily to hedge arguments in the online debates, and as a result, qualifiers tended to decrease the number of replies elicited by arguments. This finding suggests that the use of qualifiers should be discouraged during the initial stages of identifying arguments in order to: (a) avoid precluding others from sharing opposing viewpoints to challenge arguments; (b) elicit more diverse viewpoints and reactions; (c) support a more thorough analysis of arguments; and (d) maximize opportunities to achieve new insights and understanding. To some extent, this is similar to the rule often applied in group brainstorming where participants are asked to refrain from critiquing proposed arguments (including one's own claims) until all arguments are presented. The findings in this study suggest that implementing such a rule can lead to a substantial increase (with moderate effect sizes) in replies to arguments, and increases in level of critical analysis. The greatest gains might be achieved when this rule is applied in mostly female or all-female groups given the interaction between linguistic form and gender observed in this study.

Directions for Future Research

Once again, the findings in this study are not conclusive due to the exploratory nature of this investigation and due to particular situational variables surrounding the online debates. To conduct a closer examination of the findings reported in this study and to address some of the limitations of this study, future studies will need to: (a) examine a broader range of linguistic

phrases to better discriminate messages between linguistic groups; (b) analyze a larger sample of messages that use intensifiers; (c) identify the combination of words that can be used to discriminate when qualifiers are used to hedge claims from when they are used to leave claims open for discussion; (d) test the effects of qualifiers in the context of other group tasks and goals; (e) observe a larger number of discussion groups to prevent any idiosyncrasies in the social dynamics of any one group from potentially skewing the findings; (f) observe groups with different gender compositions and group size; and (g) examine the effects of linguistic qualifiers and intensifiers used in different contexts with and without message constraints.

In conclusion, this study provides a preliminary glimpse into the combined effects of message function, linguistic form, and gender on group interaction and group performance in CMC, and how particular patterns of interaction support critical discussions. The methods and tools described in this study will hopefully serve as a framework for investigating the effects of other communication styles and linguistic forms such as emoticons, humor, and rhetorical questions that can potentially affect both the form and function of messages and their ability to promote critical analysis, reflection, and the construction of shared meanings. Measuring the combined effects of message function and form will hopefully enable future researchers and instructional designers to develop more precise strategies for sequencing speech acts to optimize group performance in collaborative work, problem-solving, and learning in computer-mediated environments.

References

- Austin, R. (1997). Computer Conferencing: Discourse, education and conflict mediation. *Computers & Education*, 29(4), 153 – 161.
- Bakeman R., and Gottman, J. M. (1997). *Observing Interaction: An introduction to sequential analysis*. (2nd edition). University Press, Cambridge.
- Baker, M. (1999). Argumentation and constructive interaction. In P. Courier and J. E. B. Andriessen (Eds.) *Foundations of Argumentative Text Processing* (pp. 179-202). Amsterdam: Amsterdam University Press.
- Bakhtin, M. (1981). Discourse in the novel (M. Holquist & C. Emerson, Trans.) In M. Holquist (Ed.) *The Dialogic Imagination* (pp. 259-422). Austin, TX.: The University of Texas Press.
- Beers, P. J., Boshuizen, E., and Kirschner, P. (2004). Computer support for knowledge construction in collaborative learning environments. Paper presented at the *American Educational Research Association Conference 2004*, San Diego, CA.
- Blum, K. (1999). Gender Differences in Asynchronous Learning in Higher Education: Learning styles, participation barriers and communication patterns. *Journal of Asynchronous Learning Networks*, 3(1). 46 – 66.
- Bradley, P. H. (1981). The Fold-linguistics of Women's Speech: An empirical examination. *Communication Monographs*, 48, 73 – 90.
- Burgoon, J., Birk, T., and Pfau, M. (1990). Nonverbal behaviors, persuasion, and credibility. *Human Communication Research*, 17(1), 140 – 169.

- Carr, C., and Anderson, A. (2001). Computer-supported Collaborative Argumentation: Supporting problem-based learning in legal education. Paper presented at the *Computer Support for Collaborative Learning (CSCL) 2001 Conference*. Retrieved October 30, 2003 from: <http://www.mmi.unimaas.nl/euro-cscl/Papers/25.pdf>
- Cho, K., and Jonassen, D. (2002). The effects of argumentation scaffolds on argumentation and problem solving. *Educational Technology Research and Development*, 50 (3), 5 – 22. Retrieved March 3, 2004 from: <http://tiger.coe.missouri.edu/~jonassen/Argumentation.pdf>
- Duffy, T. M., Dueber, B., and Hawley, C. L. (1998). Critical Thinking in a Distributed Environment: A pedagogical base for the design of conferencing systems, In C. J. Bonk, and K. S. King (Eds.) *Electronic Collaborators: Learner-centered technologies for literacy, apprenticeship, and discourse* (51-78). Mahwah, NJ.: Erlbaum.
- Fahy, P. (2002a). Epistolary and Expository Interaction Patterns in a Computer Conference Transcript. *Journal of Distance Education*, 17(1), 20 – 35.
- Fahy, P. (2002b). Use of Linguistic Qualifiers and Intensifiers in Computer Conference. *The American Journal of Distance Education*, 16(1), 5 – 22.
- Fahy, P. (2003). Indicators of Support in Online Interaction. *International Review of Research in Open and Distance Learning*, 4(1). Retrieved April 21, 2004 from: <http://www.irrodl.org/content/v4.1/fahy.html>
- Gunawardena, C., Lowe, C., and Anderson, T. (1997). Analysis of Global Online Debate and the Development of an Interaction Analysis Model for Examining Social Construction of Knowledge in Computer Conferencing. *Journal of Educational Computing Research*, 17(4), 397 – 431.
- Herring, S. (1993). Gender and democracy in computer-mediated communication. *Electronic Journal of Communication*, 3(2). Retrieved August 22, 2001 from: <http://www.cios.org/www/ejc/v3n293.htm>
- Herring, S. (1996). Two variants of an electronic message schema. In S. Herring (Ed.) *Computer-Mediated Communication: Linguistic, social and cross-cultural perspectives*, (81-106). Amsterdam: John Benjamins.
- Hosman, L. (1989). The Evaluative Consequences of Hedges, Hesitations, and Intensifiers: Powerful and powerless speech styles. *Human Communication Research*, 15(3), 383 – 406.
- Jeong, A. (2003). The sequential analysis of group interaction and critical thinking in on-line threaded discussions. *The American Journal of Distance Education*, 17(1), 25 – 43.
- Jeong, A. (2004a). Methods and tools for the computational analysis of group interaction and argumentation in asynchronous online group discussions. Paper presented at the *2005 Learning Technology Symposium*, New York, NY. Retrieved August 1, 2005, from: <http://garnet.fsu.edu/~ajeong>

- Jeong, A. (2004b). The combined effects of response time and message content on growth patterns of discussion threads in computer-supported collaborative argumentation. *Journal of Distance Education*, 19(1), 36 – 53. Retrieved August 1, 2005 from: http://cade.athabasca.ca/vol19.1/JEONG_article.pdf
- Jeong, A. (2005). *Discussion Analysis Tool*. Retrieved May 10, 2005 from: <http://garnet.fsu.edu/~ajeong/DAT>
- Jeong, A., and Juong, S. (in press). The effects of response constraints and message labels on group interaction and argumentation in online discussions. *Computers & Education (in press)*.
- Johnson, D., and Johnson, R. (1992). *Creative Controversy: Intellectual challenge in the classroom*. Edina, MN.: Interaction Book Company.
- Jonassen, D., and Remidez, H. (2002). Mapping alternative discourse structures onto computer conference. Paper presented at the Paper presented at *Computer Support for Collaborative Learning 2002 Conference: Foundations for a CSCL Community*, Boulder, CO.
- Koschmann, T. (1999). Paradigm shifts and instructional technology: An introduction. In T. Koschmann (Ed.) *CSCL: Theory and practice of an emerging paradigm* (1-24). Mahwah, NJ.: Lawrence Erlbaum Associates.
- Leinonen, T., Virtanen, O., and Hakkarainen, K. (2002). Collaborative discovering of key ideas in knowledge building. In Proceedings of the *Computer Support for Collaborative Learning 2002 Conference*. Boulder, CO. Retrieved May 19, 2004 from: <http://fle3.uiah.fi>
- Lemus, D., Seibold, D., Flanagan, A., and Metzger, M. (2004). Argument and decision making in computer-mediated groups. *Journal of Communication*, 54(2), 302 – 320.
- Levin, J., Kim, H., and Riel, M. (1990). Analyzing instructional interactions on electronic message networks. In L. Harasim (Ed.) *Online Education*, (pp. 185-213), New York, NY.: Praeger.
- McAlister, S. (2003). *Assessing Good Argumentation*. Retrieved April, 10, 2004, from: <http://iet.open.ac.uk/pp/s.r.mcalister/personal/AssessingGEA.htm>
- Mehrabian, A. (1968). Communication without words. *Psychology Today* 2(9), 52 – 55.
- Newman, D., Johnson, C., Cochrane, C., and Webb, B. (1996). An Experiment in Group Learning Technology: Evaluating critical thinking in face-to-face and computer supported seminars. *Interpersonal Computing and Technology: An Electronic Journal for the 21st Century*, 4(1), 57 – 74.
- Rothwell, W., and Kazanas, H. C. (1998). *Mastering the instructional design process* (2nd edition). San Francisco: Jossey-Bass.
- Rourke, L., Anderson, T., Garrison, D. R., and Archer, W. (2001). Methodological issues in the content analysis of computer conference transcripts. *International Journal of Artificial Intelligence in Education*, 12, 8 – 22.

- Savicki, V., Kelley, M., and Ammon, B. (2002). Effects of training on computer-mediated communication in single or mixed gender small task groups. *Computers in Human Behavior*, 18(3), 257 – 269.
- Sloffer, S., Dueber, B., and Duffy, T. (1999). *Using Asynchronous Conferencing to Promote Critical Thinking: Two implementations in higher education*. Retrieved October 30, 2003 from: <http://crlt.indiana.edu/publications/crlt99-8.pdf>
- Stegmann, K., Weinberger, A., Fischer, F., and Mandl, H. (2004). Can computer-supported cooperation scripts facilitate argumentative knowledge construction? Paper presented at the *American Educational Research Association Conference*, San Diego, CA. Retrieved May 24, 2004 from: <http://home.emp.paed.uni-muenchen.de/~weinberg/download>
- Toulmin, S.E. (1958). *The Uses of Argument*. Cambridge: University Press.
- Veerman, A., Andriessen, J., and Kanselaar, G. (1999). Collaborative learning through computer-mediated argumentation. In C. M. Hoadley and J. Roschelle (Eds.), *Proceedings of the Computer Support for Collaborative Learning (CSCL) 1999 Conference* (640-650). Palo Alto, CA.: Stanford University. Available from Lawrence Erlbaum Associates, Mahwah, NJ.
- Walther, J. (1992). Interpersonal Effects in Computer-mediated Interaction. *Communication Research*, 19(1), 52 – 90.
- Weinberger, A., Ertl, B., Fischer, F., and Mandl, H. (2005). Epistemic and social scripts in computer-supported collaborative learning. *Instructional Science*, 33(1), 1 – 30.
- Wiley, J., and Voss, J. (1999). Constructing Arguments from Multiple Sources: Tasks that promote understanding and not just memory for text. *Journal of Educational Psychology*, 91(2), 301 – 311.



November – 2005

Book Review – Distance Education and Languages, Evolution and Change

Editors: Börje Holmberg, Monica Shelley and Cynthia White (2005). *Distance Education and Languages, Evolution and Change*. 342 pages, soft cover. Multilingual Matters: ISBN: 1 8535 9776 7

Reviewed by: Rashid Aderinoye, University of Ibadan, Nigeria

Distance Education and Languages, Evolution and Change edited by Börje Holmberg, Monica Shelley, and Cynthia White, comprises 18 robust chapters grouped into six parts: 1) Learner's Autonomy; 2) Learner's Perspectives and Support; 3) Development of Intercultural Competence; 4) Methodology and Course Design; 5) Learning Environments; and lastly 6) Language and Teacher Development. This book also has a very useful preface, which mirrors its purpose and focus.

Before launching into descriptions of each chapter, I found that Holmberg and his colleagues offer an excellent account of the practice of distance education, with particular emphasis paid to language (which, in some cultures, remains a dark horse). My only concern lay in its applicability to developing countries and the spirit of ODL. Power outages are common here in my country, Nigeria, as elsewhere in sub-Saharan Africa and other developing nations throughout the world. Perhaps the auspicious day will come that developing countries will be able to take full advantage of technologies described in this book? In any event, I found this book very useful and I was honored to have been given the opportunity to review such excellent work.

The first chapter, *Autonomy and the Distance Language Learner*, by Stella Hurd, launches us into an examination of autonomy and the distance language learner. Hurd's chapter (which I personally feel likens to a distance education encyclopedia) uses the Open University United Kingdom (OUHK) as platform. Starting with a conceptual analysis of autonomy, reflections on definitions, and overview of noted academics Hurd asserts that students do not learn in isolation, but instead through interactions with others – a process which students move through concrete experience, reflection, abstract conceptualization, and action. Hurd then poses some relevant questions: Is autonomy a pre-condition for successful language learning? Or is it a product or goal that emerges from learner's exposure to certain contextual influences in language? She examines these questions using the concept of autonomy, as pioneered by Holmberg (1983) and how it currently guides the practice of distance education in the OU from the perspectives of course development, student recruitment, material preparation, and learner's support. She also highlights the role of technology in promoting learner autonomy, particularly using Computer Mediated Communication (CMC). In conclusion, Hurd asserts that if distance language learners are to attain autonomy, they must be capable of learning how to learn, because autonomy requires insight, a positive attitude, capacity for reflection, the necessity of self-management, and ability to interact with others.

Linda Murphy's, *Critical Reflection and Autonomy*, explores a study of distance learners of French, German and Spanish via a pilot study done at the south region of UK Open University. The findings from this pilot revealed that language learners exercise a considerable degree of functional control in their learning. Murphy also offers us constructive advice: learners must be encouraged to enhance their capacities for reflection and self-direction; they should have an explicit framework available to guide their progress; and they must be given a clear rationale, encouragement, support, along with the opportunity to practice within the course materials.

Alex Ding's *Theoretical and Practical Issues in the Promotion of Collaborative Learner Autonomy in a Virtual Self-Access Centre* describes the integration of ICT to language courses. Building upon earlier scholars' work on facilitating language learning via the Internet, Ding touches upon the theory of collaborative autonomy based on inter-subjectivity (which provided the bases for the creation of Virtual Self-Access Centres). Ding defines the term 'inter-subjectivity collaborative autonomy,' as a version of autonomy that not only stresses the virtues of collaboration as a means of facilitating such autonomy, but that by necessity entails complex relationships of inter-dependence.

In the chapter, *Towards a Learner-based Theory of Distance Language Learning: The concept of the learner-context interface*, Cynthia White explores the evolution of distance education. First, she provides a theoretical background, including Holmberg's conversational theory (1986) Moore's transactional theory (1970), Peters' industrial theory (1967), and Garrison's collaborative control theory (1987). Though I personally found it difficult to understand White's rationale for omitting the Wedemeyer's theory of learner autonomy (1977), she did inform the construction of a learning environment in accordance with the needs, preferences and abilities of the learner, and in response to the affordance of the learning context. Ultimately, White concludes that because the teacher is physically far from the learner, students themselves also need to be responsible for the process.

Cristina Rosi-Sole's and Mike Truman's, *Feed Back in Distance Language Learning: Current practices and new directions* offers great advice for those of us involved teaching language at a distance. Here they explore the ramifications of integrating feedback to achieve learner autonomy. I personally believe this issue is very relevant, as many distance learning institutions – and most particularly in developing economies – often do not place high priority on 'assignment' as an effective means of making distance learners into continuing learners.

A Framework for Supporting Students Studying English via a Mixed-mode Delivery System, by Carisma Dreyer, Nwabisa Bangeni, and Charl Nel, echoes the centrality of student support services in any distance education provision. These authors lucidly corroborate the findings of their empirical study with a framework of student support services.

Monica Shelley's and Uwe Baumann's *Assessing Intercultural Competence Gain in a German Distance Learning Course for Adults*, use 'auftack,' an Open University German language course, to demonstrate how communication competence, cultural awareness, and inter-cultural competence are connected to successful foreign language teaching outcomes. Establishing relationship between these terms, the authors link each of these key terms to foreign language teaching, thus bringing out cultural elements that bring us beyond that of merely exchanging information.

Richard Fay's and Leah Davcheva's *Developing Professional Intercultural Communicative Competence: Reflections on distance learning programmes for language educators and translators/ interpreters in Bulgaria* share their experience of a British Council supported project conducted in collaboration with local curriculum teams in Bulgaria and distance learning

professionals at University of Manchester, UK. Presented is a rich array of concepts ranging from language in Bulgaria, to inter-cultural communication, to language education and trans-national issues. Readers should pay particular attention to figures in Fay's and Davcheva's chapter, for they are very helpful in understanding the authors' concepts.

In *Teaching Foreign Language Skills by Distance Education Methods: Some basic considerations*, Börje Holmberg shares his with us his rich background as an educational researcher deeply rooted in theory. Holmberg provides us with a rich conceptual analysis of issues that, I concur based on my own experiences teaching basic literacy and foreign languages, are central to our understanding of open and distance learning as related to fundamental language acquisition skills: reading, listening, speaking, and writing. Holmberg succinctly treats us to nuances of sentence formation, pronunciation, and the relevance and appropriateness of inclusion of students' mother tongue at particular phases of foreign language acquisition.

Cecilia Garrido's *Course Design for the Distance Learner of Spanish: More challenges than meet the eye* examines ethical considerations of course development in distance education settings. She highlights non-formal learners' attributes that must be considered when developing courses, including integration of culture in language curriculum and the role ICT can have in developing students' linguistic and inter-cultural competence. The author roots her presentation in an underlying open university philosophy. And although emphasis is primarily paid on student needs assessment, issues of cultural diversity, and the use of ICT and its management do receive adequate attention. Interestingly, this author is not comfortable with term 'pedagogical' because it does not lend itself well to the principles of adult and non-formal education (to which distance learning is most suitable). Instead, she embraces the term 'andragogy' because it focuses on student experience, interest, needs, and readiness to learn – all attributes which are paramount to any successful distance education programme.

In *Learner Autonomy and Course Management Software*, Donald Weasenfistle, Christine F. Meloni and Sigrun Biesenbach-Lucas revisit the concept of learner autonomy, but with a new twist. The new twist being the integration of Course Management Software (CMS) as a teaching process that allows instructors to organise and manage course materials and student records, whilst at the same time providing students the opportunity for communication and collaboration. Based on practical experiences gained at a local Internet café, the authors outline three major elements used to develop autonomy in distance language learners: 1) discussion; 2) titles; and 3) testing. These three features were then used in engaging students (in four different settings) as a means of exercising choice, and to use these processes to benefit from other's feedback, all without direct supervision. In short, the key issues raised in this chapter is the relevance of our having a solid understanding of ICT and CMS applications, and how such technology can be used to optimize teaching and learning processes. The authors also detail combinations of ICT with other learner support services, all within the overall aim of fostering of learner autonomy.

Vincenza Tudini's *Chatlines for Beginners: Negotiating conversation at a distance* shows us how users browse, communicate, and exchange of ideas using chatlines. Tudini applied chatline technology to distance learning settings, using it as a tool for students to negotiate language acquisition skills. Indeed, it is well understood that students taught foreign languages in classroom-based settings, particularly during language laboratories, allow them the opportunity to practice speaking. On the other hand, learning 'how to speak' is clearly a major hurdle that nearly all distance foreign language learners face. Tudini describes a study conducted by the University of South Australia, which used chatlines to engage students in oral language development. I personally opine that researchers and teachers in developing countries can learn from reading this Australian experience. It is excellent!

In *Making Online Students Connect: Ethnographic strategies for developing online learning experiences*, Andreas Schramm explores differences between on campus and Web-based courses. Using an ethnographic strategy, Schramm details what is needed to transform a traditional on campus ESC teacher education to a Web-based course. The challenge explored is how, exactly, do interactive classroom-centred learners transfer their experiences to Web-based courses? Highlighted are the various modes of interaction. Schramm concludes that the use of ethnographic analysis of the communicative components can facilitate the transfer of traditional classroom interaction to an interactive online format.

John Milton in *Parrots to Puppet Masters: Fostering creative and authentic language use with online tools* questions findings from an earlier study that concluded that graduates from South East Asian classrooms tend to have little faculty of spoken English. Working with a team of students and targeting oral fluency as an outcome, Milton focused his efforts on the use of online language learning tools, with particular focus paid to the provision of feedback and student writing. Milton shows us that advances in Internet technology can be exploited to deliver principled and practical language instruction to foreign language students.

In *The Challenges of Implementing Online Tuition in Distance Language Courses: Task design and tutor role* Mirjam Hauck and Regine Hampel examine the Collaborative Virtual Learning Environment (CVLE) Lyceum. These authors report on a pilot study conducted at the Open University UK using Lyceum, which ultimately resulted in a successful online German language course. Both learners and tutors reported that the CVLE yielded very rewarding learning outcomes, wherein tutors are not only instructors but also facilitators and participants in the learning process, and students not only interact with tutors but with fellow students. The chapter ends on a note of sage advice that echo early Greek philosophers who built the original Lyceum in ancient Athens: we must all strive to create opportunities for students to engage in oral interaction, and the use of this modern-day Lyceum is one such viable forum.

In *Closing the Distance: Compensatory strategies in distance language education*, Heidi Hansson and Elizabeth Wenno, present a study that was designed to analyze methods of bridging the gap between learners and tutors, and between learners and learners. Hausson and Wenno echo earlier findings of Wedemeyer (1981) that distance learners are just as capable of learning as their traditional on-campus counterparts when communication media are fully integrated. They caution, however, that this will only happen if online learning environments are conducive, and learners and tutors are prepared to participate. In a nutshell, Hausson and Wenno outline what is needed to conduct successful distance language courses. Above all, they remind us that factors responsible for student success, are those that compensate for deficiencies typical of a distance course.

In *PLEASE*, which stands for Primary Language Teacher Education Autonomy and Self-Evaluation, Franca Poppi, Lesley Low, and Marina Bondi examine a three-year project designed to address the training needs of primary level, foreign language teachers. The purpose of PLEASE was to empower teachers with skills for autonomous learning and reflective thinking. The authors elaborate, step-by-step, on the PLEASE website project, starting with its rationale, features of autonomous learning environments, website design, interactive sections, and forms of support for computer mediated conferencing (CMC). In sum, the authors have developed an online device that they feel will meet the needs of teachers who are operating in numerous and varied contexts.

Do Coyle in *Exploring Zones of Interactivity in Foreign Language and Bilingual Teacher Education*, reports on a pilot, Teaching and Learning Observatory (TLO) at the University of Nottingham. As an initiative of the National Ministry of Education, the TLO was developed to

enhance a pre-and in-service professional development opportunities aimed to enhance the skills of foreign language and bilingual teachers. Coyle details TLO project's vision, along with the outcomes of a survey conducted to measure its effect. She touches upon the TLO activities, and costs and constraints of the TLO centers, and explores scenarios wherein ICTs are used for true enquiry rather than as a mere substitute for 'teacher talk.'

In conclusion, I feel that Holmberg and colleagues have written a fine compendium of distance education in relation to language teaching. This book's authors truly stand upon the shoulders of pioneers, such as Charles Toussaint and Gaster Langehscheidt (Titmus, 1981) who began what is generally recognised as the first formally organised foreign language correspondence school. While the Toussaint-Langensheidt School officially closed in 1936, Holmberg and colleagues have admirably continued the pioneering spirit of Toussaint's and Langehscheidt's work. Their book builds upon our insights and add context to the technological and theoretical advances being made in the field of open and distance learning. These authors show us that we can take foreign language studies to new heights using ICT and related technologies.

My only reservation, however, remains grounded within my context as a DE scholar working in sub-Saharan Africa. In the developing world, most students often do not enjoy ready access to fundamentals such as power supplies and bandwidth, let alone ready access to personal computers and affordable computing facilities. Clearly, with full integration of ICT on the horizon, distance educators in the developed world are now in the enviable position of helping students to help themselves. Holmberg and colleagues have proved beyond reasonable doubt that when and where ICT is functionally engaged (clearly, without any power interruptions typical of developing countries), CMC can and does bridge the gap between students and tutors. But can such technologies bridge the digital divide? Or will such technology only serve to widen it?

References

- Ackerman, P. L. (1996). A Theory of Adult Intellectual Development: process, personality, interests, and knowledge. *Intelligence*, 22, 229 – 259.
- Holmberg B.(1983). Guided Didactic Conversation in Distance Education in D. Seward (Eds.) *Distance Education: International Perspective*. (p. 114-122). London UK.: Groom Helm.
- Titmus, C. T (1989). *Lifelong Education for Adults: An International Handbook*. Oxford, UK.: Pergamon Press.
- Wedemeyer. C.A. (1977). Independent Study. In A.S. Knowles (Ed.) *The International Encyclopedia of Higher Education* (p. 2114-2132). Boston MA.: CIHED.
- Wedemeyer, C. A. (1981). *Learning at the Backdoor: reflections on non-traditional learning in the lifespan*. Madison, WI.: University of Wisconsin Press.



November – 2005

Book Review – Technology, e-learning and distance education (2nd edition)

Author: A. W. (Tony) Bates. (2004). *Technology, e-learning and distance education (2nd edition)*. RoutledgeFalmer Studies in Distance Education Series. 246 pages, softcover. London. ISBN: 0 4152 8437 6

Reviewed by: Heather Kanuka, Canada Research Chair in e-Learning and Associate Professor, Athabasca University – Canada's Open University

Technology, E-Learning and Distance Education aims to be the “essential guide for anyone wanting advice on how to choose the right technology at the right cost for a course or flexible learning program” (p. i). Building on the previous edition (*Technology, Open Learning and Distance Education* published in 1995 – which was prior to the ubiquitous use of the World Wide Web), this book offers new chapters which provide an overview of the developments in distance education and e-learning in the past decade (Chapter 1), two additional chapters on Web-based learning (Chapters 7 and 8), and two on synchronous conferencing technologies (Chapter 9 and 10) – which are co-edited with Janice Picard.

The remaining chapters on selecting technologies are basically unchanged from the first edition. Justification for the unchanged chapters by Bates is explained as a: “[resistance to] the post-modernist tendency to believe that everything new is good and there are no lessons to be learned from the past” (p. ix). Evidence of this conviction by Bates (with an obvious misunderstanding of post-modernism) can be seen throughout many of the unchanged chapters – which provide references 20+ years old and a corresponding absence of recent references to determine whether there continues to be stability within the research results in these areas.

The intended audience for this book is decision makers in education and training, as well as experienced distance education practitioners. Examples of those for whom the book will be of value includes: school superintendents, Deans of Humanities, World Bank teams, university Vice-Chancellors, College department heads, State Commissioners for Higher Education—even politicians and civil servants are listed as target audiences for this book. In the first Chapter, Bates promises the readers that this book will provide readers with information on (p. 3):

- What distance education is
- How it differs from e-learning
- How to select and use different technologies in relation to educational goals and local circumstances
- How readers can protect themselves and their organizations from vendors
- Some of the barriers to technology adoption

- How to remove some of the adoption barriers
- How to deal with rapid technological change and have a clear vision of how to deliver quality education and training to remote learners.

Does this book deliver on these claims?

Chapter 1 provides an overview on emerging trends in distance education and e-learning. As promised, definitions on distance education, as well as open learning and flexible learning have been provided. These definitions are based on Bates's opinion of what these concepts mean. As a basic book on technology, e-learning, and distance education, a richer discussion could have been provided for the reader by acknowledging that there is a general non-consensus on many of these definitions within the field of distance education, and other prominent distance educators may define distance education in different ways.

Chapter 2 provides an excellent overview of distance education organizations, and 'who is doing what.' This chapter is particularly well constructed in respect to providing an international perspective of current distance education organizations and the impact that technology has had on these organizations.

Chapter 3 provides an overview of the technological explosion in the field of distance education and how to select and use these technologies. The first part of this chapter is limited in value because of the way the discussion of technologies has been framed within media used prior to 1980. Though, the classification schemes provided are useful in understanding the relationships between media, technology and applications. The ACTION framework, also described in this chapter, has not been updated from the first edition and it is my opinion that there is no need to update it (in agreement with Bates) as the basic principles of using and choosing technology remains the same. Perhaps more importantly, the ACTION framework continues to be a useful guide for technology and media selection for distance education.

Chapters 4, 5 and 6 provide an overview of older distance education technologies: print, television and radio, as well as audio/ video cassettes and compact disk players. While many of these older distance education technologies are not currently in widespread use within North America, they continue to be widely used in other distance education institutions in other parts of the world. These chapters are comprehensive and provide useful frameworks for informed decision-making regarding older distance education technology characteristics. However, the data provided on costs are so seriously out of date there is little, if any, credibility for the advice given in regard to making decisions based on the cost analysis provided.

Chapters 7, 8, 9 and 10 provide an overview of newer distance education technologies, such as Internet conferencing tools (i.e., Web-based learning, and synchronous Internet audio and video communication tools). These chapters have a good balance between the advantages and disadvantages with some good, basic, common sense advice and a particularly good critical review of much of the 'online rhetoric'. This being said, there are some difficulties with these chapters as well. In chapter 7, for example, there is no description provided for 'Web-based learning' (also not defined in the first chapter) and the differences in cost and organization between Web-based learning with learning management tools versus customized institutional development have not been delineated and discussed. Moreover, much of the literature used to support the chapter on audio and video conferencing is a decade or more old. In addition there are many opinions made about effectiveness with no supporting references. There was also information on audio and video conferencing where I found myself asking "who cares?" For example, do administrators need to know about Bell Telephone Laboratories in the 1920s? That

decoding equipment is called codecs? That a full-motion analogue television picture changes 30 times per second in North America and 25 seconds per minute in Europe? That two operating lines in tandem are 58-64 kbs x 2 and six lines is 58-64 x 6, which equals 348-384 kbs? The important issues the readers need to know are the teaching and learning implications. And while there is a section on the implications for teaching and learning, it tells us what students and teachers can do, but tells us nothing on the implications of teaching and learning.

Chapter 11 provides a comprehensive, and concise, executive summary. Polonius' advice alone makes this chapter a worthwhile read!

Overall this book is a bare-bones resource and could be much improved with greater integration of the current research literature. Much of the book is drawn heavily on the author's experiences at the University of British Columbia, rather than an extensive review of the research. As such it is important to read this book with a critical perspective.

In the end, however, this book does deliver what it promises. And listed at \$53.50 (CDN) on Amazon.ca, it is also a reasonable price. Moreover, given Tony Bates' long and influential career in distance education he has earned the right to have his books placed on every distance educators' bookshelf.



November – 2005

Technical Evaluation Report

51. Text-based Conferencing: Features vs. functionality

Lynn Anderson and **Kathy McCarthy**
Masters of Distance Education Programme
Athabasca University – Canada's Open University

Abstract

This report examines three text-based conferencing products: *WowBB*, *Invision Power Board*, and *vBulletin*. Their selection was prompted by a feature-by-feature comparison of the same products on the *WowBB* website. The comparison chart painted a misleading impression of *WowBB*'s features in relation to the other two products; so the evaluation team undertook a more comprehensive and impartial comparison using the categories and criteria for online software evaluation developed by the American Society for Training and Development (ASTD). The findings are summarised in terms of the softwares' pricing, common features/ functions, and differentiating features.

Introduction

Asynchronous text-based conferencing, also known as bulletin boards, provides a flexible medium for online discussion and collaboration. It is also relatively inexpensive, as it does not require a high bandwidth or extra hardware. The licensing costs of individual products vary substantially, however. Text-based conferencing software can be attained as standalone products, or as a component of a larger software application such as a learning management system. Earlier reports in this series (reports #8, #43 and #44) have argued in favour of the flexibility provided by standalone components. Unnecessarily complex, integrated software packages are described by online students as 'bloatware,' providing more features than are actually needed.

Product Trials

The following evaluations use the ASTD software assessment criteria: see report # 7.

1. WowBB

This product markets itself as user-friendly and fully customisable forum software. It is privately owned and operated by Aycan Gulez, who is credited on the website for the design and programming. The evaluation is based on experiences with the trial software, and information on the product website.

Cost: see comparison table (see Appendix I).

Complexity: *WowBB* is a very user-friendly software, intuitive, and easy to navigate. At the time of the evaluation, the product had two sub-forums for customer support and product troubleshooting. The two forums were started in May of 2003, and by October 2005, the total of new topics started in them by customers was 1,838. This number is substantially smaller than on the help forums of the other two product websites.

Control: The board administrator has a wide range of controls, including the ability to filter unwanted words, and to ban users by IP or email address. The style editor allows changes to the appearance of the board via familiar controls such as sliders and checkboxes. The changes are previewed in real-time.

Clarity: The language used in both the bulletin board and the website is in clear, simple English. The layout of both is eye-catching, though somewhat unprofessional in appearance. Screen clutter is reduced by locating buttons and icons in pop-up menus.

Common Technical Framework: *WowBB* requires PHP 4.0.5 or higher, and MySQL 3.23 or higher. An Apache webserver (any version) is recommended, but any other webserver supporting PHP should work as efficiently. The product's WYSIWYG editor requires *Internet Explorer 5.5* or higher, or *Mozilla/ FireFox*. Users with other browsers see a standard text editor. *WowBB* can be integrated with a third-party chat-room called *SigmaChat*.

Notable Features:

- The integrated spell-checker highlights misspelled words and offers suggestions
- Employs a smart caching algorithm that speeds up response times by storing popular pages in a fast cache
- *WowBB* automatically detects the correct time-zone setting for the user
- Can transform many forum URLs to a format that even the most selective search engine will not decline. Requires an Apache webserver and an Apache module called 'mod_rewrite'
- Allows users to read new postings via email

Overall comments

WowBB lives up to its promise as a user-friendly and fully customisable forum software. In spite of all the features it offers, its best feature is its simplicity. This is evident in the website forums, where topics started by customers looking for assistance over the last three and a half years is low compared to the other two bulletin boards evaluated in this report. *WowBB*'s second advantage is that it is substantially less expensive than the other two products. However, the price information given on the product website is vague in relation to the likely price of future major upgrades to the software.

2. Invision Power Board

Invision Power Board is a product of *Invision Power Services* (IPS), a site and community-building services provider based in Virginia, USA. The evaluation is based on experiences with the trial software (v 2.0), information on the product website, and information from a sales representative contacted by 'phone.

Cost: see comparison table (see Appendix I).

Complexity: The *Invision Board* is cluttered, with too many options available at a time. It is not intuitive, and at times navigation is difficult. A user manual is available, though at an additional cost. The company website offers a client forum where users can get help from other users. This forum contains a large number of topics (7,905 as of October 2005) started by customers since September 2004.

Control: All passwords are encrypted when the user registers, and individual forums can be password-protected. Moderators can delete or redirect forums, and edit and delete topics while on the board. A personal control panel allows users a wide range of options for using the program. A message tracker allows tracking of any personal message sent on the board. This feature gives users the chance to delete any sent messages that have not yet been read by their intended recipient(s). Users may deny other members the ability to send them messages by entering their name in the 'block list' on the personal message control panel.

Clarity: The layout of the home board is appealing, and the use of colour, line and space very professional in appearance. The discussion boards, however, contain much white space and require extensive scrolling.

Common Technical Framework: *Invision Power Board* requires PHP 4.3+ and either MySQL 3.23 or higher (4.0 + recommended), MSSQL, or *Oracle 9i* for database storage. The product is scalable and offers a wide range of applications and site integration. *IPS* offers a variety of software components for addition to the product. These include *Invision Gallery*, *Invision Blogs*, and *Invision Chat*.

Notable Features:

- Independent forum skins
- Detailed admin and moderator logs
- Detailed registration, topic, post and PM statistics
- Integrated language editor
- Integrated skin editor and CSS editor
- Allows for the formation of a portal
- Board traffic statistics (Note: the *WowBB* comparison chart incorrectly states *Invision Power Board* does not contain this feature).

Overall comments

Invision Power Board is marketed as an effortless, intuitive, and scalable bulletin board system. The product website states that it allows its clients to effortlessly build, manage, and promote an online community. “Advanced yet intuitive features, like multi-moderation, allow you to focus on developing your community, rather than wrestling with complex settings.” Immediately under this sales pitch, the site contains a link to the *Invision Power Board* User’s Guide, available for purchase at \$24.99 US. Ironically, this begs the question, “Why is a user guide necessary for an effortless and intuitive bulletin board system; and should the client have to pay extra for a guide that makes a purchased product functional?” Once the trial version of the software was downloaded, it quickly became evident why a client might feel motivated to pay more for the User’s Guide; for the product is saturated with features and options, and the administrator’s control panel is worse still. While some users may appreciate the flexibility offered by these multiple features and options, previous reports in this series (see reports [#8](#) and [#43](#)) have demonstrated that the majority does not.

3. *vBulletin*

vBulletin is described on the product website as a forums package and a ‘community solution’ for medium to large websites. It is a product of *Jelsoft Enterprises* based in the UK. It should be noted that the *WowBB* comparison table that initiated this review referred to the features of *vBulletin* v 3.0. The recent release of *vBulletin* 3.5 was evaluated, based on a review of information provided on the product website and online manual, the installation of the administrator’s demonstration software, and a guest login on a website that uses *vBulletin* as its communication platform (www.sportbikers.net).

Cost: see comparison table (see Appendix I).

Complexity: The online user manual is extensive: 26 sections and six appendices with a total of 535 pages/ entries. Maneuvering the board is complex and definitely cannot be described as intuitive. For example, the admin demo requires two sets of username/ passwords for access, and was available to the evaluation team for only 24 hours, at which point a new one had to be established or a request for an extension made.

Control: Controls are available at administrator, moderator, and user levels.

Clarity: *vBulletin* uses a minimum of colour and other design features, and the presentation is linear.

Common Technical Framework: As with the other two programs tested, *vBulletin* can be run on any machine that supports PHP and MySQL. It is scalable, and its database server and webserver can reside on separate machines. Compatible operating systems include *Solaris*, *Linux*, *BSD*, *Windows*, and *Mac*. The product supports BB Code and HTML in posts.

Notable Features: Features offered are extensive, and the number of ‘features’ noted under 21 headings totals 100! The following are the features worth noting:

- Printer friendly versions on ‘threads’
- Multiple public and private calendars

- Import facility – imports posts and members from other bulletin board systems
- Editable FAQ for boards.

Overall comments

vBulletin 3.5 is a feature-packed text-conferencing/ bulletin board, comparable in price to *Invision Power Board 2.0*. The extensive list of features does not translate into expanded functionality, however. In fact, the size limit of 19.5 kb for attachments and a 15-choice ‘user reputation ranking’ system are distracting. It would appear that the market to which *vBulletin* appeals is that of the technically expert and feature-needy customer.

Conclusions

Beginning as a simple comparison, this review became a full-scale evaluation of three conferencing systems. At one point in the review, the analysis became a contest between “features versus functionality.” In its eagerness to prove that they had more features than the competitors, the *WowBB* vendor presented a biased and inaccurate comparison table, which made an unfair comparison with an outdated version of *vBulletin* board, and incorrectly stated that board traffic statistics were unavailable on the *Invision Power Board*.

In conclusion, the reviewers offer the following commentary on the basic differences between the programs. The majority of features are common to all three systems, with varying degrees of control, automation, and customisation being the key differentiators. Since each offers an extensive list of ‘must have’ features, a potential buyer needs to conduct a time-consuming review of each product in order to make an informed selection. Unless specific features are critical, the ‘look and feel’ of the program, price, and ease with which answers to key questions can be found will likely be determining factors in a decision to purchase.

The next report in the series examines the features of high-cost audio/ videoconferencing packages

N.B. Owing to the speed with which Web addresses become outdated, online references are not cited in this report. They are available, together with updates to the current report, at the Athabasca University software evaluation site: <http://cde.athabascau.ca/softeval/>. Italicized product names in this report can be assumed to be registered industrial or trademarks.

JPB. Series Editor, Technical Notes

APPENDIX I

Comparison of the three products

Criteria	WowBB 1.65	Invision Powerboard 2.0	vBulletin 3.5
PRICING (in \$ USD)			
Lease	\$49/year	\$69.95/year	\$85/year
Buy	\$89	\$185	\$160
Upgrades	Free for 1 year only, major upgrades discounted after year/1	Included	Included with lease price. Free for 1 year with purchase, then 30./year
Web hosting	Starting at \$7.95 with purchase, or \$10.95/mo. with one year lease	Available: from \$10/mo. to \$75/mo. depending on the package purchased	Not offered
Support: online	Included	Included	Included
Support: telephone		Free for 1 year only	1 mo. \$60; 6 mos. \$180; 12 mo. \$300; Toll-free in US only
Other	90-day money back guarantee	Free installation by technicians	Moderate discounts for bulk purchase; Installation \$135/license Brand-free option \$120/license
COMMON KEY* FEATURE S/FUNCTIONALITY LIST			
<p>Polls Private Messaging Customisable templates Emoticons/Smilies Differentiated User Groups E-mail notification</p> <p>Attachments Event Calendar IP & email banning Multiple languages Multiple Moderators Full text searching</p> <p>Avatars Paid Subscriptions Bad word filter Search capability Board Traffic Statistics</p> <p>* features listed on websites vary from 40 to 100 separate items, not always reflecting separate and distinguishing functionalities</p>			
Auto install and upgrade	Yes	No	No
WYSIWYG editor	Yes, shows as you type	No	Yes
Integrated spell checker	Yes	No	No
Avatars	Yes	Yes	Yes
Board traffic stats	Yes	Yes	Yes
Read forums via email	Yes	No	No
Time-zone & daylight saving setting	Auto detection	Yes	Yes
Read forms via email	Yes	No	No
Users selectable by location	Yes, US only	No	No
Custom user profile fields	Coming soon	Yes	Yes
User reputation/rating	Yes, complex calculation termed 'mana'	No	Yes, 15 level rating
User manual	Online	\$24.99 user manual	Online, very large, 535 pages
Support	Private support forums & email	Support forums & e-mail	Support forums & e-mail
COPPA Compliant	Not indicated	Yes	Yes
Trial/demo	1 month	5 days	24 hour
Telephone Queries	No	Yes, sales & technical	Sales queries only

November – 2005

Technical Evaluation Report

52. Audio/ Videoconferencing Packages: High cost

Sonia Murillo, Mary Rizzuto and Urel Sawyers
Masters of Distance Education Programme
Athabasca University – Canada's Open University

Abstract

This report compares two integrated course delivery packages: *Centra 6* and *WebEx*. Both applications feature asynchronous and synchronous audio communications for online education and training. They are relatively costly products, and provide useful comparisons with the two less expensive products to be evaluated in the following report #53. The criteria used in the current evaluation include capacity, interactivity features, integration with learning management systems, technical specifications, and cost. The report ends with a short analysis of the currently emerging audio-conferencing software, *Google Talk*.

Product Trials

1. Centra 6

Centra 6 is an online platform for knowledge sharing and content management. The product embraces two earlier versions, previously rated in this series (*CentraOne* and *CentraNow*). It offers conference calls over a network using voice-over-Internet-protocol (VoIP) technology, and provides interactive tools to keep participants involved during distance learning sessions.

Capacity: Three types of *Centra* events are offered, differing in audience size and the event's purpose. 'Conferences' are large events involving minimal interactivity (e.g., organisation-wide annual meetings), for which the vendor recommends a maximum of 1000 concurrent participants. 'Symposia' are mid-sized events with higher levels of interactivity (e.g., learning events), with a recommended maximum of 500 concurrent participants. 'eMeetings' are online meeting spaces for small groups of up to 25 participants. The maximum concurrent user recommendation relates to the server resources required to maintain high levels of interactivity.

Interactivity Features: *Centra* presentations are created using *PowerPoint*, and can be supplemented by other text and graphics (.txt, .htm, .html, .gif, .jpg, .jpeg), *Flash*, *Shockwave*, and audio/ video (.avi, .au, .mov, .mpg, .mp2, .ra, .rm, .wav, .wmv, and .asx). During synchronous events, the session leader(s) use interactive tools such as the Whiteboard, Web Safari (co-browsing with session participants), and AppShare (for sharing with participants applications that reside on the leader's computer). The leader can create breakout rooms in which participants form smaller subgroups for discussions and group work. The leader can make changes to the session's agenda, and can enable/disable tools as needed, during the event.

The interface is user-friendly and the features intuitive (see Figure 1). Participants enter the event via unique IDs and passwords, and can download and view content before the session. Text-chat tools are available for public use (to all participants and the leaders) and private use (to the leader only). The participants and leader(s) interact during the event using text-chat and/ or microphone headsets. They can use interactive icons (Yes/ No Polling, Raised Hand, Laughter, and Applause), and see who is speaking via a highlighted microphone next to the person's name. Each event can be recorded for future viewing on demand. Participants can maneuver through recorded material though cannot complete embedded tests or polls. Survey results and administrative details are recorded in the *Centra 6* database for each event, and can be used to generate reports.

Figure 1. The *Centra 6* participant interface

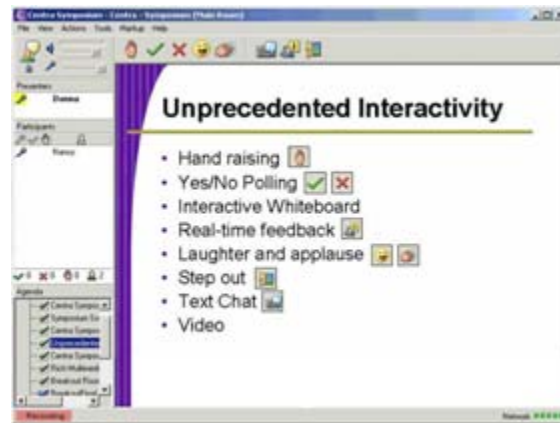

Learning Management Features: *Centra 6* contains a basic learning/ content management (LCM) tool. These features are expected to expand in Summer 2006, following the acquisition of *Centra Software* by *Saba Software*. New versions of *Saba* and *Centra* will be released containing integrated LMS/ LCMS and online delivery solutions. In its present form, *Centra* also integrates with other leading LMS products.

Technical Specifications: *Centra 6* operates on all current Windows platforms, permitting applications sharing by the leader and participants. The minimum requirements for the *Centra* client include:

- Windows 98, 2000 (SP1), or XP
- Internet Explorer 5.x, 6.x; Netscape 4.5x, 4.7x
- CPU: P350 MHz
- Memory: 128 MB
- Disk: 40 MB free space
- Network: 28.8 kbps
- Monitor: 16 bit colour

Centra 6 can run on the Macintosh OS, but the vendor cautions that slower speeds are experienced. The product is not configured to run on *Linux*.

Cost: The product can be hosted by the vendor and licensed individually, or, as in the current evaluation, hosted on the client's secure server. Pricing models are based on client specifications and volume discounts. Hosted on an institution's site, the cost is approximately \$200 per seat, with an additional annual maintenance fee of 18% of the original cost. When it purchased *Centra*

6 in 2003, the institution that collaborated in this study received large volume discounts and agreed to be a beta test client for *Centra 7*. This arrangement cost \$135,000 for 1000 concurrent users, including 24/ 7 telephone support by the vendor, and free training for internal staff. Additional costs were associated with integrating the platform into existing technical architecture.

2. *WebEx* (v 7.0.10)

This similar product is a Web-based real-time communication and collaboration tool, fully hosted by the vendor. Though primarily designed for business users, it also contains features useful in online education.

Capacity/ Cost: The product claims to be capable of hosting an “unlimited” number of participants, but with a cost restriction. The subscription fee is \$75 per named host per month. A named host is any individual allowed to schedule and host meetings. The package has a minimum of five named hosts. Each host can hold an unlimited number of meetings, one at a time, each with a maximum of 15 participants. A more expensive pay-per-use rate is available at \$0.33 US per user/ minute. On this basis, a 100-person meeting lasting an hour would cost \$2,000. An additional charge of \$0.20 per user/ minute is made for an ‘integrated teleconference,’ which participants join by calling a toll-free number, or by callback at their own number.

Interactivity Features: *WebEx* supports voice-over-Internet protocol (VoIP) a wide range of media types, a whiteboard, polling, and the opportunity to make notes during meetings. The interface is easy to use. The opening screen clearly shows the participants’ identities, and provides one-click functions for accessing synchronous text-chat, audio/ videoconferencing, and documents from the hard drive or from a connected storage drive. Access to a *WebEx* session is gained when the host schedules a meeting and sends the participants an invitation via email, telephone, or messaging applications. One of *WebEx*’s major features is its ability to share the host’s desktop, multiple documents, streaming media, and other applications, in order to demonstrate software or to edit files during a meeting. Participants can view the shared application, including cursor movements, without running the application that the host is sharing with them. Annotation tools enable the participants to use a pointer, type text, draw lines, construct shapes, designate colours, and erase. Presenters can synchronise all participants, allowing everyone to view the same display at the same magnification as the presenter’s display. When communicating, the host controls who speaks, and can pass the microphone to a participant. A participant who wishes to contribute can click the Raised Hand button. Figure 2 shows a screen capture of a *WebEx* meeting with browser sharing.

Figure 2. A *WebEx* meeting with browser sharing



Learning Management Features: *WebEx* was not designed specifically for educational purposes, and is limited in its learning management capabilities. Its ability to share webpages could be used with an LMS tool. For example, a teacher could allow participants to experience audio and video effects on a webpage by using Web content sharing to open that page on their computers. The product also has the ability to record and play back sessions on demand.

Technical Specifications: The *WebEx Meeting Manager* requires participants to have the following minimum computer specifications. For *Windows* 95, 98, NT, 2000 and XP: an *Intel Pentium* processor with 166 MHz and 32 MB RAM. This should be JavaScript and cookies-enabled, with a 56K + internet connection. For *Mac* users: *Power PC Macintosh G3*, 64 MB RAM, Virtual Memory on, JavaScript and cookies-enabled. The latest *Internet Explorer* or *Netscape* browsers are recommended, and there are no known issues with *Solaris* or *Linux*.

3. Google Talk

In view of the current interest being shown in the new *Google Talk* application, we have added a preliminary examination of it to this report. This is an instant messenger package integrating PC-to-PC calls, text-based chat and email. At present, this beta product does not appear to be ready for reliable usage, and we experienced obstacles gaining access to it. In order to use it, a 'gmail' account (*Google* mail) must be created. However, 'gmail' accounts are available only to users with a United States cell phone number. Having learned that the product has been reliably used by a colleague in Sri Lanka, we attempted to create an account with Canadian and Latin American cell phone numbers, though neither were accepted. Ultimately, we used a US colleague's number to gain access. *Google Talk* provides excellent audio quality and synchronicity, but the interface contains minimal user tools and is not user-friendly. During our test of the beta version, it was not possible to share files or to create a conference area, and adding a contact was only possible if the individual had a 'gmail' account. Given the rapid expansion of other *Google* products, however (e.g., *Google Earth* and *Picasa*), it is assumed that *Google Talk* will soon become a powerful online audio-conferencing option.

Conclusions

Centra 6 and *WebEx* both provide intuitive, user-friendly interfaces, and the rich multimedia interactivity required for effective collaborative distance education and communication. They have excellent collaborative features such as application-sharing, Web-sharing, and whiteboard, and *Centra* provides breakout rooms for small collaborative group activities. Its ability to interface with a variety of common learning management systems makes it appealing for distance educators seeking a full-package solution, but its associated high costs are unlikely to make it popular in the educational market. *WebEx* does not integrate with other systems as it is not hosted by the customer. A centrally hosted *Centra 6* package involves a one-time payment of approximately \$200 per seat, plus an additional annual maintenance fee of 18% of the original cost. *WebEx* is more economical at \$75 per seat per month, with a minimum of five seats per package. Moreover, *WebEx* operates on *Windows*, *Linux*, *Solaris*, and *Macintosh* platforms, whereas *Centra 6* is mainly configured for *Windows* and experiences a dramatic speed reduction with *Macintosh*. *Centra 6* and *WebEx* are appropriate products for their markets, but their specific features and benefits in relation to integration with other systems, hosting and associated costs should be evaluated by customers in relation to their organisational needs.

It is also instructive to compare the features of these products with those of other audio-conferencing software provided at a fraction of the above costs (see next report).

The next report in the series examines the features of low-cost audio/ video-conferencing packages.

N.B. Owing to the speed with which Web addresses become outdated, online references are not cited in this report. They are available, together with updates to the current report, at the Athabasca University software evaluation site: <http://cde.athabascau.ca/softeval/>. Italicized product names in this report can be assumed to be registered industrial or trademarks.

JPB. Series Editor, Technical Notes



November – 2005

Technical Evaluation Report

53. Audio/ Videoconferencing Packages: Low cost

Remi Tremblay, Barb Fyvie and Brenda Koritko

Masters of Distance Education Programme

Athabasca University – Canada's Open University

Abstract

A comparison was conducted of *Voxwire MeetingRoom* and *iVocalize v4.1.0.3*, both Web-conferencing products using voice-over-Internet protocol (VoIP) to provide unlimited, inexpensive, international audio communication, and high-quality Web-conferencing fostering collaborative learning. The study used the evaluation criteria used in earlier reports, including common technical framework, clarity, control, complexity, and costs. Criteria sub-divisions applying to one or more of the products' synchronous and asynchronous components are included in a side-by-side product comparison table. It is concluded that these two highly competitive products provide a serious challenge to the markets of their highly priced rivals. The report also contains a brief summary of *GRCLive*, another promising conferencing software, which the evaluation team attempted to evaluate, though gave up owing to technical difficulties.

Introduction

Given the increasing maturity of VoIP technologies, the evaluation team decided to examine two products (*Voxwire* and *iVocalize*) both with solid VoIP Web-conferencing capability, and features usually associated with higher priced collaboration packages (e.g., report #52). The report expands upon an earlier evaluation of *iVocalize* in this series (report #31). As the online free trial version provided by *iVocalize* is limited to a two-person Web-conference, and product demonstrations for *Voxwire* are provided via scheduled demonstrations, the necessary arrangements for the evaluation were made with the product vendors.

Product Trials

1. Voxwire

The *Voxwire MeetingRoom* provides unlimited computer-to-computer Web-conferencing application with features for synchronous audio and text-chat, browser-sharing, and presentations posted on the Internet. The meeting room is controlled by single or multiple moderators, with presentation and participant management features that can be pre-configured in the Room Configuration Panel, or modified during a session via the Moderator Menu. Moderators are able to synchronise all participant Web-browsers, poll the participants, mute the voice, and text chat of any participant, terminate participants, and, if necessary, ban them from returning to the conference for a specified duration. Participant features include synchronous audio, text-chat,

browser sharing, active participant list, adjustable text and presentation areas, a favorites list, active URLs in text-chat, adjustable text size, font, and colour, and private conversations. Presentations must be uploaded to the Internet prior to being presented, as *Voxwire* does not currently have an integrated file upload feature. The combination of moderator and participant features is controlled in a simple and intuitive interface. *Voxwire MeetingRoom* has limited collaboration and recording features, and appears to be more appropriate for larger group presentations.

Currently, *Voxwire* has limited support for older PC's (e.g., Pentium III with Windows/98), or for Web-browsers other than *Internet Explorer 6*. *Macintosh*, *Unix*, and *Linux* operating systems are not currently supported. *Voxwire* is available primarily as a hosted service, though, as Appendix I shows, private hosting is available at a substantially higher cost that may be beyond the reach of many educational institutions.

2. *iVocalize*

Since the previous *iVocalize* evaluation in (report #31), a new version has been released (v4.1.0.3), containing some changes of note. The audio/ text-chat helpdesk service is no longer available, and only email support is now provided. *Mac* and *Linux* support has been added since the previous review. Regrettably, the software purchase plan has been withdrawn, and only rental options for rooms and servers are now available.

Participant user features still include synchronous audio and text-chat; time-stamp on text entries; private conversations; active participant list; website/ presentation navigation; adjustable text area; favourites list; and active URLs in text-chat. The shared whiteboard includes a useful *PowerPoint* converter that allows for the synchronous presentations of slides, which can be annotated, as well as a screen capture mechanism that allows participants to capture images of any document, screen, or image. The accessibility features detailed in the earlier report now include improvements to the recording features using *Java* technology. Participants have the option of creating recordings that can be played back at a later date in a *Java*-enabled browser that synchronises mp3 audio, text-chat and websites/ slides presented in the main room. The recording files (.html, .jar, .bin, .mp3) are saved to the users' PC. Applications-sharing and file-transfer features announced in the 2004 review are still not included. As with *Voxwire*, the *iVocalize* conference room is controlled by moderators using a simple and intuitive interface. Moderators can synchronise participant browser windows, mute participant audio and chat, and disconnect participants as required, but cannot ban a participant unless they have room administration privileges. Private chat, presentation recording, and individual participant Web-browsing can be enabled or disabled in the room configuration, and blanket levels of annotation capability can be assigned to the participants and individualized during the session by a moderator.

It is to be hoped that the changes observed since the earlier review do not indicate that the *iVocalize* product is in difficulty, as it is a valuable audio-conferencing option for educational users.

3. *GRCLive*

GRCLive is a collaboration and conferencing software produced by *Grassroots Communications*. Three levels of conferencing are offered: *GRC Lite*, *GRC Business Edition*, and *GRC Pro*. Common to all three products are secure document and application sharing, file storage and transfer, Web-browser sharing, text-chat, document printing, calendar, and scheduling. The

Business Edition adds audio and multipoint videoconferencing capabilities, session recording and playback, remote desktop, and instant messaging features. The top-tier *GRC Pro* contains all of these features, plus VoIP dialing and polling.

Pricing for *GRC Lite* begins at \$29.95 USD per month for five concurrent users, and increases incrementally to \$449.95 per month for 25 concurrent users using *GRC Pro*. At the time of writing, *GRC* and its parent company, *Newport*, offer limited technical support for this product, and the current evaluation was halted when technical problems were encountered, which could not be resolved. *GRCLive* has also developed a new product entitled *Conga*, whereby users can instantly share documents, use VoIP calling, participate in text/ audio/ videoconferences, and send instant messages through *Yahoo Messenger*, *AIM*, *MSN Messenger*, and *ICQ*. *Conga* is currently available in beta edition, though internal sources suggest that resources for its continued development, evaluation, and testing are also unlikely to be made available before early 2006.

Conclusions

Voxwire and *iVocalize* are both user-friendly, cost-effective options for online audioconferencing, briefings, and presentations to large audiences. The comparison of the two products indicates that *iVocalize*, in particular, provides impressive capabilities comparing well to the features usually associated with higher priced collaboration packages (see report #52). In addition, *iVocalize*'s minimum system requirements are considerably less than those required for *Voxwire* (see the comparison table provided at the end of this report in the Appendix). The *iVocalize* developers appear to have concentrated on adding collaborative tools such as a sharable whiteboard, and joint uploading/ annotation of presentations and images. Another valuable feature, not provided in *Voxwire*, is the ability for participants and moderators to record and playback sessions at a later date using Web and mp3 technologies. *Voxwire*'s strengths are in its marketing and customer service options, with better documentation, a comprehensive website, and the flexibility for clients to deploy the product from their own server. In addition, *Voxwire* has a polling feature.

Given the opportunity to use both products, the evaluators chose to use *iVocalize* to collaborate at a distance in creating this report. Its presentation and asynchronous features make it a superior tool for distance educators who require a collaborative learning environment using VoIP technology. Little advantage appears to be gained in the use of highly expensive conferencing products such as those examined in the previous report #52. *iVocalize* and *Voxwire* appear positioned to provide these higher priced software packages with a "run for their money." *GRCLive* is a promising product in this genre, though currently lacking in technical support.

N.B. Owing to the speed with which Web addresses become outdated, online references are not cited in this report. They are available, together with updates to the current report, at the Athabasca University software evaluation site: <http://cde.athabascau.ca/softeval/>. Italicized product names in this report can be assumed to be registered industrial or trademarks.

APPENDIX I: Comparison of the two main products

	<i>Voxwire Meeting Room</i>	<i>iVocalize v4.1.0.3</i>
COMMON TECHNICAL FRAME WORK		
Product launch	2003	2002; current version hosted by vendor only.
Purchase/rental options	Managed or Private Server. The managed server is recommended for groups of 1000+. (See Costs section for scalability details.)	Earlier versions were available as freeware or as one-time license purchases. Most recent version (v4.1.0.3) has 1000+ seats. (See Costs section for scalability details.)
Minimum System Requirements (user)	<p><i>Pentium IV</i> or compatible; 256 MB RAM; <i>Windows 2000</i>; <i>Internet Explorer 6</i>; 56K dial-up connection; hard Drive free space: 10 MB.</p> <p><i>Macintosh, Unix, and Linux</i> operating systems are not currently supported.</p>	<p>266 MHz <i>Pentium</i> computer; 64 MB RAM; <i>Windows 98 SE</i> ; <i>Internet Explorer 6</i>; 56K dial-up connection; <i>Java v1.3</i> to play recorded presentations</p> <p>System requirements for <i>Mac</i> and <i>Linux</i>, and lesser used browsers (<i>Netscape, Firefox, Mozilla, Safari</i>)</p>

	Vox wire MeetingRoom	iVocalize v4.1.0.3
FEATURES		
Whiteboard	None	Shared with synchronous and interactive annotation; not easily printable or saveable; icon for easy upload of <i>PowerPoint</i> and image files.
Presentations	<i>PowerPoint</i> presentations cannot be uploaded directly; prior uploading of individual slides enables viewing through co-browser technology; slides must be converted by user into .jpg or .gif formats, or using vendor's conversion service; presentations cannot be annotated.	Uploaded into whiteboard window; <i>PowerPoint</i> presentations can be uploaded directly; <i>PowerPoint</i> button on whiteboard toolbar; <i>PowerPoint 2000</i> format, without special effects (as with larger commercial conferencing packages); maximum file size: 3MB.
Chat	Participants and moderators can send group/ private text messages;	Participants and moderators can send group/ private text messages;
Recording	text color and font options. None	text color and font options. Moderator and participants can record presentation simultaneously; presentation saved as html, with option of viewing presentation, text chat, and slides with mp3 audio.
Keyboard shortcuts	Yes	Yes
Polling	Yes	No
Screen capture	No	Enables participants to share screen displays
COMPLEXITY		
Registration/Purchase	MasterCard/ Visa/ American Express credit card	MasterCard/ Visa/ American Express credit card; PayPal preferred.
Login	24/7 access to private conference room; individual user name and passwords accounts;	24/7 access to private conference room; individual user name and passwords accounts.
Customisation	guest links sent to participants, or option to place graphic button on website. Brandable interface; clear, logical configuration of window layout and colour scheme.	Brandable interface; multilingual; clear, logical configuration of window layout and colour scheme; customised login page and URL (youname.ivocalize.net).

	Vox wire MeetingRoom	iVocalize v4.1.0.3
CLARITY		
Audio	Clear	Clearer than <i>Voxwire</i>
Intuitivity	Easy to use;	Easy to use;
Technical support	chat, private chat, and audio all intuitive. FAQ; telephone support, pay-on-demand; troubleshooting guide; e-mail support; onscreen "bubble help".	chat, private chat, and audio all intuitive. FAQ; user's guide Room Control Panel (for room manager); e-mail support; rollovers on menus only; Help button in Help menu did not work team during this evaluation.
Accessibility	Options menu with limited accessibility sub-menu	Numerous items on Help menu
CONTROL		
Moderator controls	Room Configuration Panel specifies control features for participants in advance (no recording or annotation); multiple presentations by multiple moderators, but presentations must be uploaded to web site; "Follow me" control: moderator can sync web pages to ensure that all users see the same page. With multiple moderators, only one may activate the "Follow Me" mode; moderator can terminate a participant from a session or ban a participant from a room; moderator options include private text messaging, and sending a single web page to participants.	Room Manager specifies control features for participants in advance; multiple presentations by multiple moderators; moderator synchronisation helps differentiate control between moderators and their presentations; "Synchronized browsing": moderator can sync web pages to ensure that all users see the same page. With multiple moderators only one may activate the "Synchronized browsing" mode; moderator can only ban a participant through the Activity Section of room control; moderator options include private text messaging, and sending a single web page to participants.
Co-browsing	Controlled by moderator only; participants follow moderator's browser.	Between moderator and participants.
COSTS		
Set-up fee	One-time \$15 setup fee, plus room costs (below):	No

	Vox wire MeetingRoom	iVocalize v4.1.0.3
Usage costs	<p>Personal Meeting Room</p> <ul style="list-style-type: none"> 2 concurrent users - \$9.95/mo. 5 concurrent users - \$14.95/mo. <p>Group Meeting Room</p> <ul style="list-style-type: none"> 10 concurrent users - \$29.95/mo. 100 concurrent users - \$164.95/mo 1000 concurrent users - \$1,514.95/mo 1000+ available <p>Managed Server</p> <ul style="list-style-type: none"> Rent a server managed by Voxwire Setup - \$200, Monthly fee - \$200 <p>Private Server</p> <ul style="list-style-type: none"> Install Voxwire on your server Installation - \$2995 500 seats (min) - \$5 per seat/mo. 10,001 – 50,000 - \$2 per seat/mo. 	<p>Personal/Group Conference Room</p> <ul style="list-style-type: none"> Charged per user 3 concurrent users - \$15.00/mo. 5 concurrent users - \$20.00/mo. 10 concurrent users - \$40.00/mo. 20 concurrent users - \$70.00/mo. 30 concurrent users - \$100.00/mo. 50 concurrent users - \$150.00/mo. 100 concurrent users - \$300.00/mo 150+ available for quoted cost <p>Multiple Room Packages</p> <ul style="list-style-type: none"> Multiple independent rooms Flat rate per room, unlimited use <p>Virtual Server Packages</p> <ul style="list-style-type: none"> Rent server from iVocalize Ability to create own conference rooms Price dependent on number of concurrent users
Technical support	Telephone support, pay-on-demand: \$25/15 minutes	Very limited, no cost
Extras	Conversion of Power Point slides: \$49.95 for up to 10 slides, and \$5 per slide for additional slides	No extra costs

