

**Documents in Support of  
The Honourable Elmer MacKay's Testimony**

<b>Tab</b>	<b>Documents</b>
<b>1</b>	Minutes: Cabinet Committee on Priorities and Planning, dated February 11, 1986 <u>Document # AGC00460</u>
<b>2</b>	Thyssen/Bear Head Industries Proposals - Chronology and Current Status, undated (covers events from 1987 to 1991) <u>Document # AGC00422</u>
<b>2(a)</b>	Notes on a meeting held in the Office of the Minister responsible for ACOA on October 20, 1987 <u>Document # AGC00981</u>
<b>3</b>	Letter from Karlheinz Schreiber to Elmer MacKay, dated December 8, 1987 <u>3<sup>rd</sup> party document</u>
<b>4</b>	Summary of Record, Committee of Atlantic Ministers, dated June 14, 1988 <u>Document # AGC00401</u>
<b>5</b>	Aide-Memoire, dated September 19, 1988 <u>Document # AGC00014</u>
<b>6</b>	Understanding in Principle, dated September 27, 1988 <u>3<sup>rd</sup> party document</u>
<b>6(a)</b>	Memorandum from D. McPhail to Elmer MacKay, dated September 6, 1989 <u>Approved Cabinet Confidence document</u>
<b>7</b>	Memorandum from Peter Lesaux to Elmer MacKay, dated October 26, 1989 <u>Approved Cabinet Confidence document</u>
<b>8</b>	Letter from Elmer MacKay to Harvie Andre, dated October 31, 1989 <u>Approved Cabinet Confidence document</u>
<b>9</b>	Letter from Karlheinz Schreiber to Elmer MacKay, dated November 28, 1989 <u>3<sup>rd</sup> party document</u>
<b>10</b>	Letter from Karlheinz Schreiber to Elmer MacKay, dated November 29, 1989 <u>3<sup>rd</sup> party document</u>
<b>11</b>	Letter from Harvie Andre to Elmer MacKay, dated December 4, 1989 <u>Approved Cabinet Confidence document</u>
<b>12</b>	Memorandum from Peter Lesaux to Elmer MacKay, dated January 4, 1990 <u>Approved Cabinet Confidence document</u>
<b>13</b>	Note for Operations Committee, dated January 22, 1990 <u>Approved Cabinet Confidence document</u>
<b>14</b>	Memorandum from Ronald Bilodeau to Mr. Protti, dated January 24, 1990 <u>Approved Cabinet Confidence document</u>
<b>15</b>	Memorandum from Ronald Bilodeau to Mr. Tellier, dated January 25, 1990 <u>Approved Cabinet Confidence document</u>
<b>16</b>	Letter from Bill McKnight to Karlheinz Schreiber, dated January 25, 1990 <u>3<sup>rd</sup> party document</u>
<b>17</b>	Letter from Karlheinz Schreiber to Robert Fowler, copying Elmer MacKay,

	dated February 13, 1990 <u>Document # AGC00306</u>
18	Letter from Karlheinz Schreiber to Elmer MacKay, dated March 5, 1990 <u>3<sup>rd</sup> party document</u>
19	Letter from Karlheinz Schreiber to Elmer MacKay, dated March 13, 1990 <u>3<sup>rd</sup> party document</u>
20	Letter from Bill McKnight to Stanley Hartt, dated March 22, 1990 <u>Document # AGC00484 001</u>
21	Letter from Karlheinz Schreiber to Elmer MacKay, dated April 5, 1990 <u>Document # AGC00307</u>
22	Letter from Laurent Beaudoin to Brian Mulroney, dated May 11, 1990 <u>Document # AGC00022</u>
23	Letter from Karlheinz Schreiber to Paul Tellier, dated July 6, 1990 <u>3<sup>rd</sup> party document</u>
24	Letter from Karlheinz Schreiber to Robert Fowler Copying Elmer MacKay, dated July 6, 1990 <u>3<sup>rd</sup> party document</u>
24(a)	Memorandum from Paul Tellier to Brian Mulroney, dated July 12, 1990 <u>Document # AGC00855</u>
25	Letter from Paul Tellier to Karlheinz Schreiber, dated July 13, 1990 <u>3<sup>rd</sup> party document</u>
25(a)	Memorandum from Peter Lesaux to Elmer MacKay, dated August 23, 1990 <u>Waiting for the document to be released</u>
26	Letter from Karlheinz Schreiber to Brian Mulroney, dated August 27, 1990 <u>3<sup>rd</sup> party document</u>
27	Memorandum from R.N. Sturgeon, dated Oct. 90 <u>Document # AGC00023</u>
28	Letter from Elmer MacKay to Brian Mulroney, dated October 17, 1990 <u>3<sup>rd</sup> party document</u>
29	Note from R.D. Gillespie, dated November 30, 1990 <u>Document # AGC00111</u>
29(a)	Memorandum of Understanding, dated November 1990 <u>Document # AGC00406</u>
29(b)	Note by R.D. Gillespie, dated November 30, 1990 <u>Document #AGC00110</u>
30	Memorandum from Paul Tellier to Norman Spector, dated December 10, 1990 <u>Approved Cabinet Confidence document</u>
31	Memorandum from Peter Smith to Elmer MacKay, dated December 10, 1990 <u>Approved Cabinet Confidence document</u>
32	Memorandum from Frederick Gorbet to the Minister, dated December 10, 1990 <u>Approved Cabinet Confidence document</u>
33	Letter from Elmer MacKay to Brian Mulroney, dated December 11, 1990 <u>Approved Cabinet Confidence document</u>
34	Letter from Elmer MacKay to Norman Spector, dated December 19, 1990 <u>Approved Cabinet Confidence document</u>
35	Telcon with McDowell, dated January 9, 1991

	<u>Document # AGC00493</u>
<b>36</b>	Memorandum from Paul Tellier to Norman Spector, dated January 16, 1991 <u>Approved Cabinet Confidence document</u>
<b>36(a)</b>	Letter from Peter Smith to William Rowat, dated January 9, 1991 <u>Approved Cabinet Confidence document</u>
<b>37</b>	Letter from Gillespie to William Rowat, dated January 28, 1991 <u>Approved Cabinet Confidence document</u>
<b>38</b>	Memorandum of Understanding, dated April 9, 1991 <u>AGC document</u>
<b>39</b>	Letter from Karlheinz Schreiber to Brian Mulroney, dated April 19, 1991 <u>3<sup>rd</sup> party document</u>
<b>40</b>	Memorandum from Greg Alford to Jurgen Massmann and Karlheinz Schreiber, dated April 30, 1991 <u>3<sup>rd</sup> party document</u>
<b>41</b>	Email to R. Gilbert from ED Champagne, copying CA Kerr, BL Thomas, and Maj MK Brandon, dated June 18, 1991 <u>Document # AGC 00310</u>
<b>42</b>	Letter from Karlheinz Schreiber to Michael Wilson, dated August 21, 1991 <u>3<sup>rd</sup> party document</u>
<b>43</b>	Memorandum from Glen Shortliffe to Hugh Segal, dated September 17, 1992 <u>Approved Cabinet Confidence document</u>
<b>44</b>	Letter from Karlheinz Schreiber to Marcel Masse, copying Brian Mulroney and Elmer MacKay, dated May 13, 1992 <u>Document # AGC00030</u>
<b>45</b>	Selected agenda entries made by Karlheinz Schreiber (1993) <u>3<sup>rd</sup> party documents</u>
<b>46</b>	Letter from Karlheinz Schreiber to Brian Mulroney, dated March 16, 1993 <u>3<sup>rd</sup> party document</u>
<b>47</b>	Selected agenda entries made by Karlheinz Schreiber (1994) <u>3<sup>rd</sup> party documents</u>
<b>48</b>	Timeline:1999 – 5 <sup>th</sup> estate <u>Open source</u>
<b>49</b>	National Post: Mulroney asks Schreiber to clear the Airbus air (Philip Mathias), dated August 20, 1999 <u>Open source</u>
<b>50</b>	Statement made by Elmer MacKay, dated October 5, 1999 (removed) <u>Document # AGC00383</u>
<b>51</b>	Letter from Karlheinz Schreiber to Brian Mulroney, dated January 14, 2004 <u>3<sup>rd</sup> party document</u>
<b>52</b>	Email & Letter from Karlheinz Schreiber to Brian Mulroney, dated July 20, 2006 <u>3<sup>rd</sup> party document</u>
<b>53</b>	The Chronicle Herald Nova Scotia: MacKay: Just trying to help, dated December 5, 2007 <u>AGC document</u>
<b>54</b>	Letter from Karlheinz Schreiber to Brian Mulroney, dated January 29, 2007 <u>Document # AGC00253</u>

<b>55</b>	Letter from Elmer MacKay to Brian Mulroney, undated <u>3<sup>rd</sup> party document</u>
<b>56</b>	Letter from Elmer MacKay to Brian Mulroney, undated <u>Approved Cabinet Confidence document</u>







CANADA

1986

Serial # 10-86CMPP  
No de serie

This document consists of 16 pages  
Ce document comprend

This document is the Property of the Government of Canada. It is for Ministers' eyes only.

La présent document est la propriété du gouvernement du Canada et est réservé aux ministres.

The Cabinet Committee on Priorities and Planning

Le Comité du Cabinet chargé des Priorités et de la planification

Minutes

A meeting of the Cabinet Committee on Priorities and Planning was held in Room 323-S, House of Commons on Tuesday, February 11, 1986, at 9:30 a.m.

Procès-verbal

Une réunion du Comité du Cabinet chargé des Priorités et de la planification a eu lieu dans la pièce 323-S, Chambre des Communes, mardi le 11 février 1986, à 9 h 30.

MINISTRE DU CABINET

DOCUMENT DU CABINET DOCUMENT DU CABINET DOCUMENT

NOT TO BE PHOTOCOPIED OR REPRODUCED NÉ PAS PHOTOCOPIER OU REPRODUIRE

SECRET

Present

The Prime Minister  
(Mr. Mulroney)  
in the Chair,  
The Secretary of State  
for External Affairs  
(Mr. Clark),  
The Minister of  
Employment and  
Immigration  
(Miss MacDonald),  
The Deputy Prime Minister  
and Minister of National  
Defence  
(Mr. Nielson),  
The Minister of  
Transport  
(Mr. Mazankowski),  
The Minister of National  
Revenue  
(Mr. MacKay),  
The Minister of  
National Health and  
Welfare  
(Mr. Epp),  
The Minister of Regional  
Industrial Expansion  
(Mr. Stevens),  
The President of the  
Queen's Privy Council  
for Canada  
(Mr. Hnatyshyn),  
The President of the  
Treasury Board  
(Mr. de Cotret),  
The Minister of Finance  
(Mr. Wilson),  
The Minister of  
Consumer and Corporate  
Affairs  
(Mr. Côté),  
The Minister of  
Communications  
(Mr. Masse).

Also present

Mr. S. Hartt  
(Department of  
Finance)  
Mr. C. McMillan  
Mr. B. Roy  
Mr. G. Norguay  
(Prime Minister's  
Office)  
Mr. G. Veilleux  
(Federal-Provincial  
Relations Office)  
  
The Secretary to the  
Cabinet  
(Mr. P. Tellier)  
  
The Deputy Secretary  
to the Cabinet (Plans)  
(Mr. I.D. Clark)

Étaient présents

Le Premier ministre  
(M. Mulroney)  
Président,  
Le Secrétaire d'État aux  
Affaires extérieures  
(M. Clark),  
Le ministre de  
l'Emploi et de  
l'Immigration  
(Mlle MacDonald),  
Le Vice-premier ministre  
et ministre de la Défense  
nationale  
(M. Nielson),  
Le ministre des  
Transports  
(M. Mazankowski),  
Le ministre du Revenu  
national  
(M. MacKay),  
Le ministre de la Santé  
nationale et du Bien-être  
social  
(M. Epp),  
Le ministre de l'Expansion  
industrielle régionale  
(M. Stevens),  
Le président du Conseil  
privé de la Reine pour le  
Canada  
(M. Hnatyshyn),  
Le Président du Conseil  
du Trésor  
(M. de Cotret),  
Le ministre des Finances  
(M. Wilson),  
Le ministre de la  
Consommation et  
des Corporations  
(M. Côté),  
Le ministre des  
Communications  
(M. Masse).

Étaient aussi présents

M. S. Hartt  
(Ministère des Finances)  
  
M. C. McMillan  
M. B. Roy  
M. G. Norguay  
(Cabinet du premier  
ministre)  
M. G. Veilleux  
(Bureau des Relations  
fédérale-provinciales)  
  
Le secrétaire du Cabinet  
(M. P. Tellier)  
  
Le sous-secrétaire du  
Cabinet (Plans)  
(M. I.D. Clark)

Secretary

Mr. E. Blackburn  
(Privy Council  
Office)

Secrétaire

M. E. Blackburn  
(Bureau du Conseil  
privé)

Assistant Secretary

Mr. P. Thibault  
(Privy Council  
Office)

Secrétaire adjoint

M. P. Thibault  
(Bureau du Conseil  
privé)

Contents  
Objets

<u>Items</u> <u>Articles</u>	<u>Pages</u>
General Discussion: Japanese-Canadian Redress/Discussion d'ordre général: Réparations à l'égard des canadiens d'origine japonaise	4
General Discussion: Privy Council Appointment /Discussion d'ordre général: Nomination au Conseil privé	4
Thyssen AG: Investment in Nova Scotia/ Thyssen AG: Investissement de la Société en Nouvelle-Ecosse	5
House Business/Affaires de la Chambre	6
Program Review Task Force: Communications/ Groupe d'étude sur la Revue des programmes: Communications	7
"Equality for All" Report/Rapport "Égalité pour tous"	8
Atlantic Enterprise Program/Programme Entreprise Atlantique	9
Ratification of the Decisions of Cabinet Committees/Ratification des décisions des comités du Cabinet	12
Patent Rules Governing the Registration of Patent Agents/Règles sur les brevets régissant l'inscription des agents de brevet	12
Canada-Quebec Memorandum of Understanding on the Development of the French-Language Television System/Entente de concertation et d'harmonisation Canada-Québec sur le développement du système de la télévision francophone	13
Coordination of Communications/Coordination des communications	14
The Government's Response to the Eighth Report of the Standing Committee on Public Accounts (Respecting the Canadian International Development Agency)/Réponse du gouvernement au huitième rapport du Comité permanent des comptes publics (portant sur l'Agence canadienne de développement international)	15
Orders in Council/Décrets	15

SECRET



Thyssen AG:  
Investment in Nova Scotia

Thyssen AG: Investissement  
de la société en Nouvelle-Ecosse

The Committee had for consideration a memorandum on Thyssen AG - Investment in Nova Scotia submitted by the Minister of State for External Affairs (1-0043-86MC(01), MC(02)RP and MC(03), dated January 30, 1986.

The Secretary of State for External Affairs reported that the Cabinet Committee on Foreign and Defence Policy had not been able to reach a consensus on the Thyssen proposal to establish a plant in Cape Breton. He believed that the proposal should, however, be turned down on foreign policy, domestic and economic grounds.

In foreign policy terms, Thyssen was seeking approval to build and export tanks from Canada to the Middle East. Canada did not export arms to the region, and had traditionally followed a policy of balance. Arms exports to Algeria might eventually find their way into the hands of the Polisario. While there was not a state of war between Israel and her Arab neighbors, the longer term outlook was more difficult to predict. The Canadian Ambassador to Israel reported that the Thyssen proposal, if accepted, would elicit strong reaction by the Israeli government which would interpret it as a dramatic change in Canada's even-handed posture towards the Middle East. Finally, Thyssen was a German firm with a particular history which was prevented, by German law, from exporting weaponry to the Middle East. This raised the question of why Canada should be prepared to act as a surrogate.

Mr. Clark noted that a forceful negative reaction to a decision favoring Thyssen could be expected from certain domestic lobby groups. This would exacerbate tensions between various ethnic communities in Canada.

At the same time, the economics of the proposal were tenuous: there were no guarantees that Thyssen would be able to penetrate the U.S. defence market, and other potential markets in the Middle East were conjectural and dangerous. Once Thyssen was established in Canada, there could be pressures to further loosen export controls or to ensure that the Department of National Defence became a client, regardless of need. In conclusion, while it was important to promote regional development in Cape Breton, the Thyssen proposal was inappropriate and dangerous.

The Minister of Regional Industrial Expansion explained that Thyssen produced a wide range of products, both within and outside the Federal Republic of Germany. While the focus was on armoured vehicles, the Thyssen proposal afforded the opportunity to establish a major industrial complex in Cape Breton dealing *inter alia* with naval maintenance, machinery, material handling and airport engineering. Thyssen would employ 450 workers in the initial stages of

SECRET

CABINET DOCUMENT DU CABINET DOCUMENT DU CABINET DOCUMENT DU CABINET DOCUMENT DU CABINET DOCUMENT

DOCUMENT DU CABINET DOCUMENT DU CABINET DOCUMENT DU CABINET DOCUMENT DU CABINET

operation, and create 500 indirect jobs in Quebec and Ontario. The company was seeking only limited tax credits and infrastructure assistance. On export permits, Thyssen was not asking for ironclad preferential agreements but rather the application of conditions similar to those for General Motors (which was competing for defence contracts in Saudi Arabia). These should be reasonably non-restrictive. On balance, the Thyssen proposal offered the best prospects for Atlantic Canada and had the potential to become a second Michelin.

Mr. Stevens suggested that Israel's reaction would be tempered by the fact that other allies were active in the Middle East and that Israel itself was a major armaments exporter. If neutral countries, such as Sweden and Switzerland, could export military equipment, Canada should not be overly hesitant. Eventual pressures on National Defence to purchase from Thyssen should be considered in the light of regional benefits. At present, forty-eight percent of government procurement was centered on Ontario. The Thyssen proposal offered the opportunity to tackle regional disparities effectively.

In the ensuing discussion, the following points were made:

- (1) Ministers noted the need to proceed with prudence, given the serious international and domestic consequences that could arise as a result of any leaks.
- (2) Ministers felt that it was important to seek and to encourage viable projects for Cape Breton.

The Prime Minister noted that more information was required concerning the possibility of non-military production by Thyssen. The likely reaction of Israel to Canadian acceptance of the Thyssen proposal should also be analysed in greater detail. The Minister of Regional Industrial Expansion should contact Thyssen to determine whether the company would be prepared to vary its production line, rather than to concentrate solely on armoured vehicle production, and should report back to the Committee before a final decision was taken.

House Business  
(1-9062-86DI)

Affaires de la Chambre  
(1-9062-86DI)

The President of the Privy Council and Government House Leader noted that debate on the House reform package should conclude by February 12. The Registration of Lobbyists proposal would be introduced in committee shortly after a limited debate. Before the Budget was tabled at the end of the month, the

SECRET

following bills should have passed the final reading stage: the Employment and Equity Act, the Immigration Act, and the Excise Tax Act.

In the ensuing discussion, the following points were raised:

- (1) The Deputy Prime Minister noted that he would speak to regulatory reform on February 12 or 13, highlighting the responsibility of the President of the Privy Council for these issues and the creation of a distinct secretariat for regulatory affairs in the Privy Council Office.
- (2) Ministers recommended that the Prime Minister make a keynote statement in the debate on the broad issue of Parliamentary reform, given its historical significance and the role of the Prime Minister in this initiative.

The Prime Minister concluded the discussion by noting that he would make a statement in the House on Parliamentary reform in the afternoon of February 11.

Program Review Task Force:  
Communications  
 (9-9063-86DI)

Groupe d'étude sur la Revue  
des programmes: Communications  
 (9-9063-86DI)

The Deputy Prime Minister circulated a draft statement for comment and informed Ministers of a three phase communications plan to publicize the results of the program review initiative. The first stage, before the tabling of the Budget, would include announcements on regulatory reform, major surveys, and continued consultations with the provinces, all coordinated by the Cabinet Committee on Communications. The second stage would focus on the process of program review, including previously announced decisions, the budgetary impact of program review, and a commitment to the release of Task Force Study Team reports. These measures would be included in the Budget speech by the Minister of Finance. The third stage, post Budget, would involve briefings for Ministers and the caucus, as well as announcements of the date of release of the study team reports and of the creation of a special task force to examine the generic issues of program review. The twenty study team reports would likely be tabled in the week of March 10 and referred to the appropriate Standing Committees. Each report would contain a clear disclaimer noting that the analysis and recommendations of the mixed (public and private sector) study teams did not represent Government policy.

On the generic item, Mr. Nielsen confirmed that a special task force would examine the half-dozen

SECRET





Atlantic Enterprise Program  
(2-0042-86RD(02)(R))

Programme Entreprise Atlantique  
(2-0042-86RD(02)(R))

The Committee agreed that:

1. a new discretionary program of loan insurance and contributions towards interest costs (interest rate buy downs) for term loans of a minimum of \$250,000 for new capital investment be established within the Department of Regional Industrial Expansion, for the benefit of businesses in the Atlantic provinces and the Gaspé Region of Quebec;
2. a private sector advisory board, to be called the Atlantic Enterprise Board, which will play a key role in the delivery of the program, be established pursuant to section 7 of the Department of Regional Industrial Expansion Act;
3. the Atlantic Enterprise Board involve the Federal Business Development Bank to the extent feasible in implementing the Atlantic Enterprise Program;
4. regulations be put in place to allow the Minister of Regional Industrial Expansion to offer 85% insurance (up to 90% with direct ministerial approval and up to 95% with Minister of Finance concurrence) on losses on new term loans by approved lenders, as defined in Annex B to Cab. Dec. 2-0042-86MC(01), under vote 1(a) of the Department of Regional Industrial Expansion;
5. terms and conditions be established under vote 10 of the Department of Regional Industrial Expansion, to enable the Minister of Regional Industrial Expansion to provide contributions to buy down interest costs up to six percentage points, applicable to new term loans for new capital investment from approved lenders as defined in Annex B to Cab. Dec. 2-0042-86MC(01);
6. a reference be included in the Supplementary Estimates to resurrect vote L25 and expand it to give the Minister of Regional Industrial Expansion the authority to take stock options in connection with an insured loan, in addition to the authority to exercise such stock options;
7. the approved lenders pay an annual fee of 1% on outstanding loan balances to the Minister of Regional Industrial Expansion for payment to the Consolidated Revenue Fund;
8. sectors for which term loans and interest rate buy downs are available include elements of manufacturing, fabricating, processing, tourism, related service sectors and the primary sector, including agribusiness;
9. the details of sectors to be covered be defined in regulations and terms and conditions, after appropriate Ministerial and departmental consultations;

SECRET

C  
A  
B  
I  
N  
E  
T  
  
D  
O  
C  
U  
M  
E  
N  
T  
  
D  
O  
C  
U  
M  
E  
N  
T  
  
D  
O  
C  
U  
M  
E  
N  
T  
  
D  
O  
C  
U  
M  
E  
N  
T  
  
D  
O  
C  
U  
M  
E  
N  
T  
  
D  
O  
C  
U  
M  
E  
N  
TD  
O  
C  
U  
M  
E  
N  
T  
  
D  
O  
C  
U  
M  
E  
N  
T  
  
D  
O  
C  
U  
M  
E  
N  
T  
  
D  
O  
C  
U  
M  
E  
N  
T  
  
D  
O  
C  
U  
M  
E  
N  
T  
  
D  
O  
C  
U  
M  
E  
N  
T

10. loans for refinancing, for mergers, or for acquisitions not qualify for insurance or interest rate buy downs;
11. loans for working capital not generally be eligible for loan insurance or interest rate buy downs, but be considered by the Minister of Regional Industrial Expansion and the Minister of Finance in special circumstances, to be defined in the regulations;
12. federal, provincial, and municipal governments, Crown corporations, Crown agencies, and Crown companies, as well as their effectively controlled subsidiaries, not be eligible for assistance under the Atlantic Enterprise Program, or with the exception of the Federal Business Development Bank, be eligible as approved lenders;
13. the sunset date for applications received under the program be December 31, 1990;
14. the reference level of the Department of Regional Industrial Expansion be reduced by five percent per year of the amount of loan insurance issued for each of five fiscal years following such issuance; and
15. the Department of Regional Industrial Expansion fund the program from its existing reference levels and no additional financial resources be provided.

Le Comité convient:

1. que soit établi au sein du ministère de l'Expansion industrielle régionale un nouveau programme discrétionnaire d'assurance-prêts et de contributions visant à couvrir les frais d'intérêt (prise en charge d'une partie des frais d'intérêt) pour les prêts à terme d'au moins 250 000 \$ affectés à de nouveaux investissements qu'assument les entreprises de provinces de l'Atlantique et de la Gaspésie, au Québec;
2. que soit créé, en vertu de l'article 7 de la Loi sur le ministère de l'Expansion industrielle régionale, un organisme consultatif du secteur privé qui sera appelé Conseil de l'entreprise dans l'Atlantique et qui jouera un rôle de premier plan dans l'exécution du programme;
3. que le Conseil de l'entreprise dans l'Atlantique s'assure, dans la mesure où cela est faisable, la participation de la Banque fédérale de développement dans la mise en oeuvre du Programme Entreprise Atlantique;
4. que soit mis en oeuvre un règlement pour permettre au ministre de l'Expansion industrielle régionale d'offrir une assurance couvrant 85 p. 100 (pouvant aller jusqu'à 90 p. 100 avec l'approbation directe du ministre et jusqu'à 95 p. 100 avec l'accord du ministre des Finances) des pertes à l'égard de nouveaux prêts à terme consentis par des prêteurs désignés, tels que définis à l'annexe B du doc. du Cab. 2-0042-86MC(01), en vertu du crédit 1(a) du ministère de l'Expansion industrielle régionale;

5. que soient élaborées, en vertu du crédit 10 du ministère de l'Expansion industrielle régionale, des modalités permettant au ministre de l'Expansion industrielle régionale de fournir des contributions afin de prendre en charge jusqu'à six points de pourcentage du taux d'intérêt applicable aux nouveaux prêts à terme consentis par des prêteurs désignés, tels que définis à l'annexe B du doc. du Cab. 2-0042-S6MC(01), pour des nouveaux investissements;
6. que le crédit L25 soit réactivé dans le Budget des dépenses supplémentaires et que sa portée soit élargie pour autoriser le ministre de l'Expansion industrielle régionale à souscrire à des actions à l'égard d'un prêt assuré, en plus de l'autoriser à acheter ces actions;
7. que les prêteurs désignés versent au ministre de l'Expansion industrielle régionale des frais annuels correspondant à 1 p. 100 du solde des prêts en souffrance;
8. que seuls les secteurs de la fabrication, de la transformation, du tourisme, des services connexes et le secteur primaire, y compris le domaine agroalimentaire, soit admissibles à l'assurance et à la prise en charge d'une partie des frais d'intérêt pour les prêts à terme;
9. que des précisions sur les secteurs qui seront couverts soient formulées dans le Règlement et les modalités, après que des consultations aient eu lieu auprès des ministres et des ministères intéressés;
10. que les prêts effectués à des fins de refinancement, de fusion ou d'acquisition ne soient pas admissibles à l'assurance ni à la prise en charge d'une partie des frais d'intérêt;
11. que les prêts visant l'accroissement du fonds de roulement ne soient pas généralement admissibles à l'assurance ni à la prise en charge d'une partie des frais d'intérêt, mais que le ministre de l'Expansion industrielle régionale et le ministre des Finances les prennent en considération dans des circonstances particulières qui seront définies dans le Règlement;
12. que les gouvernements fédéral, provinciaux et municipaux, les sociétés, organismes et compagnies d'Etat, et les filiales dont ils ont le contrôle réel à l'exception de la Banque fédérale de développement, ne soient pas admissibles à l'aide accordée en vertu du Programme Entreprise Atlantique et ne puissent pas faire fonction de prêteurs désignés;
13. que la date limite de réception des demandes d'aide présentées en vertu du Programme soit fixée au 31 décembre 1990;
14. que le niveau de référence du ministère de l'Expansion industrielle régionale soit réduit chaque année de 5 p. 100 du montant de l'assurance-prêt émise, pour chacune des cinq années financières suivant l'octroi de l'assurance; et

SECRET

CABINET DOCUMENT DU CABINET DOCUMENT DU CABINET DOCUMENT DU CABINET DOCUMENT

DOCUMENT DU CABINET DOCUMENT DU CABINET DOCUMENT DU CABINET

- 15. que le ministère de l'Expansion industrielle régionale finance ce programme dans le cadre de son niveau de référence actuel et qu'aucune autre ressource financière supplémentaire ne soit consentie.

Ratification of the Decisions of Cabinet Committees

Ratification des décisions des Comités du Cabinet

The Cabinet Committee on Priorities and Planning ratified the Decision the Cabinet Committees as contained in the following Committee Reports:

Le Comité du Cabinet chargé des priorités et de la planification a ratifié les décisions des Comités du Cabinet telles qu'elles apparaissent dans les rapports suivants:

Patent Rules Governing the Registration of Patent Agents

Règles sur les brevets régissant l'inscription des agents de brevet

The Cabinet Committee on Economic and Regional Development at its meeting of February 4, 1986, had for consideration a Memorandum from the Minister of Consumer and Corporate Affairs (Cab. Doc. 6-0040-86MC(01), dated January 20, 1986) concerning the Government's response to the recommendation of the Third Report of the Standing Joint Committee on Regulations and other Statutory Instruments.

The Committee agreed that:

- 1. the provisions of the Register of Patent Agents Rules 1948, made pursuant to section 15(2) of the Patent Act be formally revoked, the present sections 152 to 158 of the Patent Rules made pursuant to section 12 of the Patent Act be revoked and re-enacted under the appropriate sections of the Patent Act.

Le Comité du Cabinet chargé du développement économique et régional a étudié, à sa réunion du 4 février 1986, un mémoire du ministre de la Consommation et des Corporations (doc. du Cab. 6-0040-86MC(01) du 20 janvier 1986) concernant la réponse du gouvernement à la recommandation du troisième rapport du Comité mixte permanent des règlements et autres textes réglementaires.

Le Comité convient :

1. que les dispositions des Règles de 1948 concernant le Registre des agents de brevet, établies aux termes du paragraphe 15(2) de la Loi sur les brevets, soient formellement révoquées, et que les articles 152 à 158 des Règles sur les brevets, actuellement en vigueur, établis aux termes de l'article 12 de la Loi sur les brevets soient révoqués et soient réadoptés en vertu des articles pertinents de la Loi sur les brevets.

Canada-Quebec Memorandum of Understanding on the Development of the French-Language Television SystemEntente de concertation et d'harmonisation Canada-Québec sur le développement du système de la télévision francophone

The Cabinet Committee on Economic and Regional Development at its meeting of February 4, 1986, had for consideration a Memorandum from the Minister of Communications (Cab. Doc. 4-0041-86MC(01), dated January 29, 1986) concerning the signing of a Memorandum of Understanding on the development of the French-Language television system.

The Committee agreed that:

1. the Minister of Communications be authorized to conclude a Memorandum of Understanding (MOU) on the development of the French-Language television system with the Government of Quebec; and
2. on the understanding that no additional financial commitment would be required, the \$200,000 funding required for the MOU for each of the four years from 1986/87 to 1989/90 be shared on a 50:50 basis with the Province of Quebec and be sourced from the Canada-Quebec Subsidiary Agreement for Communications Enterprises Development previously approved by Cabinet (Cab. Doc. 28-85RD).

Le Comité du Cabinet chargé du développement économique et régional a étudié, à sa réunion du 4 février 1986, un mémoire du ministre des Communications (doc. du Cab. 4-0041-86MC(01) du 29 janvier 1986) concernant la signature d'une entente de concertation et d'harmonisation sur le développement du système de la télévision francophone.

Le Comité convient :

1. que le ministre des Communications soit autorisé à conclure avec le gouvernement du Québec une entente de concertation et d'harmonisation sur le développement du système de la télévision francophone; et

SECRET

CABINET DOCUMENT DU CABINET DOCUMENT DU CABINET DOCUMENT DU CABINET DOCUMENT DU CABINET

DOCUMENT DU CABINET DOCUMENT DU CABINET DOCUMENT DU CABINET DOCUMENT DU CABINET

2. qu'étant entendu qu'aucun engagement financier supplémentaire ne sera requis, le financement de 200 000 \$ nécessaire aux fins de l'entente pour chacune des quatre années s'écoulant de 1986-1987 à 1989-1990 soit assumé à parts égales par le gouvernement du Québec et le gouvernement fédéral et provienne des fonds alloués à l'Entente auxiliaire Canada-Québec sur le développement des entreprises de communication qui a été approuvée par le Cabinet (doc. du Cab. 28-85RD).

Coordination of Communications  
(1-0047-86CR(01))(NSD)(E)

Coordination des communications  
(1-0047-86CR(01))(NSD)(F)

The Cabinet Committee on Economic and Regional Development, at its meeting of February 4, 1986, had for consideration a report from the President of the Treasury Board concerning the coordination of communications related to the Montreal region.

The Committee agreed that:

1. the Ministerial Committee on the Development of the Montreal Region be advised of all planned federal announcements affecting the Montreal region through the office of the Federal Economic Development Coordinator for the Quebec Region.

Le Comité du Cabinet chargé du développement économique et régional a étudié, à sa réunion du 4 février 1986, un rapport du président du Conseil du Trésor au sujet de la coordination des communications touchant la région de Montréal.

Le Comité convient:

1. que le Comité ministériel, sur le développement de la région de Montréal soit informé d'avance, par l'entremise du Coordinateur fédéral du développement économique pour la région du Québec, de toutes déclarations officielles du gouvernement du Canada touchant la région de Montréal.



The Government's Response to the Eighth Report of the  
Standing Committee on Public Accounts (Respecting the  
Canadian International Development Agency)

Réponse du gouvernement au huitième rapport  
du Comité permanent des comptes publics  
(portant sur l'Agence canadienne  
de développement international)

The Cabinet Committee on Foreign and Defence Policy at its meeting of Wednesday, February 5, 1986, had for consideration a Memorandum to Cabinet from the Minister of External Relations (Cab. Doc. 5-0045-86MC(01) of January 31, 1986) concerning a response to recommendations made by the Standing Committee on Public Accounts (Respecting CIDA).

The Committee agreed that:

1. Approval be given to the proposed response and that it be tabled in the House, with minor alterations in wording (as agreed to by Treasury Board and CIDA) designed to reflect the ongoing Treasury Board review process.

Le Comité du Cabinet chargé de la politique étrangère et de la défense a étudié, à sa réunion du 5 février 1986, un mémoire du ministre des Relations extérieures (doc. du Cab. 5-0045-86MC(01) du 31 janvier 1986) concernant la réponse du gouvernement aux recommandations formulées par le Comité permanent des comptes publics portant sur l'ACDI).

Le Comité convient:

1. que la réponse proposée soit approuvée et soit déposée à la Chambre des communes, avec des modifications mineures du libellé (que l'ACDI et le Conseil du Trésor ont acceptées pour tenir compte du processus d'examen permanent du Conseil du Trésor.

Orders in Council  
Décrets

Appointments:

1. Chairman of the Fisheries and Oceans Research Advisory Council  
- Mr. Gerald Neil Ewing  
(Order in Council P.C. 1986-591, dated March 10, 1986).



- 2. Member of the Fraser River Harbour Commission  
 - Mr. Lloyd Cornett  
 (Order in Council P.C. 1986-809, dated April 4, 1986).

The Deputy Secretary to the Cabinet  
 (Plans)  
 Mr. Ian Clark  
 Le sous-secrétaire du Cabinet  
 (Plans)

CABINET DOCUMENT

CABINET DOCUMENT



SECRET

THYSSEN/BEAR HEAD INDUSTRIES PROPOSALS

CHRONOLOGY AND CURRENT STATUS

CHRONOLOGY

- 1987-first half 1988 - Thyssen holds discussions with Government of N.S., secures commitments of support, incorporates Bear Head Industries (BHI), and opens discussions with Federal departments and Ministers;
- 27 Sep 88 - Understanding in Principle (UIP) signed between company and Ministers of ACOA, DND, ISTC;
- 1989-1990 - numerous initiatives by company to secure directed contract. Briefing notes, meetings, etc;
- Oct 90 - formal proposal by Thyssen to ACOA to provide 250 Fox vehicles for \$290M; original briefing material by DGSPDI successively updated by DDIR;
- 1 Nov 90 - MND, Minister Mackay, and senior officials meet with Mr. Spector to discuss proposal. Tasking to prepare detailed paper for PMO;
- 7 Dec 90 - DND input provided to Mr. Lesaux of ACOA;
- 8-10 Dec 90 - ACOA produces joint paper and passes to FCO/PMO;
- 11 Dec 90 - ACOA receives letter from Thyssen clarifying details of TH 495 offer;
- 12 Dec 90 - ACOA (Smith) letter to DND ADM(Mat) conveying minimum details of Thyssen letter (actual letter not provided to DND);
- 14 Dec 90 - DDIR re-write of DND analysis paper taking into account TH 495 offer, together with line by line proposed amendments to ACOA part of paper, and supplementals, speaking notes, crib notes (costing) etc for MND use at possible Ops Committee, passed to DGSPDI;
- 20 Dec 90 - letter from Premier of NS to Prime Minister speaking of Canada-NS Cooperation Agreement on Industrial Development Opportunities and specifically asking for PM support for Thyssen project. DGSPDI intervention with PPRO and PCO to ensure non-committal response;

SECRET

**SECRET**

- 9 Jan 91 - items from 14 Dec 90 bullet above (line by line amendments to ACOA paper and new DND analysis) passed by DGSPDI to PCO (Billings), thence to ACOA; not clear if briefing material sent to MND; ACOA calls DDIR to request diskettes ( provided by DDIR); ACOA produces new discussion paper and passes to PMO/PCO (copy provided to DDIR on 15 Jan only after verbally requested. DDIR passes copies to CLDO, PM MRCV. Copy enclosed);
- 9 Jan 91 - letter from Peter Smith to Bill Rowat (PCO) saying there was an inconsistency in DND analysis re TH 495;
- 17 Jan 91 - rebuttal letter to PCO, copy Peter Smith, to ADM(Mat) for approval and signature.

CURRENT STATUS

PCO (Billings and Gentles) best advice:

- 12 Dec 90 (approx) - discussion PM, Mackay (ACOA), Spector. PM expressed shock at cost of Thyssen proposal and asked Mackay to confirm numbers. Mackay accepted numbers were probably real. Spector advises Mackay not to push issue at present time. Mackay feels PMO has let him down i.e. purpose of 1 Nov meet was to force issue and this not done;
- no plans for matter to be discussed at Ops. Whether proposal dead, or to be handled outside of Ops not clear. She has asked the questions and may or may not get an answer. Only Spector knows;
- PM was to go to London in January and Mackay to FRG. Informal plan for PM to cross to FRG for possible meet with Thyssen. PM's trip cancelled.

CLDO (unconfirmed rumour)

- Gen Vance (ret'd) recommended to Thyssen that they back off, preserve remaining good will, and return to compete when time is right;
- PM has spoken by phone to Schreiber (Thyssen) within last 10 days.

**SECRET**



149

SECRET

Notes on a meeting held in the Office of the Minister responsible for ACOA on October 20, 1987 at 4 p.m.

Subject: Thyssen

Present: . Senator Lowell Murray  
. Honourable E. MacKay, Minister of National Revenue  
. Honourable F.D. Moores, Chairman of the Board, Government Consultants International  
. Paul Bernier, ACOA-Ottawa

Discussion: Mr. Moores provided background information on the current status of Thyssen's interest in establishing a military vehicle manufacturing facility in the Strait of Canso, Nova Scotia. In particular, he noted that:

- DND could develop specifications for its vehicle requirement within about a month if the time frame for production and funding were advanced; this was confirmed to him by General Vance;
- Thyssen's Board had approved the project;
- earlier discussions on a joint venture with General Motors had failed and were no longer being pursued; and
- discussions had been held recently with Bombarbier, Power Corporation and Lavalin.

He stated that there was apparent agreement to form a Thyssen-Lavalin joint venture in which Lavalin's equity position would be 25 percent. In addition, the joint venture would include the acquisition of the Hawker-Siddeley Trenton Works. The equity positions would be 75 percent Lavalin and 25 percent Thyssen. The understanding was that the two facilities created by the joint venture would be mutually exclusive.

Mr. Moores understood that Thyssen would have no difficulty in meeting DND's technical specifications, and would be able to offer an acceptable price to DND. However, he believed that DND objected to sole-sourcing. The addition of Trenton as an offset should minimize any difficulty with sole-sourcing, he suggested.

Senator Murray indicated that he had recently written to the Prime Minister to report on the Thyssen dossier and proposed to inform him of these most recent developments.

Mr. MacKay planned to raise the issue on 21 October with the Premier of Nova Scotia.

Paul Bernier  
October 22, 1987





## BEAR HEAD INDUSTRIES LIMITED

Suite 908, 350 Sparks Street  
Ottawa, Ont., Canada  
K1R 7S8

TELEPHONE (613) 563-3321

TELEFAX (613) 563-7648  
TELEX 053-3981 bhi ott

December 8, 1987.

Hon. Elmer MacKay, P.C., M.P.  
Minister of National Revenue  
Room 509  
Centre Block  
House of Commons  
Ottawa, Ontario  
K1A 0A6

Dear Mr. Minister:

I am writing to provide you with a short summary of the recent developments relating to our project at Bear Head, Cape Breton.

I have also written to Senator Lowell Murray, Lawrence O'Neil, M.P., and Robert Coates M.P. today to provide them with the same information.

Canadian Partner:

Lavalin Inc. has agreed to a joint cooperative agreement with Bear Head Industries to market Thyssen light armoured vehicles (LAVs) to Canada's DND. Both parties are actively exploring the opportunities for production cooperation at independently and/or jointly established facilities. (namely, at Bear Head and at the Trenton works).

Province of Nova Scotia:

Premier Buchanan and Minister Thornhill have committed, through the Nova Scotia Department of Development, an option for the land required for our plant. We will proceed with detailed discussions relating to the project as soon as a Federal commitment for vehicles is received.

U.S. Market Outlook for Thyssen:

The Thyssen Fuchs LAV was recently selected by the U.S. Army for a phase 1 order of 44 vehicles. The second phase of this order originally identified as 230 vehicles is now forecast at approximately 450 to 500 vehicles. As you are already aware, this is only a small part of \$200 billion U.S. Army program for armoured vehicles in the 1990s.





## BEAR HEAD INDUSTRIES LIMITED

### Project Status:

A North American expansion of Thyssen's industrial base is still focused on Cape Breton, Nova Scotia, as a preferred site, but to trigger such a large capital investment, we still need to receive a letter of intent from the Government of Canada that would commit a minimum of 250 vehicles from DND's required 1600 LAV requirement. This would naturally be subject to a vehicle being defined and designed cooperatively between Thyssen and DND to meet the operational requirements of DND from the entire range of Thyssen technology. I have prepared a draft of such a letter that would be sufficient to secure our project in Cape Breton starting immediately (attachment).

Please note that moving the LAV order forward to 1990 from the original DND procurement date of 1992 is no longer required by us. We would proceed immediately with construction of the plant and undertake to load the plant with civil work as well as some work from the U.S. LAV order until production for the Canadian order could commence.

This armoured vehicle production facility will be unique in Canada and provide a major addition to Canada's Defence Industrial Base, establishing a new capacity to produce DND requirements domestically. Not to be overlooked is the very high skilled labour content of these products which will be built in Nova Scotia but will impact on the entire country through sourcing of components and systems.

In addition to this initial military vehicle production, we plan to bring immediate diversification to the plant through civil manufacturing associated with existing North American Thyssen operations and North American joint ventures.

### Timing:

Having begun discussions with the Government of Canada in May of 1985, Thyssen cannot delay the decision of where to locate this North American manufacturing facility much longer. The increasingly encouraging market outlook in the U.S. helps to confirm the corporate decision to expand our North American operations by establishing this new facility, but understandably strengthens the case for locating in the U.S., and sites in that country are now being much more seriously considered. Time is of the essence.

If I can provide any further information on this subject, please do not hesitate to call me at 613-536-3321.

Sincerely,



Karlheinz Schreiber  
Chairman

Proposed draft Letter from Government of Canada to Bear Head  
Industries Ltd.

Based upon our policy of stimulating regional economic development through defence procurements and, conditional upon your establishment in Cape Breton of a suitable manufacturing facility, we commit to you an order for delivery in 1992 of the initial 250 light armoured vehicles of our 1,600 unit requirement, provided:

- a) in cooperation with DND you define and develop a vehicle from the entire range of Thyssen technology to meet DND operational requirements
- b) manufacturing of this vehicle will take place at your plant in Cape Breton, Nova Scotia
- c) you transfer the necessary technology to your facility in Cape Breton and share jobs with suitable Canadian manufacturing partners
- d) you meet our requirements in terms of quality, delivery and logistic support including personnel training
- e) you perform the aforesaid services/tasks at internationally acceptable prices





Atlantic Canada  
Opportunities Agency

Head Office  
P.O. Box 6051  
Moncton, N.B.  
Canada E1C 9J8

(506) 857-6523  
FAX: (506) 857-7403

Agence de promotion économique  
du Canada atlantique

Siège social  
B.P. 6051  
Moncton (N.-B.)  
Canada E1C 9J8

(506) 857-6523  
FAX: (506) 857-7403



SECRET

114

## SUMMARY RECORD

### COMMITTEE OF ATLANTIC MINISTERS

TUESDAY, JUNE 14, 1988

In attendance: Senator L. Murray (Chairperson)  
J.C. Crosbie  
S. McInnes  
E. MacKay  
G. Merrithew  
B. Valcourt  
D. Camp

Officials: D.S. McPhail  
N. Moyer

Minister Murray informed his colleagues that the Agency was making a further submission to the Treasury Board, requesting additional person-years. He noted officials had expected four times the workload, however, with the program expansion and improvements, the actual case load was ten times greater. A large percentage of ACOA resources, therefore, have been diverted to program delivery. Minister Murray expressed his concern that the advocacy and coordination roles would suffer as a consequence. Mr. McPhail remarked the submission was a modest increase given the volume of applications the Agency was dealing with. He added resources had been borrowed from other functional areas in the Agency to beef up the program side.

Mr. Merrithew remarked that only 1300 person-years was available for allocation in 1988-89, against a demand of 5000. Demands were coming from the free trade and tax reform initiatives, as well as many others. Mr. McPhail stated his Department was carrying on more programs than its predecessor, DRIE, in addition to its new initiatives. He further noted the Agency was operating with fewer people than DRIE, productivity was four times greater, and people were badly overworked. Minister Murray noted the Agency would not be able to meet its projected 30 day turn around under these conditions. Minister Murray asked that an Agency official get in touch with Ministers Merrithew and McInnes before the submission went forward to Treasury Board, to supply them with all the arguments possible. In addition, Mr. McPhail agreed to meet with Mr. Veilleux to discuss the matter further.

.../2

Canada

3451 0000122

3451 0000122



Faint, illegible text in the lower-left quadrant of the page.

Faint, illegible text in the lower-right quadrant of the page.

Faint, illegible text located near the bottom center of the page.

With respect to the Chair for Regional Development at the Université de Moncton, Minister Murray stated it would keep the profile of regional development high. He added that the universities had an integral role to play, and stressed the importance of encouraging a culture of entrepreneurship. Minister Valcourt would be making the announcement on behalf of Minister Murray.

Mr. McPhail informed that he had asked Thyssen officials to submit a business plan before the Chancellor's visit. In the plan, he wanted the company to confirm its intentions to move away from a firm commitment for light armoured vehicles, and instead, move towards more traditional regional development assistance and grants for their heavy industry facility. Mr. McPhail stated Thyssen had now backed away from the issue, because their associates in Ottawa had heard about a draft Memorandum to Cabinet from DND, allocating certain procurement to the West.

Mr. Mackay noted the possibility that sooner or later, their proposal could be overtaken by events. He stressed that Thyssen was prepared to put a major industrial presence in the region. Mr. McPhail stated that he did not see any alternative to this course of action. Minister Murray requested a note on this issue be written for the attention of the Prime Minister.

Concerning the Halifax Metro Agreement, Minister Murray explained that federal funds would be directed to particular parts of the agreement. He also noted the polluter pay principle. Minister Valcourt raised his concern about distancing from the perception that ACOA's funds were being used for infrastructure. Minister Murray agreed Mr. McInnes' announcement would have to be refined to address this concern.

With respect to the next round of ERDA meetings with his provincial colleagues, Minister Murray stated he had met with Premier McKenna and would be meeting with Premier Ghiz this week, and was arranging meetings with Premiers Peckford and Buchanan.

Ministers agreed it was necessary to have a list of management principles for the ERDA process for federal line departments, as well as a letter to line departments concerning further negotiations.

Meeting adjourned at 9:05 a.m.

Dale  
27.06.88

~~2451 0000123~~

2451 0000123







27  
37

Exempt - Cabinet

SECRET

Aide Mémoire

Aide Mémoire

A PROPOSAL BY BEAR HEAD  
INDUSTRIES TO ESTABLISH  
A HEAVY MANUFACTURING  
FACILITY IN CAPE  
BRETON

PROPOSITION DE LA BEAR  
HEAD INDUSTRIES POUR LA  
FABRICATION DE PRODUITS  
DE L'INDUSTRIE LOURDE.  
AU CAP-BRETON

September 19, 1988

le 19 septembre 1988

28  
38

AIDE MEMOIRE

**PURPOSE:** To develop an appropriate response by the Government of Canada to the proposal by Bear Head Industries Limited, (a subsidiary of Thyssen) to establish a heavy-industry manufacturing facility in Cape Breton, which would support the region's economic development.

**PROPOSAL:** Thyssen Industries AG, based in the Federal Republic of Germany, is one of the world's largest industrial manufacturing companies with annual sales exceeding \$30 billion, and 130,000 employees world wide. Of Thyssen's annual sales, less than 5% are in the defence sector.

In Canada, Thyssen's holdings include:

- Budd Canada Inc., Kitchener (automobile parts);
- Northern Elevator Holdings Ltd., Toronto (elevators);
- Greening Donald Co. Ltd., Hamilton (metal fabrication);
- Thyssen Marathon Canada Ltd., Mississauga (steel importers); and
- Thyssen Canada Ltd., Rexdale (steel importers).

In all, Thyssen employs some 3,000 Canadians.

Ba

In the U.S., the company has recently reached an agreement with General Dynamics concerning technology sharing for the production of light armoured vehicles for the U.S. military, further increasing Thyssen's existing North American commitment.

In 1985, the then DRIE Minister during a visit to Germany, requested that Thyssen submit a proposal to establish a manufacturing facility in Cape Breton. In March 1988, Thyssen submitted a revised proposal to the Government, through ACOA, to establish an \$85 million heavy-industry manufacturing facility at Bear Head, Cape Breton.

206

The initial capital cost of the facility would be \$58 million, assisted by the federal (and possibly the provincial) government in accordance with existing programs and guidelines. A further \$27 million for common-user infrastructure would be provided by the federal and the provincial governments. Thyssen would work closely in its production and subcontracting requirements with Lavalin (through the Trenton Works facility), possibly Sysco (to source its steel requirements), and Krauss Maffei, if the latter is successful in supplying DND with main battle tanks. Formal undertakings in support of these work-sharing arrangements are in place.

Thyssen proposes to establish the Bear Head facility in two phases:

- Phase I, the production of military vehicles for the North American defence market; and
- Phase II, diversification, within twelve months, into civilian production.

29  
31

SECRET

The exact product mix, and markets, associated with Phase II are currently being discussed with Thyssen, and the company is preparing a formal business plan for Phase II. Thyssen has consistently maintained that Phase I is a necessary launching pad for ultimate diversification into civilian production, and the company is willing to commit to repay portions of government funds received under Phase I, should Phase II not proceed.

**THE UNDERSTANDING IN PRINCIPLE:** The attached Understanding in Principle is not a formal Memorandum of Understanding (MOU), but instead, has been prepared to set out the nature of discussions to date. This document is required to initiate a decision from Thyssen's Board of Directors to proceed in Cape Breton. To this end, it is desirable that this document be signed by the ACOA Minister, the DRIE Minister, and the DND Minister.

While the Understanding in Principle formally binds neither the Government nor Thyssen in a manner which the other side would wish, the company is cited to be considered for participation in the light armoured vehicle project (part of the Government's projected modernization of the Canadian Forces, envisaged by DND to proceed in the early-to-mid 1990s), provided the company meets the Government's technical, operational and industrial/regional benefits requirements.

Since the Prime Minister's direction to Senator Murray in June 1987, to evaluate and report back on the Thyssen proposal, senior ACOA officials, in consultation with officials of DRIE, DND, and on occasion, PCO, Finance, Justice, and External Affairs, have met with Thyssen at length and developed further the company's heavy-industry proposal. Although Thyssen had originally sought a directed contract from the Government to provide DND with 250 LAVs in the early 1990s, the company has softened considerably its position, and is now willing to proceed with the heavy-industry facility on the basis of established government regional and industrial development assistance, and on the understanding that it will be considered for participation in the LAV program.

scnb

From the Government's perspective, the heavy-industry proposal for Cape Breton offers very considerable benefits, including technology transfer, to a particularly underdeveloped region of Canada. The Cape Breton plant would also pursue shared production and sourcing arrangements with Lavalin (at Trenton), and is ideally positioned to supply heavy-industry requirements of Hibernia.

At this point, Thyssen will commit to establishing a facility which would employ a minimum of 400 people. Employment is expected to grow considerably when diversification occurs.

**STATUS:** In order to report to the Prime Minister on the Thyssen proposal, the Prime Minister's Office and Senator Murray asked ACOA officials to take discussions

450  
48

with Thyssen to the point where the minimum undertakings required from the Government of Canada to allow the project to proceed, would be determined.

On September 12, Senator Murray met with Mr. de Cotret to discuss the Thyssen proposal. Mr. de Cotret agreed to sign the Understanding in Principle, in recognition that to proceed, the Bear Head proposal required the document as an interim step, prior to the development of a formal business plan.

Mr. de Cotret observed to Senator Murray that DRIE had some 800 projects seeking applications for financial assistance for which no DRIE funding was available. In this context, Mr. de Cotret stressed that the Government would have to develop a source of funds for projects valued in excess of \$20 million, and that, in the case of Thyssen, funds would have to be earmarked prior to Thyssen's submission of a business plan, and application for funding.

On September 14, Mr. Derek Burney chaired a meeting attended by Senator Murray and Mr. Beatty. Mr. Beatty agreed to sign the Understanding in Principle subject to further Ministerial discussion, as required, providing that:

- (1) the company be informed clearly that in signing the UIP, the Minister of National Defence was not binding the Government to proceed with the LAV project;
- (2) a letter be sent from the DND Minister to the ACCA Minister noting that in signing the Understanding in Principle, the Minister of Defence was not limiting his discretion to determine the timing of the LAV project, and to recommend a preferred bidder to Cabinet; and
- (3) communications of the initiative be "low-key".

These conditions are entirely in accordance with the Thyssen proposal and Understanding in Principle. Efforts for their implementation are well underway.

**DEPARTMENTAL POSITIONS:** The Department of External Affairs has no concerns regarding the Bear Head proposal, providing that its stated objective, defence-related production aimed at North American (or NATO) markets and in the long-term, diversification into civilian production, is realized. External Affairs would, however, be concerned, if, in the long-run, with these markets, the Bear Head facility was not commercially-viable, and as a result, petitioned the Government to allow military exports into markets prohibited under Canada's export control policy. In this regard, External Affairs cautions that Thyssen's entry to U.S. military vehicle markets is by no means assured, because the U.S. Department of Defense has historically purchased its vehicle requirements almost exclusively from domestic sources.

3/4

The Department of Finance is concerned that if Ministers sign the Understanding in Principle, the Government will be entering into a de facto commitment, and moreover, a commitment not supported by a business plan. Finance is also concerned that if Ministers wish to enter into such a commitment, that a source of funds, from existing resources, be identified.

The Department of Regional Industrial Expansion is concerned that within its reference levels, funding for major projects, including Thyssen, is unavailable. On industrial policy grounds, DRIE cannot support the establishment of the Thyssen facility because the Thyssen project would exacerbate existing excess capacity in Canada, in the heavy fabrication including the, military-vehicle sector.

DND  
2(1)

The Department of National Defence is preparing documentation to meet the requirements of the position adopted by Mr. Beatty in his discussions with Senator Murray and Mr. Burney on September 14, 1988, as summarized on page 5. Mr. Beatty has agreed to sign the Understanding in Principle, on the understanding that he is acting in accordance with his commitment to the Minister of Finance, concerning the funding of future defence projects.

(1)

TIMING: Thyssen must establish shortly a manufacturing facility in North America to be in a position to win -- in conjunction with its partner, General Dynamics -- a portion of an upcoming U.S. Department of Defence procurement of armoured vehicles, valued at about \$750 million (U.S.). Moreover, the U.S. government plans to proceed with a massive procurement of armoured vehicles, valued at some \$200 billion, for which Thyssen, at Bear Head, would be eligible to compete, under the Canada-U.S. Defence Production Sharing Agreement.

From the Government's perspective, the Thyssen proposal has been developing for some time. Given the timing of the U.S. project, if Ministers wish to support the establishment of the heavy-industry facility at Bear Head, a decision to proceed further will have to be reached soon.

FINANCIAL IMPLICATIONS: Thyssen is not applying for government assistance at this juncture, and any such application cannot proceed without a formal business plan. Moreover, in the absence of a business plan for both Phase I and Phase II, the ultimate draw on (and profile of) government funding, arising from the Bear Head project, is very difficult to determine.

13-C

However, should the Bear Head project proceed as envisaged, including Phase I and Phase II, federal Government assistance could be as high as \$50 million, over at least three years, beginning in 1989/90. The province of Nova Scotia, in addition to land, would provide a further \$8 million, as its share of the common user infrastructure.

52  
4/2

A source of funds for the federal assistance has not been identified, and must be developed prior to Thyssen's submission of a formal business plan and application for funding.

It will be necessary to agree with the Government of Nova Scotia to augment the approximately \$11 million in funds currently available in the Strait of Canso Industrial Development Agreement, which be used as an instrument and a partial source of funds to provide the infrastructure assistance. This funding would come from the Atlantic Cooperation (ERDA) funds notionally set aside.

Funding under the Defence Industry Productivity Program (DIPP), which historically has not been a particularly active program in Atlantic Canada, is not available within existing DRIE reference levels. Further, Atlantic Enterprise Program funding, delivered by DRIE, is also not available within existing DRIE reference levels.

Additional funding for this project must eventually be considered within the broader issue of how -- following the expiration of the IRDF -- the Government is to provide assistance to industrial projects in Atlantic Canada, valued at greater than the \$20 million ceiling for ACOA participation.

EVOLUTION OF THE THYSSEN PROPOSAL: Since Thyssen's original request in 1985, the Federal Republic of Germany has revised its armaments exports policy to allow for specific arms exports from Germany to the Middle East. Accordingly, the current proposal by Thyssen is entirely independent of domestic German exports policy.

RELATED ISSUES: In the course of responding to the Thyssen proposal, Ministers may wish to weigh the following considerations:

15. 11/85

Suitability of the Thyssen vehicle for DND: The operational and technical requirements for the LAV vehicle must be determined solely by DND, and, as noted in the Understanding in Principle, Thyssen will be required -- as will other potential contractors -- to satisfy fully these operational requirements prior to being considered for participation in the LAV project. Forseen for the early-to-mid 1990s. While Thyssen has consistently maintained that it will be able to meet DND requirements, DND officials observe that Thyssen does not currently manufacture a vehicle which meets the operational requirements envisaged for the LAV project.

134

Support of the Government of Nova Scotia: Thyssen has already entered into an agreement with the Government of Nova Scotia regarding the provision of land, and provincial site establishment assistance.

Creation of additional Canadian military vehicle production capacity: While there is no question that the Bear Head heavy-industry facility would add to Canada's existing industrial capacity in this sector,

33  
43

20(4)

now comprising primarily the GM plant in London, Ontario, (and also potentially including FMC, Canadian Foremost, Lavalin, Bombardier, and so on) the proposed arrangement with Thyssen for participation in the LAV contract would not exclude others -- including GM -- from participating as well. Moreover, when diversification into civilian production occurs, the Bear Head facility would contribute greatly to the industrial base of Atlantic Canada, and create a facility capable of competing for military vehicle contracts -- and in other civilian markets -- in the U.S. On the contrary, in order to establish an Atlantic facility, GM, so far, has sought directed, sole-source, military contracts on a single-product-facility basis, with little of the regional or other industrial diversification benefits of the Thyssen proposal.

Consistency of the "Understanding in Principle" and the Government's procurement policy: The Government would stress from the beginning that while Bear Head would be considered for participation in the LAV contract, the proposed arrangements in no way constitute sole sourcing, nor guaranteed participation, and that the fundamental principles of operational requirements and competitive pricing are protected fully.



**NEXT STEPS:** Should Ministers wish to contemplate a regional development proposal of this kind, the following course of action could be pursued:

September 1988

- immediate finalization of the Understanding in Principle; and
- agreement on, and signature of, the Understanding in Principle by involved Ministers.

34  
44

Fall 1988

- formal, detailed negotiations between key federal departments (ACOA, DRIE, PND, Supply and Services) and the company to develop fully a corporate business plan and assistance package;
- concluding negotiations between the federal Government and the Government of Nova Scotia on the common-user infrastructure arrangements;
- preparation of a formal Memorandum of Understanding between the Government of Canada and Bear Head Industries Ltd.;
- formal submission of a Memorandum to Cabinet to CCERD;
- the signing of a formal contractual, legally-binding agreement between Bear Head and the Government.





UNDERSTANDING IN PRINCIPLE

This document signed this 27 day of September, 1988,  
between:

THE GOVERNMENT OF CANADA, as  
represented by:

i) the Minister responsible for  
the Atlantic Canada Opportunities  
Agency (hereinafter called "the  
ACOA Minister"),

ii) the Minister of Regional  
Industrial Expansion (hereinafter  
called "the DRIE Minister"), and

iii) the Minister of National  
Defence (hereinafter called "the  
National Defence Minister); and

BEAR HEAD INDUSTRIES LTD., a  
company incorporated under the  
laws of Nova Scotia, a subsidiary  
which is one hundred (100%)  
percent owned by Thyssen  
Industries A.G. of the Federal  
Republic of Germany (hereinafter  
called "the Company").

WHEREAS the Government of Canada desires  
to foster the economic expansion and industrial  
development of Cape Breton;

WHEREAS the Company must have in place a  
North American heavy-industry manufacturing facility on  
an urgent basis, and desires to establish such a  
facility in the Bear Head peninsula region of Cape  
Breton;

WHEREAS the Government of Canada  
recognizes that the proposed Bear Head facility  
represents an important economic development and  
diversification of the industrial base of Cape Breton;  
and.

WHEREAS the Company is preparing financial details on its proposal, to meet the information requirements of the Government's established regional development capital contribution, and other assistance programs:

1. In accordance with this Understanding in Principle, the Company shall establish a diversified heavy-industry manufacturing facility in the Bear Head region of Cape Breton, Nova Scotia, which will:

(a) create in Cape Breton a new and diversified activity in the Canadian civilian and defence industrial base, with access to the North American defence markets, under the Canada U.S. Defence Production Sharing Agreement;

(b) transfer to the facility, all technology necessary for the construction of light armoured vehicles, and other heavy-industry products;

(c) source its requirements co-operatively from, and implement arrangements for joint-venture activities with, the Lavalin (UTDC) heavy-industry facility, in Trenton, Nova Scotia, in accordance with existing agreements between the Company and Lavalin;

(d) to the greatest extent possible, source its requirements from, and promote the establishment of, small business enterprises located in Atlantic Canada;

(e) implement arrangements for co-production with Krauss Maffei, in accordance with existing agreements between the Company and Krauss Maffei, if, under the Main Battle Tank project envisaged by the Government of Canada, Krauss Maffei is selected to manufacture Canada's replacement battlefield tanks; and

(f) employ a minimum of 500 people on a permanent, full-time basis and, where necessary, train these individuals in required skills and knowledge, utilizing, where appropriate, local educational facilities.

2. In accordance with this Understanding in Principle, the Government of Canada, in order to facilitate the establishment of the Company's heavy-industry manufacturing activity in Cape Breton, will:

(a) enter into negotiations with the Province of Nova Scotia, in accordance with existing letters to the Company from the Premier of Nova Scotia, to put in place financial arrangements for the co-funding of required physical infrastructure, up to a maximum value of \$27 million, and to use the Strait of Canso Industrial Development Subagreement as a source of funding;

(b) entertain an application by the Company to the Minister of National Revenue for assistance based on eligible project costs up to a maximum of \$68 million, under the provisions of the Cape Breton Investment Tax Credit, in accordance with the formal application for such assistance filed by the Company prior to June 30, 1988;

(c) entertain an application by the Company to the Minister of National Revenue for duty remission on the importation of machinery, parts, and components for the manufacturing of vehicles, under the Machinery and Equipment Tariff Program, consistent with this program at the time of such importation; and

(d) entertain an application by the Company to the Minister of Employment and Immigration for government participatory funding, for initial employee training.

3. In recognition of the need to proceed urgently, the Government of Canada and the Company agree to adopt a two-phased approach to the establishment of the Bear Head facility.

#### PHASE I

4. The Government of Canada and Company agree that in Phase I, the respective parties will undertake the following:

(a) the Company:

(i) the Company will proceed forthwith with the construction of an initial plant, as described in the document submitted to ACDA in March 1988, requiring an initial capital investment of \$58 million, to manufacture defence products for the North American markets;

(ii) the Company will have submitted a formal application to Enterprise Cape Breton, in advance of June 30, 1988, seeking assistance under the Cape Breton Investment Tax Credit (CBITC); and

(iii) the Company will provide by October 21, 1988, financial and other details associated with Phase I, and, in the shortest time possible thereafter, the remaining information required in order to qualify for assistance under the Defence Industries Productivity Program (DIPP), and other government assistance programs, under which funding is sought.

(b) the Government of Canada:

(i) the ACOA Minister, and the DRIE Minister, will consider assistance to the Company, up to a maximum of fifty (50) percent of eligible project costs, under programs delivered by Enterprise Cape Breton, consistent with these programs at the time the Bear Head project becomes eligible for such assistance.

(ii) The Minister of National Defence, in recognition of the excellent international reputation for quality and performance earned by Thyssen Industries A.G. in the military vehicle sector, and in the context of the major acquisition program for the upgrading of the Canadian Forces envisaged in the Defence White Paper, will consider the participation of the Company in the Light Armoured Vehicle Procurement Program, envisaged to occur in the early-to-mid 1990's, provided the Company:

(a) develops, designs, and manufactures, in its Cape Breton facility, these vehicles from its entire technology range according to the operational requirements of the Government of Canada,

(b) meets the Government's requirements for quality, delivery, and logistic support, including personnel training,

(c) delivers and performs at internationally competitive prices, and

(d) provides acceptable regional and industrial benefits; and

(iii) the DRIE Minister will consider capital establishment assistance to the Company, under the Defence Industries Productivity Program (DIPP), consistent with this program at the time the Bear Head project becomes eligible for such assistance.

PHASE II

5. The Government of Canada and Company further agree that in Phase II, the respective parties will undertake the following:

(a) the Company:

(i) the Company will proceed not later than twelve (12) months after the commencement of production under Phase I, with diversification into heavy civilian manufacturing production targeted at Canadian and international markets;

(ii) the Company will provide within six (6) months after the commencement of production under Phase I, financial details including product and market projections associated with Phase II; and

(iii) should Phase II not be proceeded with, the Company will reimburse the Government of Canada for:

- (1) assistance as is provided by the ACOA and DRIE Ministers under paragraph 4 b(1) above, and
- (2) a portion, to be determined in subsequent negotiations, of the infrastructure assistance provided under paragraph 2 (a) above, in the event that the planned employment level of 400 people for Phase I is not sustained for 5 years.

(b) the Government of Canada:

the ACOA Minister, and the DRIE Minister, will consider assistance to the Company, under established regional and industrial development programming, consistent with such programs at the time the Bear Head project becomes eligible for such assistance.

6. This Understanding in Principle may be complemented by future Memoranda of Understanding.

7. The understandings in principle set out in this Understanding in Principle do not create any enforceable, legal or equitable rights, nor obligations, but merely serve to document the:

- (a) parameters that have been set; and
- (b) areas on which discussions have been held, and understandings in principle reached.

Further clarifying negotiations and the requisite approval from all appropriate parties (including without limiting the foregoing, Treasury Board, and the Board of Directors of Bear Head Industries Ltd.) are needed before contractual documentation can be entered into.

THE GOVERNMENT OF CANADA

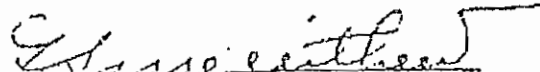
  
Minister responsible for the  
Atlantic Canada Opportunities Agency

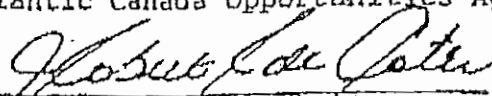
  
Minister of Regional Industrial  
Expansion

  
Minister of National Defence

BEAR HEAD INDUSTRIES LIMITED

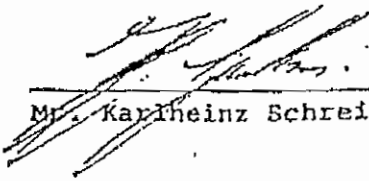
  
Mr. Karlheinz Schreiber, Chairman





94-34-57

 Atlantic Canada  
Opportunities Agency

Agence des perspectives  
de l'Atlantique Canada

To / Pour: D.S. McPhail Date: 9.6.89  
Cc: Norman Moyer

Subject / Objet: Proposed GM Contract, and its  
implications for Bear Head Industries

From / De: Wynne Potter  
Paul Bernier

Your Signature / Votre Signature  
 For Comments / Observations  
 Information  
 Material for the Minister / Documents pour le Ministre

Remarks / Remarques

cc

Drafting officer / Rédacteur: John McDowell



602326

DRAFT "C"

MEMORANDUM

TO: The Honourable Elmer MacKay

FROM: D.S. McPhail

SUBJECT: Proposed GM Contract, and its Implications for Bear Head Industries

The purpose of this note is to brief you on a forthcoming request to Cabinet by the Minister of National Defence to award, on a sole-source basis, a military vehicle contract to General Motors (GM), and to review the implications of such a decision for Bear Head Industries.

We understand that this initiative is likely to be discussed on June 21 by the Cabinet Committee on Foreign and Defence Policy.

The essence of the issue is the following:

A decision to award the vehicle contract to GM would result in meaningful high-quality industrial benefits for Atlantic Canada. Nevertheless, the contract is the last light armoured vehicle contract that DND expects to bring forward for at least the next five years.

This is not to suggest that Mr. McKnight, or indeed other Ministers, would gladly forgo awarding this contract to GM, and award it instead to Thyssen. Indeed, a primary reason for awarding the contract to GM is to ensure that the company retains an armoured vehicle manufacturing facility in London, rather than moving this production -- and some 350 jobs -- to a U.S. location.

However, as you are aware, the much larger light armoured vehicle contract for which Thyssen had been bidding has effectively been cancelled as a result of the Budget. Thus, of the remaining military vehicle

.../2

contracts to be awarded by Canada in the foreseeable future, the contract that Mr. McKnight is seeking to have awarded to GM is the only military vehicle contract proceeding right away, and -- because the contract is for armoured vehicles -- it is also very likely the only contract in the foreseeable future consistent with the heavy-industry skills and technology which Thyssen proposes to bring to Nova Scotia.

A brief description of the proposed GM contract, including its benefits for Atlantic Canada, is attached as Annex A. In addition, you will find attached a copy of an October 1988 letter by the then Minister of National Defence, Mr. Beatty, providing comfort to GM on the contract award.

As far as the status of the Bear Head proposal per se is concerned, we understand that senior representatives of the company (Karlheinz Schreiber) visited Mr. McKnight on May 17th, on an informal basis, to review the file. The company reports that this meeting was constructive, that Mr. McKnight appeared generally receptive to the company's plans for Nova Scotia, and that the Minister did not indicate that anything was amiss with the LAV project.

However, as the impacts of the Budget for DND's capital requisition plans become increasingly apparent -- in the case of the LAV project, for example, the project office is closing -- Thyssen is gradually realizing that the LAV project may be delayed permanently. Thyssen has not indicated so far whether a cancellation of the LAV program would mean an indefinite postponement for its proposed Nova Scotia facility.

D.S. McPhail

Attachments

DRAFT "C"  
ANNEX A

MILITIA LIGHT ARMoured VEHICLES

CONTRACT SCOPE:

Program cost to DND: \$201.3 million to be funded from within the existing reference levels of DND.

GM contract: up to 199 wheeled vehicles, valued at about \$110 million.

FMC contract: up to 22 tracked vehicles, valued at about \$10 million.

ATLANTIC BENEFITS: Following interdepartmental negotiations last December, GM agreed that, if it received the order, the company would place fifteen percent of the contract value -- approximately \$25 million -- in each of Atlantic and Western Canada. Overall direct Canadian content is to be 60%, and the regional benefits are to be of a high-technology manufacturing nature.

So far, the negotiating objectives with FMC Corporation concerning benefits from the 22-vehicle contract would be similar.

On this basis, and prior to the Budget when DND was still intending to proceed with the larger (Thyssen) LAV contract, ACOA indicated its departmental support for the award to GM.

GM has been quite receptive to Atlantic Canada. At the request of ACOA, the company travelled to Nova Scotia, New Brunswick and Newfoundland to meet with potential suppliers, such as ADIL. GM is hopeful that, once it has established a subcontractual relationship with Atlantic suppliers, these suppliers can be relied upon for future orders.

IMPORTANCE OF THE MILITIA CONTRACT TO GM: GM has informed the Minister of National Defence that, although its Diesel Division facility in London, Ontario, has good prospects for future export sales of armoured vehicles, it nevertheless has no orders to fill its productive capacity in 1989 and 1990. As a result, the parent company -- U.S.-based General Motors Corporation -- has threatened to close the vehicle production arm of

its London plant. If GM wins this order, the 350 current jobs will remain, and an additional 125 jobs will be created. GM informs that currently only about 200 people (including professional staff) are employed.

**BACKGROUND:** DND hopes to acquire 221 light armoured vehicles, and associated support.

The vehicles were originally envisaged for training Canada's militia reserves for duty in Europe. Since the Budget, DND is now stressing that, in addition to training, these vehicles are to be used for territorial defence and international peace keeping.

DND wishes to acquire a mix of wheeled and tracked armoured vehicles (wheeled vehicles are generally more mobile on roads and cheaper to operate, but tracks are essential for some specialized tasks such as engineering (bulldozer-type), armoured vehicles). Accordingly, the military is seeking to acquire approximately 199 wheeled vehicles from GM, and 22 tracked vehicles from U.S.-based FMC Corporation.

June 7, 1989

Minister of National Defence



Ministre de la Défense nationale

October 20, 1988

Mr. G.A. Peapples  
President and General Manager  
General Motors of Canada Limited  
215 William Street East  
Oshawa, Ontario  
L1G 1K7

Dear Mr. Peapples:

Further to my letter of September 26, I am pleased to advise you that the evaluation of the General Motors Diesel Division Unsolicited Proposal for Light Armoured Vehicles has been completed.

As you are no doubt aware by now, officials of my Department met again last week with representatives of the Diesel Division in order to conduct a more detailed review of individual elements of the Unsolicited Proposal and its costs. During these meetings, it was determined that \$175 million for all elements of the proposal is the order of the magnitude of costs required for implementation of the proposal.

The purpose of this letter is to advise you that, on the understanding the 200 Light Armoured Vehicles and all other elements of your proposal can be delivered at a "not to exceed" cost of \$175 million, I am prepared to support the proposal to meet my Department's urgent requirement for Light Armoured Vehicles associated with our Land Reserve Modernization Program. Consequently, it is my intention to recommend to my Cabinet colleagues that a contract award be made to your Company, subject to successful negotiation of specific terms and conditions and total costs by the Department of Supply and Services. I am confident, therefore, that a decision will be taken in sufficient time to ensure the viability of the General Motors manufacturing operation in London and the continuance of its contribution to Canada's defence industrial base.

.../2

96-34-57

- 2 -

I am also forwarding copies of this letter to my colleagues, the Minister of State, Finance, the Honourable Tom Hockin and the Honourable Otto Jelinek, the Minister of Supply and Services who have also agreed to support your proposal.

Sincerely,

*Perrin Beatty*  
Perrin Beatty

C.c. The Honourable Tom Hockin, P.C., M.P.  
The Honourable Otto Jelinek, P.C. M.P.

*Beatty  
Hockin  
Jelinek*







President

President

Head Office  
P.O. Box 6051  
Moncton, N.B.  
Canada E1C 9J8

Siège social  
B.P. 6051  
Moncton (N.-B.)  
Canada E1C 9J8

SECRET

MEMORANDUM

OCT 26 1988

TO: The Honourable Elmer MacKay  
FROM: Peter B. Lesaux  
SUBJECT: Bear Head Industries (Thyssen): Update  
PURPOSE:

To provide a brief status report on the Bear Head Industries (BHI) manufacturing facility planned for Cape Breton, and a proposed letter for your signature to the Minister of Industry, Science and Technology Canada (ISTC).

ACTION REQUIRED:

Your signature on the attached letter to the Honourable Harvie Andre.

BACKGROUND:

The key aspect of the BHI file at this juncture concerns the Cape Breton Investment Tax Credit (CBITC). As you will recall, BHI complied with the June 31, 1988 application deadline under the CBITC program. The company also continues to be mindful of the next statutory CBITC deadline which requires that applicants have assets purchased (and presumably in use) prior to December 31, 1992.

.../2

Canada

000055

3423 0000112

*[Handwritten mark]*

3423 0000112

000056



As part of a general review to identify the aggregate value of the Government's contingent liability under the CBITC program, ISTC officials, at the request of the Department of Finance, are ending the CBITC eligibility of specific Cape Breton projects which have requested tax credit assistance but which appear unlikely to proceed. In this context, the business plan for the Thyssen project, which has been promised for some time, remains outstanding, and ISTC officials are contemplating dropping BHI from future CBITC eligibility.

CBITC assistance -- which could provide BHI up to 60% of eligible project costs through the tax system -- is a key requirement in the company's plans for Cape Breton, and indeed the company is concerned that failure to qualify for CBITC funds could sound the death knell for the project.

BHI is, however, unable to complete its business plan, and thereby remain active under the CBITC program, because the status of the DND light armoured vehicle (LAV) project remains unclear. (The company recently received a response from the Honourable Bill McKnight to its July 19th, 1989 letter concerning the LAV project, and a copy of these letters is attached.)

In this context, the attached letter to the Honourable Harvie Andre -- in drawing attention to your Cabinet-assigned lead role on this project -- seeks to ensure that the BHI project indeed remains eligible for CBITC assistance, pending DND's resolution of its intentions on the LAV project.

On the non-military production front, BHI continues to plan possible production in environmental (waste disposal) sectors. A copy of an October 11 memorandum submitted by the company to ISTC officials is also attached.

**RECOMMENDATION:**

That you sign the attached letter to the Honourable Harvie Andre, Minister of Industry, Science and Technology.

*Peter B. Lesaux*  
Peter B. Lesaux

Attachments

Canada

000057

3423 0000113

*[Handwritten mark]*

3423 0000113

000058

MILITIA LIGHT ARMoured VEHICLES

CONTRACT SCOPE:

Program cost to DND: \$201.3 million to be funded from within the existing reference levels of DND.

GM contract: up to 199 wheeled vehicles, valued at about \$110 million.

FMC contract: up to 22 tracked vehicles, valued at about \$10 million.

ATLANTIC BENEFITS: Following interdepartmental negotiations last December, GM agreed that, if it received the order, the company would place fifteen percent of the contract value -- approximately \$25 million -- in each of Atlantic and Western Canada. Overall direct Canadian content is to be 60%, and the regional benefits are to be of a high-technology manufacturing nature.

So far, the negotiating objectives with FMC Corporation concerning benefits from the 22-vehicle contract would be similar.

On this basis, and prior to the Budget when DND was still intending to proceed with the larger (Thyssen) LAV contract, ACOA indicated its departmental support for the award to GM.

GM has been quite receptive to Atlantic Canada. At the request of ACOA, the company travelled to Nova Scotia, New Brunswick and Newfoundland to meet with potential suppliers, such as ADIL. GM is hopeful that, once it has established a subcontractual relationship with Atlantic suppliers, these suppliers can be relied upon for future orders.

IMPORTANCE OF THE MILITIA CONTRACT TO GM: GM has informed the Minister of National Defence that, although its Diesel Division facility in London, Ontario, has good prospects for future export sales of armoured vehicles, it nevertheless has no orders to fill its productive capacity in 1989 and 1990. As a result, the parent company -- U.S.-based General Motors Corporation -- has threatened to close the vehicle production arm of

000050





Atlantic Canada  
Opportunities Agency      Agence de promotion économique  
du Canada atlantique

# 328

ACOA/APECA  
RECEIVED/REÇU  
MONCTON  
19626  
NOV 8 1989

Minister                      Ministre  
Ottawa, Canada K1A0A4

*File*

Referred to  
File      *2635-T1*  
Dossier: *Secret*

OCT 31 1989

SECRET

The Honourable Harvie Andre, P.C., M.P.  
Minister of Industry, Science and  
Technology Canada  
Room 558, Confederation Building  
House of Commons  
Ottawa, Ontario  
K1A 0A6

My dear *Harvie* Colleague:

I am writing with respect to the Bear Head Industries (BHI) manufacturing facility planned for Cape Breton, and in particular, to ensure that this project remains eligible to receive the Cape Breton Investment Tax Credit.

As you will recall, following consideration by Cabinet of the BHI proposal last fall, the Government signed an "Understanding in Principle" with the company which provided, inter alia, that the company be considered for participation in the Government's anticipated purchase of light armoured vehicles (LAVS). Moreover, the Minister responsible for the Atlantic Canada Opportunities Agency was directed to return to Cabinet with the BHI initiative when this project had developed further.

As you may know, however, following the April 1989 Budget, DND suspended its major planned capital acquisitions, including the LAV program, pending the completion of an overall review of spending priorities -- a review which is still ongoing. As a result, while BHI continues to develop its proposal -- particularly with respect to civilian production -- the company is unable to finalize its business plan, prior to a determination by DND on the scope and timing of the LAV program.

.../2

Canada

000065

I understand that your officials, as part of a general review of several Cape Breton projects which have applied for CBITC funding but which remain inactive, are contemplating recommending that BHI become ineligible for CBITC assistance.

In light of my responsibilities to return to Cabinet with the BHI initiative, and the inability by BHI to complete a business plan pending the outcome of DND's decisions on the LAV program, I would request that the BHI project continue to remain eligible for CBITC assistance.

Yours sincerely,



Wilmer MacKay

000066







## BEAR HEAD INDUSTRIES LIMITED

Suite 908, 350 Sparks Street  
Ottawa, Ont., Canada  
K1R7S8

TELEPHONE(613)563-3321

TELEFAX (613) 563-7648

28 November 1989

PRIVATE AND COMMERCIAL CONFIDENTIAL  
HIS EYES ONLY!

The Hon. Elmer MacKay  
Room 509  
Confederation Building  
House of Commons  
Ottawa, Ontario  
K1A 0A6

Dear Elmer:

I am writing today to explain that I have become so frustrated with the situation around the Thyssen Industrie AG (Thyssen) plan to establish in Nova Scotia that I fear we may be losing the chance to make this project a reality.

At the start of the new year, I must report to the Board of Thyssen on the prospect of Thyssen's participation in any Canadian military vehicle program as a start up for the Bear Head Industries project. Needless to say, their patience for this project is very strained.

In 1985, the Minister responsible for Regional Industrial Expansion explained to Thyssen that Eastern Nova Scotia was the Prime Minister's and the Government's highest priority for economic development and urged the company to invest there. The Prime Minister's interest was obvious given his electoral attachment to Eastern Nova Scotia and the high unemployment rate resulting from the difficulties faced by Sysco, Trenton Works, and the closing of the heavy water plants.

At that time Thyssen was ready to establish a new facility in the United States to gain entry to the large upcoming armoured vehicle



## BEAR HEAD INDUSTRIES LIMITED

2

programs. I was proud to be able to convince Thyssen instead to concentrate their efforts first in Canada and access the US defence market through the Canada-US Defence Production Sharing Agreement and secondly, the civilian market through the pending Free Trade Agreement.

Thus, Thyssen committed itself to making Eastern Nova Scotia the site of a new North American heavy industrial manufacturing base, targeting defence and civilian production. The dimensions of the Thyssen commitment are evidenced by their preparedness to make a capital investment of more than \$68 million with a promise to create 500 jobs.

For Thyssen to justify their abandoning the U.S. as the site for their North American base, they had to have a reason, which could only be having business with DND. At this time, DND had a declared armoured vehicle requirement for some 1600 vehicles, so it appeared quite reasonable to pursue a commitment of a 250 vehicle start-up order. Furthermore, on May 27, 1987, Gen. J. Fox, then Commander of Mobile Command, in public testimony to the Senate Committee on Defence, revealed the desperate need in Canada's army to have armoured vehicles with adequate protection. Additionally, the Prime Minister confirmed that same year to the Canadian Forces in LaBr, that he would give them the right equipment to do their job.

Thyssen has further committed to diversify in the first phase through production of Thyssen's entire range of environmental protection products which have been proven in Europe and the U.S. as state of the art solutions to problems like acid rain causing gas emissions and treatment of municipal solid waste. Market research has confirmed that the Thyssen environmental technology will fit the North American market, and it is ideal as a second product on the manufacturing facility utilizing similar work force skills and production technology.

Much encouragement has been offered to Thyssen, and none stronger than that received from ACOA. Since its very creation, the agency having been mandated by the Prime Minister with specific instructions to "make the Thyssen project happen", immediately assumed the role of advocate for the BHI project and has remained so since. To our knowledge, the Prime Minister's support for the project is has not changed.

In 1988 ACOA's support for the BHI project encountered what was supposed to be the single immovable obstacle to the project, that being the requirement for a sole sourced start-up order to design and build 250 units from DND's then 1600 LAV requirement. At that



## BEAR HEAD INDUSTRIES LIMITED

3

time sole sourced orders, in some quarters were described as contrary to the policy of the Government of Canada.

Later in 1988, Ministers Beatty, Jelinek and Andre announced a sole sourced order in Calgary, for 400 northern terrain vehicles for Canada's Armed Forces, from a Swedish firm and their Canadian partner in Calgary.

This was understood by Thyssen as a change in the previously described policy, on the grounds that this particular sole sourced order benefited a regional economy. This situation encouraged Thyssen because of the commitment made to the Atlantic region.

On September 27, 1988, Thyssen held a press conference in Halifax to publicly announce the BHI commitment to Eastern Nova Scotia at a time when the announcement was requested to show the progress of the Government's commitment to Atlantic Canada. The company was confronted with difficult accusations of making a pre-election announcement, but stood by the announcement in good faith to the Government, having received a document of understanding from the Government which carried the signatures of the Ministers for ACOA, DRIE and DND and symbolizing the intent of the Government toward the BHI project.

In April 1989, the Federal budget brought major cuts to the DND capital budget. However, in July 1989, DND announced a sole sourced order to General Motors Diesel Division of London, Ontario after the company reported in the media that they might have to close down operations on their wheeled armoured vehicle line. Unemployment in that region was 3.3% as of May 1989.

From the standpoint of any logical analysis, the long awaited Force Development Plan (FDP) for the Canadian Forces cannot fail to include the Multi-Role Combat Vehicle (MRCV) requirement. Furthermore, a minimum quantity of 250 vehicles is readily apparent. The actual number will undoubtedly be substantially more. We see examples of major projects proceeding in advance of the FDP: the Arcturus Aircraft; the Maritime Coastal Defence Vessel; and now, IRIS. Hence, why can DND not now proceed with the MRCV which is of such fundamental importance to any and all future army structures?

This series of events has left me at a loss to find any rational explanation to offer to the Thyssen Industrie Board, as to why they should continue their commitment to Canada.



## BEAR HEAD INDUSTRIES LIMITED

4

Five years have past since Thyssen was first invited to place their North American heavy industry production base in Canada, but I hope you can understand that their patience is nearing an end. I doubt that further explanations will retain Thyssen's commitment. The time is here when some concrete commitment is necessary with respect to their participation in the design and construction in Nova Scotia of the next DND armoured vehicle. If something can be done to engage such a commitment, I urge you to do it now as I will be obliged to report the situation as I see it upon my return to Germany next week.

In closing, I would ask you to advise me on two difficult matters.

First, would you be so kind to tell me how I should respond to the continued enquiries about our project from Opposition MP's, the press, and the people in Nova Scotia? I feel, I cannot delay my reply much longer without incurring unnecessary public criticism of Thyssen for "stone-walling".

Secondly, as you know, I am duty-bound to inform the Prime Minister of the serious situation the whole matter has reached. Will you want me to write to him directly or would you prefer to do so on my behalf?

In closing, I thank you for your personal support of the BHI project, and want you to know, I am very sorry we have still not achieved results after so long a time. However, I want you to know that, despite my present concerns, I believe one last concerted effort is worthwhile. The needs of our soldiers, the livelihood of the unemployed in Nova Scotia, and the commitments of our Prime Minister together make it so.

Yours Sincerely,

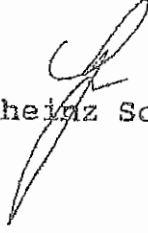
  
Karlheinz Schreiber



# Karlheinz Schreiber

Suite 908, 350 Sparks Street, Ottawa, Ontario  
Telephone: (613) 563-3321 Fax: (613) 563-7648

PRIVATE AND COMMERCIAL CONFIDENTIAL  
FOR HIS EYES ONLY!

29 November 1989

The Hon. Elmer MacKay  
Room 509  
Confederation Building  
Ottawa, Ontario  
K1A 0A6

Dear Elmer:

I just finished the letter you find attached, dealing with the Bear Head Industries (BHI) situation.

Reading this letter, I cannot stay away from sending you another private note on the same subject.

When you think of our lack of progress, it is ironic to look back at the phrases that we started out with in 1984/85, "come to Canada to invest", "Canada is open for business".

The Hon. John Crosbie and dozens of delegations are travelling around the world and especially in Germany to invite companies to invest in Canada. In Germany, I receive an invitation every few weeks from the Canadian Ambassador or the Canadian Counsel General in Munich to attend meetings with these groups. Recently, the Premiers of New Brunswick, British Columbia, Quebec, Mayor of Montreal, Trade Commissioner from Alberta, etc., have all come to Germany with the same basic requests.

Now consider, Thyssen

- one of the largest industrial and high technology companies in Europe
- 130,000 employees worldwide
- extensive diversification,
- extensive international sales,
- some 15,000 employees in the U.S. and;
- almost 2,000 in Canada.

For five years Thyssen has been prepared to carry out exactly what all the aforementioned delegations are asking for.

The main conditions to start the project:

- a start-up order to design and build 250 armoured vehicles to meet the operational requirements of Canada's army,
- support from the Government of Canada on exports to the U.S
- the land and basic infrastructure of road, rail and services.

On the other hand, Eastern Nova Scotia faces high unemployment in light of the difficulties encountered in Sydney, Trenton, Sheet Harbour, and with the close of the Heavy water plants.

Nova Scotians who have left their home Province to find work have written us from all over Canada, to tell us that they would like to return to Nova Scotia if they can find work with us.

The poor Canadian soldiers with inferior equipment, face the danger of being shot on a peace keeping mission even while they are inside their so called armoured personal carriers ( which are of a more than 30 year old design), with no capability to stop 7.62mm (armour piercing) machine gun bullets. This type of ammunition is now used all over the world as standard issue to soldiers. You yourself have seen the samples of how this small bullet pierces through the so called armour aluminum plate, having a thickness of more than one inch.

Canadian soldiers, aboard either their M113 or the AVGP would be wiped out by as common a weapon as the standard artillery shell.

Of course, in light of the changing international scene there is a temptation to delay and delay any decision on acquisitions for the Canadian Armed Forces. But experts starting with NATO's Secretary General confirm that the events occurring in the east bloc are the direct result of NATO's very existence. All are agreed starting with our own Prime Minister that now is not the time to disband or withdraw from NATO.

Let's look at the NATO partners and the moves they are making to acquire vehicles with a multi-role combat capability for their forces. The British have launched their program for 7,500 vehicles, the Norwegians for 400, the Swiss for 400, the French have a new requirement for 2,000, the Americans have a broad range of vehicle programs that reach \$200 billion in value. As I mention the Swiss, with their reputation of a neutral country, not only are they buying these 400 heavily protected vehicles, they do this having just held a national referendum which decided 2 to 1 in favour of retaining their armed forces.

NATO nations together are facing the need to devote their attention and resources to equip their armed forces with a multi-role vehicle



that will allow them to carry out their role in peace-keeping as well as maintaining the ability to serve other roles such as territorial defence.

No NATO nation needs such a vehicle more than Canada, the recognized leader among all NATO for our peace-keeping role. In short, Canada needs a single modern vehicle which can be used in a variety of roles from NATO to peace-keeping while providing an adequate degree of protection in each scenario.

This is exactly the vehicle concept which Thyssen has proposed to develop and build in Nova Scotia for Canada's Forces and for the United States.

Canada is finding a lead role in the international scene with efforts to protect the environment. Thyssen is regarded as a world leader in environmental protection technology, in particular with their scrubbers which stop acid rain causing sulphur dioxide. Thyssen's environmental systems are the first priority among their broad range of non-military technology which Thyssen have committed to the production line at Bear Head Industries.

To me there seems an obvious opportunity for Nova Scotia; just consider the following :

- Coal is an essential part of the economy in Nova Scotia, as well as New Brunswick and British Columbia,
- mining coal provides essential employment,
- Coal's major use is for fuel in thermal power generating,
- the power generated serves the domestic market and can be a valuable export as is envisaged by the Blue Nose Project of Nova Scotia Power.

If we simply burn coal we will continue to release into the environment, acid rain causing sulphur dioxide and nitric oxide, unless power stations are fitted with scrubbers. Thyssen want to produce those very scrubbers in Nova Scotia for Canada and for export.

Why shouldn't we build the technology in Canada which will solve coal's impact on the environment and give coal a continued future as a safe energy source.

Every Canadian taxpayer must be frustrated with the constant losses they see through industrial development programs of grants which have left a trail of industrial tombstones. Grants are not a foundation for success. What is required to assure success is technological expertise, internationally competitive capability, and new private investment.

Thyssen has proven this by its annual return of increasing profits.

A healthy industrial infrastructure has to emerge in Atlantic Canada, and Thyssen is prepared to make their contribution to that infrastructure.

Here we sit in BHI, having spent well over \$2 million on travel, office operations, staffing, etc, having seen all the efforts you have made championing this project with the support of the Prime Minister, and nothing has yet been accomplished.

So, I ask what is going on in our country?

Is it really necessary that a company from abroad with the intention to place a substantial investment in Canada must first give a controlling share of its own company to a U.S. company and locate in Ontario to make it work. By this, you know, I refer to the "shotgun" marriage" orchestrated by DRIE officials between Thyssen and General Motors. Is this the Canadian Sovereignty we have to protect so badly?

On top of this history, you are also aware that we are in competition in the U.S. to supply our NBC Fox vehicle to the U.S. Army. Our teaming partner is General Dynamics and if we win this project and can establish BHI in time, we will bring the Fox hull fabrication to Nova Scotia. The competition to this bid in the U.S. is General Motors teamed with TRW. We have learned that the technical evaluation team has recommended our Fox vehicle for selection, and last week, this information appeared in Washington's defence media. Now we are finding that the champion of an assault on the Thyssen selection is none other than the Canadian Embassy. This seems to suggest that our intention to bring jobs to Nova Scotia is less valued than the interests of Ontario.

Elmer, I truly cannot believe that the Prime Minister with his busy schedule is aware of what is really going on with and around the project. What is going on here hurts the Prime Minister's reputation and is damaging the interest of the Canadian people.

If it is in the interests of the Government to see the Bear Head Industries plant come into being with its associated jobs in construction, engineering, production, etc, then I must draw your attention to the attached "shortest time schedule for development and production" of this new multi-role combat vehicle.

I am really scared that Thyssen could give up on this project and the story of what happened over the last 5 years will come out in public. For sure, then the Canadian Government can save a lot of money by not sending Government delegations to Germany to invite investment, because they will not be taken seriously.

Consider the impact this would have on Canada's target for further sales to Germany's Armed Forces for Challenger jets, reconnaissance drones, etc.

Elmer, you for sure, are the best advocate to witness Thyssen's and my personal patience in this matter, but it comes to an end.

I would ask you to think my letter through and advise me whether you prefer to discuss the matter with the Prime Minister yourself or for me to write to him directly.

Yours very truly,

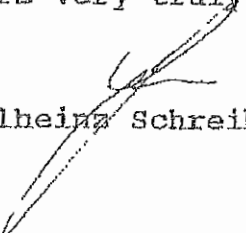
  
Karlheinz Schreiber

SHORTEST TIME SCHEDULE for BHI/TH 495  
DEVELOPMENT and PRODUCTION

	1/90	1/91	1/92	1/93	1/94	1/95
1. CONTRACT	0	4	12	18	24	30
2. PROTYPE DEVELOPMENT	0	4	12	18	24	30
3. PRODUCTION OF 1st PROTOTYPE (PT 1)	0	4	12	18	24	30
4. MANUFACTURER'S TESTS (PT 1)	0	4	12	18	24	30
5. MILITARY TESTS (PT 1)	0	4	12	18	24	30
6. PRODUCTION OF 2nd 3rd PROTOTYPE (PT 2-3)	0	4	12	18	24	30
7. MANUFACTURER'S TESTS (PT 2)	0	4	12	18	24	30
8. MILITARY TESTS (PT 2)	0	4	12	18	24	30
9. MANUFACTURER'S TESTS (PT 3)	0	4	12	18	24	30
10. DEVELOPMENT and TEST OPERATING MANUALS	0	4	12	18	24	30
11. DEVELOPMENT MAINTENANCE MANUALS	0	4	12	18	24	30
12. TEST LOGS/TC with (PT 3)	0	4	12	18	24	30
13. RECEPTION of TEST RESULTS	0	4	12	18	24	30
14. PROCUREMENT of LONG LEAD ITEMS	0	4	12	18	24	30
15. DELIVERY of LONG LEAD ITEMS	0	4	12	18	24	30
16. COMPLETE SPIRE PRODUCT	0	4	12	18	24	30
17. DEVELOPMENT of FIRST VEHICLE	0	4	12	18	24	30
18. FINAL PLANT ENGINEERING	0	4	12	18	24	30
19. SITE WORK	0	4	12	18	24	30
20. PLANT CONSTRUCTION	0	4	12	18	24	30
21. INSTALLATION TOOLS, ELECTRICITY etc.	0	4	12	18	24	30
22. TRAINING NEW PEOPLE	0	4	12	18	24	30
23. TRAINING SENIOR PEOPLE	0	4	12	18	24	30
24. START NEW-PRODUCTION PLANT	0	4	12	18	24	30
25. START EMPLOYMENT STAFF	0	4	12	18	24	30



Minister of Regional  
Industrial Expansion



Ministre de l'Expansion  
industrielle régionale

*File*

- 1. P. B. Leamy
- 2. J. P. Blanchard
- 3. W. P. Lister

The Honourable L'honorable  
Harvie Andre P.C. M.P.

*Moncton in response  
cc David J.  
DR 7 dec 89*

DEC -4 1989

The Honourable Elmer MacKay, P.C., M.P.  
Minister Responsible for the  
Atlantic Canada Opportunities Agency  
House of Commons, Room 509-COFP.  
Ottawa, Ontario  
K1A 0A6

ACOM/PECA  
RECEIVED/RECU  
MONCTON  
20169  
DEC 8 1989

Referred to: *Free*  
File No: 2635-T1  
Date: \_\_\_\_\_

My dear Colleague:

Thank you for your letter of October 31, 1989, concerning Bear Head Industries and the Cape Breton Investment Tax Credit Program.

Officials of my department have been negotiating with this company for many months concerning their request for assistance and are fully cognizant of the difficult position that the company finds itself in with respect to the light armoured vehicles program.

I recognize your responsibilities to return to Cabinet with the Bear Head Initiative, and the key position that my department has in this matter. I have therefore instructed my officials to defer making a recommendation concerning the company's request for assistance until Bear Head Industries has had time to further develop its proposal for the manufacturing facility.

Yours sincerely,

*Harvie Andre*  
Harvie Andre

MINISTER'S OFFICE  
A. C. O. A.

DEC 7 1989

3700-6  
BUREAU DU MINISTRE  
A. P. E. C. A.

Ottawa, Canada K1A 0H5





Atlantic Canada  
Opportunities  
Agency

Agence de  
promotion économique  
du Canada atlantique

President

Président

Head Office  
P.O. Box 8051  
Moncton, N.B.  
Canada E1C 9J8

Siège social  
B.P. 8051  
Moncton (N.-B.)  
Canada E1C 9J8

MEMORANDUM

JAN - 4 1990

TO: The Honourable Elmer MacKay  
FROM: Peter B. Lesaux  
SUBJECT: Attached Letter to Thyssen

Attached for your signature is a letter to Thyssen Industrie AG, on behalf of the Government of Canada, reaffirming the Government's support for the company's heavy-industry facility proposed for Cape Breton.

The letter proposes to the company that the facility be based primarily on environmental production, and suggests that, if the company agrees with this approach, the Government would work immediately to assemble a package of assistance.

We believe in the current environment, there are excellent prospects for the development, with government support, of a facility focused on environmental technologies. Moreover, the establishment of a leading-edge-technology environmental facility in Cape Breton would be a very significant step in support of the Government's Environmental Agenda.

Should the company agree with the proposed environmental approach, several areas will require our immediate attention, specifically:

- a more precise identification of the scope of the environmental marketplace;
- the best way of ensuring that such an industrial initiative can compliment fully the Environmental Agenda of the Government; and

MINISTER'S OFFICE  
A. C. A.

Canada

JAN 5 1990

3700-6

BUREAU DU MINISTRE



what government incentives might be available, and what specific measures might be taken by the federal government, possibly in conjunction with provincial governments.

In response to the first of these areas, identifying the environmental marketplace, we have had very preliminary discussions with officials at Environment Canada and ISTC. Moreover, Bear Head Industries (with ACOA Action Program support) has commissioned a major consultant's report on the environmental market, and a draft will be available shortly. However, further analysis will be required, and ACOA officials will meet urgently with key federal officials, and I would propose also, with appropriate representatives of the New Brunswick and Nova Scotia governments.

With respect to the military light armoured vehicle contract that Thyssen is pursuing -- and which comprised the key element of the "Understanding in Principle" signed last September -- we have been informed by the Deputy Minister of DND that DND will not be proceeding with any LAV contract (or any comparable equipment which could be supplied by Bear Head) for the foreseeable future.

You will recall that a satisfactory business plan has never been received from Thyssen, due in large part to the inability of the company to plan its key military production. Accordingly, the letter to Thyssen does not refer at all to a military market or contract, but simply notes the Government's interest in seeking to orient the company towards environmental production in Cape Breton.

As a separate matter, while the Cabinet decision directing the signing of the "Understanding in Principle" also established the ACOA Minister as the lead Minister on the ACOA file, nevertheless, the proposed letter to Thyssen may very well be interpreted as a formal communication to the company by the Government. [In this context, therefore, you may wish to speak informally with the Prime Minister, prior to its signing.]

39(a)(c)(d)

.../3

Canada

2

Mr. Werner Bartels, the addressee, is a close colleague of Mr. Schreiber, and is the Chairman of the Executive Board of Thyssen Industrie AG, the parent company of Bear Head Industries. We understand that the approval of the Executive Board would be required for Thyssen to decide to locate in Cape Breton on the basis of environmental technology. Mr. Bartels has visited Cape Breton, and while not involved with the day-to-day operations of Bear Head Industries, or indeed Thyssen, is known to be supportive of the Cape Breton project.



Peter B. Lesaux

39(b)(d)

[ Minister: Inasmuch as this is a very sensitive file, and has been the subject of much discussion both in cabinet and amongst officials, I believe it imperative that you speak with the Prime Minister and/or Mr. Stanley Hartt to apprise them of your intentions. ] As the letter quite properly states, you are pursuing an important initiative on behalf of the Government of Canada.

Canada

3



Minister                      Ministre

Ottawa, Canada K1A 0A4

Dr. -Ing. Werner Bartels  
Chairman of the Executive Board  
Thyssen Industrie AG  
Am Thyssenhaus 1  
4300 Essen  
Federal Republic of Germany

Dear Mr. Bartels:

I am writing, on behalf of the Government of Canada, to reaffirm the Government's strong interest and support for the establishment, by Thyssen Industrie AG, of a major manufacturing facility in Cape Breton, Nova Scotia.

As Thyssen has acknowledged, such a facility will significantly increase Thyssen's manufacturing base in North America, and will allow the transfer of investment and leading-edge technology to Canada to supply commercial and other markets. Moreover, by locating in Cape Breton, Thyssen will benefit from access to world trade routes, proximity to central Canadian and northeastern American markets, a skilled labour force, and be eligible to receive assistance under a number of government programs.

As you know, Thyssen and the Government of Canada have been engaged in discussions in recent years, leading to the "Understanding in Principle" reached by the Government and the Company in 1988, and the submission of a preliminary proposal by Bear Head Industries this past summer.

I have noted with satisfaction that Bear Head Industries has consistently cited the production of environmental protection equipment as one of the prime markets to be pursued. As Canada enters the 1990s, responsible stewardship of the Canadian and international environments is a key priority for Canadians, and for our Government.

.... /2

Canada

4

Indeed, the market for the production of environmental protection equipment in North America is emerging as one of the most significant commercial growth areas in the foreseeable future. The opportunities for your firm, with its extensive experience in leading markets in the environmental field, should be particularly attractive.

Accordingly, to advance the Bear Head proposal, the Government of Canada would like to encourage Thyssen to orient its business plan toward a production facility in Cape Breton which would be targeted largely at environmental markets. Should Thyssen wish to pursue such a manufacturing facility, the Government is prepared to lend its support to this decision, and to begin work immediately to assemble a package of assistance. I would like to reassure Thyssen, in this context, however, that should the company choose to pursue an early environmental orientation for its Cape Breton facility, this course of action would in no way compromise the company's access to other markets or production areas in Canada now or in future under consideration.

I look forward to hearing from Thyssen Industrie AG following its consideration of this matter.

Yours sincerely,

Elmer MacKay

c.c.: Mr. Winfried Haastert



PCO - FPRO - BCP - BRFP
Original: 3.7.40.2
Copies:
Ident:

SECRET

R. Protti  
R. Bildeau  
J. Billings  
Circ  
Chron  
Subject  
PCO Files

NOTE FOR OPERATIONS COMMITTEE

January 22, 1990

Item Atlantic Report: Overview of Key Issues and Projects

ISSUE

The following is an inventory of key files affecting Atlantic Canada. It is intended only to review the decisions that are pending and the decision-making processes under way.

MAJOR FILES:

1) NORTHERN COD

Issue/Pending Decision: Development of a package of long-term measures related to restructuring of the fishery and rebuilding the resource base. In the short term, the Harris Committee will report to Mr. Siddon in early February. Harris is likely to recommend major changes to fisheries management practices and a lower quota for 1991, implying further plant closures. Public discussion will begin on the credibility of DFO science, the need for further conservation and future TAC levels.

Process: Ad-hoc Committee to meet January 23 to consider long term restructuring package. Detailed program design and negotiations with provinces will follow. Consultations with industry and provinces on fisheries management, the science issues raised by Harris and rebuilding the resource base should lead to federal action by mid-summer.

2) UNEMPLOYMENT INSURANCE ACT AMENDMENTS

Issue/Pending Decision: resolution of impasse with the Senate over passage of C-21. The impact of the impasse on individual claimants has been minimal and would not be felt unless the impasse is not resolved for four or five months. CEIC has special measures in place to protect the entitlements of fishermen but has not publicized them.

3740-2 Vol 2 Opz 1

PCO.SCH\_INQ.HQ\_LO.MUL.16.0001.00  
08

Process: Discussion by the Operations Committee. The Government has indicated to date that it would not amend its legislation, pending receipt of Senate report, perhaps by end of January.

3) BASE CLOSURES: SUMMERSIDE AND CHATHAM

Issue/Pending Decisions: public and private sector initiatives to generate alternate employment or uses of bases.

Process: Ad-hoc Committee on Base Closures active since July, 1989. Regular CEIC and ACOA programs are being used. Summerside: consultant's report on potential private sector initiatives is due in late January. ISTC is negotiating with P.E.I. and Cavendish Farms (Irving's) for a major potato processing plant (SEE ITEM 9 BELOW). Potential federal jobs centre on the unresolved configuration and location of permanent GST facilities to be established in 1993. An announcement is pending that Ottawa will serve as the interim centre. Chatham: consultant's report on conversion to civilian airport due in April.

4) THYSSEN (Bear Head, Cape Breton Island)

Issue/Pending Decision: go-ahead from federal government and German parent company. Thyssen proposes to build a manufacturing plant at Bear Head. However, before a final decision, the company must complete a viable business plan for non-military products and the Government must resolve the level and source of federal funding.

Process: ACOA has funded a study by Price Waterhouse examining potential market for non-military products, especially scrubbers for thermal power plants. Preliminary results may be available in early February. Mr. MacKay proposes to write to the parent company to invite early discussions.

5) WESTRAY (Pictou County, Nova Scotia)

Issue/Pending Decision: final details of loan insurance and interest rate buy-down assistance prior to announcement. Issues include whether assistance will flow to Westray or its parent, Curragh Resources. Contract between Nova Scotia Power Commission and DEVCO has not been signed.



3740-2 Vol 2 Opw1

PCO.SCH\_INQ.HQ\_LO.MUL.16.0001.00  
08

Process: approved by P&P in December and written offer accepted by company. Final announcement could be ready in two or three weeks.

6) POTATO PROCESSING PLANT (Summerside, P.E.I.)

Issue/Pending Decision: level and source of federal funding for Cavendish Farms (Irving) project. ACOA, CEIC, ISTC and Agriculture would share the \$25 million cost from existing resources. McCain objects strongly and is raising possible U.S. countervail.

Process: to be discussed by the Operations Committee on January 22.

7) HIBERNIA (Newfoundland)

Issue/Pending Decision: final binding agreements needed before June 30. Key issues are allocation of industrial benefits and an operating agreement among the private sector owners.

Process: Ad-hoc Energy Committee met January 18 on a federal negotiating strategy on industrial benefits. Mr. Epp is to meet Premier Wells as soon as possible to discuss industrial benefits. If a common approach can be found, the two governments would then meet Mobil. If not, Mr. Epp will report back to the Ad-hoc Energy Committee.

8) GOOSE BAY NATO BASE

Issue/Pending Decision: whether Canada will actively continue its bid for the NATO tactical fighter centre, which is under review by NATO. If Canada withdraws its bid, it may jeopardize activity under existing international agreements, which is the economic mainstay of Goose Bay.

Process: review of options by Cabinet Committee on Foreign and Defence Policy on February 7.

MEDIUM AND LONGER TERM ISSUES

9) P.E.I. FIXED LINK

Issue/Pending Decision: completion of environmental review prior to final go-ahead, including selection of prime contractor.

3740-2 Vol 2 Open

PCO.SCH\_INQ.HQ\_LO.MUL.16.0001.00  
08

Process: EARP review under way with public hearings scheduled for February/March. Final report due in April/May.

10) NEW BRUNSWICK HIGHWAYS

Issue/Pending Decision: Premier McKenna's repeated demands since 1988 for up to \$1.4 billion to upgrade highways, particularly the Trans-Canada.

Process: Mr. B. Bouchard to bring recommendations to Cabinet in 1990 on a National Highways Strategy, preferably in the context of a strategy on the different modes of transportation. An MC may not be ready before the summer recess. Total national demands for federal assistance to highways are estimated at \$17 billion. In the longer term, the Royal Commission on National Passenger Transportation could make relevant recommendations in an interim report due in 1991.

11) FUTURE OF DEVCO AND ENTERPRISE CAPE BRETON

Issue/Pending Decisions: DEVCO has just signed a four year labour contract, providing prospect of stability. DEVCO could be ready in February to announce that the Lingan colliery will introduce retreat mining. This is a sensitive local issue because this alternative method has been called for in order to extend the life of the mine. Funding has to be finalized in the Main Estimates. Options for the future of Enterprise Cape Breton are under review.

OTHER ISSUES

12) MAGNA:

Mr. Andre will report on Magna's increasing losses at its Sydney, Nova Scotia plant. Current employment is 150.

Wernick/da

3740-2 Vol 2 Op 1

PCO.SCH\_INQ.HQ\_LO.MUL.16.0001.00  
08



Original 8470-5  
Copies: \_\_\_\_\_  
IDENT 82914

SECRET

January 24, 1990

MEMORANDUM FOR MR. R. PROTTI

c.c. R. Bilodeau

Outlined below is the recent sequence of events on the Thyssen file, as I understand them:

- Jan. 11 - Peter Meerburg, Elmer MacKay's Chief of Staff, writes to S. Hartt, attaching a copy of a letter of comfort which Mr. MacKay would like to send to the Chairman of Thyssen Industrie AG in West Germany.
- The letter expresses "the Government's strong interest and support for the establishment ...by Thyssen of a major manufacturing facility in Cape Breton". The letter goes on to note that the Government and Thyssen have been engaged in discussions in recent years over such a facility, and more recently over a new proposal by Thyssen subsidiary, Bear Head Industries, to produce environmental protection equipment. The letter states that "should Thyssen wish to pursue such a manufacturing facility, the Government is prepared to lend its support ...and to begin to work immediately to prepare a package of assistance."
- Jan. 19 - R. Bilodeau memo to S. Hartt (attached): reviews background to proposal. Recommends MacKay letter be toned down to express "willingness to discuss" but avoid giving a firm commitment of assistance.
- About this time, Mr. Schreiber of Bear Head arrives in Ottawa, seeking a firm expression of Government support in advance of a Friday, January 26 meeting in Germany of Thyssen's Board of Directors. (PCO was not informed by ACOA of Mr. Schreiber's efforts, nor of the date of the impending Board meeting.) The Board meeting apparently involves an "auction" for new development funds, open to all of the conglomerate's subsidiaries.

Jan. 23 - Mr. MacKay passes a note to P. Tellier expressing fear that the project will go to the U.S. if Schreiber is not given a letter of comfort. Note is passed to R. Bilodeau, who follows up with ACOA/Lesaux and with PMO to try to determine whether there is an inclination at PMO to provide letter of comfort.

- MacKay places a midnight call to P. Tellier.

Jan. 24 - M. Smith speaks to PMO/Grauer. According to Grauer, Hartt is firm that no letter be sent to Thyssen, on grounds that any letter would sound like a plea and would put the Government of Canada in a weak negotiating position in any subsequent discussions with Thyssen. After speaking to Meerburg (about 4 pm), Grauer also reports that Tellier apparently had convinced MacKay that letter should not go forward. Grauer's view is that a decision had effectively been made not to send a letter to Thyssen.



Maureen Smith

Attachment

PS: Bob Brauer called back at 7:55 to say that MacKay had gone back to the charge with S. Hartt, only this time to argue for a letter of support for a Bear Head military project, based on a Sept. 8 understanding with Bear Head. Hartt appears is now inclined to authorize a letter of comfort, as long as it is completely non-committal as to federal support.



T. Trbovich  
S. Brown  
Dewar  
K. Wright  
A.M. Doyle  
R. Bilodeau  
J. Billings  
Circ  
Chron  
Subject  
PCO Files

SECRET

January 19, 1990

MEMORANDUM FOR STANLEY HARTT

c.c. Paul M. Tellier  
Ray Protti

PCO - FPRO BCP - BRFP
Original: 8470-5
Copies: _____
Ident: 21408 <i>Wm</i>

Thyssen Project

We understand that Minister MacKay is seeking your guidance on dealing with Thyssen AG with respect to their project to build a manufacturing plant at Bear Head, Cape Breton Island. The purpose of this note, which was requested by your office, is to recap some of the key events and issues surrounding this file.

History of the Project

- o The project has its origins in efforts by then Minister Sinclair Stevens to find economic projects and foreign investment to address Cape Breton's persistent unemployment.
- o Thyssen AG has long been interested in establishing a manufacturing plant in North America to compete for Canadian and U.S. procurement of military vehicles. Cape Breton offers advantages to the company, including potential assistance from the provincial and federal governments.
- o The original project received a good deal of unfavourable media attention in 1985 and 1986, essentially charging that Thyssen intended to export military vehicles to sensitive areas such as the Middle East and would use the Cape Breton plant to circumvent West German export controls.

- o The Government has repeatedly stated since then that any exports from the plant would be subject to stringent export controls. The project was still attractive to Thyssen because there was a prospect of significant U.S. and Canadian orders for military vehicles.
- o Discussions within the federal government and with the company through 1987 and 1988 centred on Thyssen's request for a directed contract for 250 light armoured vehicles (LAV) and on the level and source of financial assistance. Thyssen also reached an understanding with Lavalin that would see some sub-contracting flow to the former Hawker-Siddeley plant in Pictou County.
- o On September 27, 1988 an Understanding-in-principle was reached with the company and ratified by Cabinet (5-0361-88RD(01)). The next day an announcement was made (with Mr. MacKay participating) that the plant would go ahead. The agreement was carefully drafted to provide comfort to the company but to minimize legal commitments by the federal government.
- o The original project called for an \$85 million investment, \$58 million from the company, which applied for the Cape Breton Investment Tax Credit on its share. Nova Scotia was to provide the site. The federal assistance package included \$27 million plus the cost of tax credits and other assistance for which the project might qualify.
- o The September, 1988 agreement requires a number of issues to be resolved before any final agreement, including the level and form of any federal assistance, the possibility of armoured vehicle contracts, and submission of a business plan acceptable to the government that would provide for a diversified range of products. These issues have not been resolved to date.
- o Since 1988, federal expenditure cuts have altered DND planning and there is no prospect of LAV orders for the foreseeable future. The ability of the plant to produce and find markets for a range of non-military products is critical to its success. Any estimate of the potential number of jobs should be treated with extreme caution in the absence of a business plan.

- o With ACOA assistance, Thyssen's Canadian company, Bear Head Industries, has retained Price Waterhouse to look into the market for non-military products. The company apparently has some prospects to sell emission control scrubbers for thermal power plants. This is presumably the "environmental field" referred to in the draft letter from Mr. MacKay to the company. Preliminary results of the Price Waterhouse study may be available informally in February.

Issues to be resolved

- o Despite Government disclaimers, there are still concerns that the plant may be ultimately intended for military exports to sensitive areas. The Prime Minister received a letter voicing such concerns in September, 1989 from Sidney Spivak on behalf of the Canada-Israel Committee. This aspect would require very careful handling if the project goes ahead.
- o The federal government has tried to keep the onus on Thyssen to develop a business plan and demonstrate the viability of the plant. It would be counter-productive for the Government to appear too eager or to provide too strong a level of comfort to the company before that work is done.
- o The level and form of any federal assistance would still have to be resolved, as the project is too large for ACOA to handle and DIST has no reserves for large projects.
- o Thyssen AG is a decentralized conglomerate, in which operating subsidiaries compete for available investment capital in a sort of auction process. It is not clear that the parent company will still give the Cape Breton project a high priority if the rationale shifts to non-military products. Thyssen is still in the running for U.S. military vehicle procurement, but it is not clear whether they would use a Cape Breton plant if they win the contract.

Comment

With the LAV procurement cancelled and such key issues unresolved, it is not clear the Board of Directors of the German parent company is still supportive of any project in Canada. While Mr. MacKay's desire to provide Thyssen AG with some reconfirmation of the Government's interest is understandable, you may wish to suggest toning down his proposed letter. The letter should indicate a willingness to discuss development opportunities in a general way but avoid giving too firm a commitment until Ministers are in a position to examine a specific proposal and to decide whether the initiative is still viable, preferably once preliminary results of the Price Waterhouse study are available.

  
Ronald Bilodeau

Wernick/da



10 ←  
class in  
Thyssen  
5-1  
25/1/90

U.S. 115  
(1331)  
SECRET

January 25, 1990

Jan 25 1 10 PM '90

MEMORANDUM FOR MR. P.M. TELLIER

GROUP 00  
CLASSIFIED

PCO - FPRO - BCP - BR
Original: 8470-5
Copies:
Ident: 21279 01A

has ←  
note  
Thyssen  
CT

Letter to Thyssen

We understand that Mr. MacKay and Mr. McKnight, with the agreement of PMO, agreed last night that Mr. McKnight would send an anodyne letter of comfort to Thyssen Industrie AG. The letter (draft attached) would note the Government's long-term intent to acquire a fleet of military trucks, and offers Thyssen the opportunity to participate in tendering on the contract, subject to its ability to meet technical specifications.

After consulting with Ward Elcock, we have provided comments back to PMO, with the intent of ensuring that no legal obligation on the part of the Government is engendered by this letter to Thyssen.

R.  
Ronald Bilodeau

Smith/de

Attachment



To  
Pour: Bob Grauer

Date  
Jan. 25/90

Subject:  
Objet: Bear Head Industries

From: Ronald Bilodeau  
De:

Via:

Your Signature  
Votre Signature  
 For Comments  
Observations

Information  
 Material for the P.M.  
Documents pour le P.M.

Remarks:  
Remarques:

I talked to Ward Elcock on the Thyssen letter. A few minor suggestions in paragraphs 2 and 3. Para. 4 should probably be deleted since we are not really undertaking anything beyond our regular government practice. A time limitation is therefore not very relevant.

c.c.

Drafting officer  
Rédacteur

DRAFT

KARL - HEINZ SCHREIBER  
BEAR HEAD INDUSTRIES LTD.

On September 27, 1988, an Understanding in Principle was signed between Bear Head Industries Limited and the Government of Canada (represented by the Minister of National Defence, the Minister of Industry, Science and Technology and the Minister responsible for the Atlantic Canada Opportunities Agency) expressing the intent of the parties that Bear Head Industries establish a manufacturing facility on Cape Breton Island in the province of Nova Scotia.

In order to provide a basis for discussions leading to the formalization of plans to proceed with the realization of this project, I am pleased to confirm that, in the event that the Canadian Forces determine to acquire a Multi-Role Combat Vehicle, and subject to Bear Head Industries Limited satisfying in all respects the specifications and design requirements of the call for tenders and all contractual matters, Bear Head Industries Limited will be given an opportunity to ~~participate~~ *participate in the tendering* for the contract to supply such vehicles.

TO CON  
THAT A  
WILL BE  
COMPETIT.  
NOT  
SOLE  
SOUR

It must be understood <sup>however</sup> that the Canadian Forces are still in the process of developing their plans for future acquisition of material and equipment, that, in particular, no decision has yet been reached or approved by the Government, to proceed with such an acquisition, and that such decision will remain in the sole discretion of the Government. Nevertheless, current evaluation of possible requirements for armoured vehicles indicates that variants on the TH-495 design currently available from the parent company of Bear Head Industries Limited could satisfy the characteristics and capabilities, as presently defined, of the type of armoured vehicle being contemplated.

reverse  
order  
of  
sentences  
as noted.

delete  
if pos.

THIS undertaking will remain valid for a period of five years from the date hereof, and may only be renewed by express stipulation in writing.



If the foregoing is acceptable as a basis for the commencement of discussions leading to the building of the subject facility in the province of Nova Scotia, we would be prepared to participate in more detailed discussions at your convenience.

Yours truly,

William McKnight  
Minister of National Defence



Minister of National Defence



Ministre de la Défense nationale

January 25, 1990

Mr. Karlheinz Schreiber  
Chairman, Bear Head Industries Ltd.  
Suite 906, 350 Sparks Street  
OTTAWA, Ontario  
K1R 7S8

Dear Mr. Schreiber:

On September 27th, 1988, an Understanding in Principle was signed between the Government of Canada (represented by the Minister of National Defence, the Minister of Industry, Science & technology, and the Minister responsible for the Atlantic Canada Opportunities Agency) expressing the intent of the parties that Bear Head Industries establish a manufacturing facility on Cape Breton Island in the province of Nova Scotia.

In order to provide a basis for discussions leading to the formalization of plans to proceed with the realization of this project, I am pleased to confirm that, in the event that the Canadian Forces determine to acquire a Multi-Role Combat Vehicle, and subject to Bear Head Industries Limited satisfying in all respects the specifications and design requirements of the call for tenders and all contractual matters, Bear Head Industries Limited will be given an opportunity to participate in the tendering for the contract to supply such vehicles.

Current evaluation of possible requirements for armoured vehicles indicates that variants on the TH-495 design currently available from the parent company of Bear Head Industries Limited might satisfy the characteristics and capabilities, as presently defined, of the type of armoured vehicle being contemplated. It must be understood, however, that the Canadian Forces are still in the process of developing their plans for future acquisition of material and equipment, that, in particular, no decision has yet been reached or approved by the Government, to proceed with such an acquisition, and that such decision will remain in the sole discretion of the Government.

This undertaking will remain valid for a period of five years from the date hereof, and may only be renewed by express stipulation in writing.

If the foregoing is acceptable as a basis for the commencement of discussions leading to the building of the subject facilities in the province of Nova Scotia, we would be prepared to participate in more detailed discussions at your convenience.

Yours sincerely,

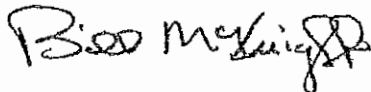

Bill McKnight





278

## BEAR HEAD INDUSTRIES LIMITED

Suite 900, 350 Sparks Street  
Ottawa, Ont., Canada  
K1R7S8

TELEPHONE (613) 563-3321

TELEFAX (613) 563-7648

13 February 1990

Mr. Robert Fowler  
Deputy Minister  
Department of National Defence  
101 Colonel By Drive  
Ottawa, Ontario  
K1A 0K2

Dear Mr. Fowler:

Thank you for providing the opportunity to meet on February 5, 1990, and to have such open and frank discussions with you and your colleagues in the Department of National Defence (DND), and the other departments of the Government in attendance.

As you said at the opening, this was a meeting which was long overdue. I hope that it provided a clearer understanding of the capabilities of the THYSSEN GROUP of companies as they relate to the interests of Canada and DND.

Certainly, from our perspective at Thyssen, we found your statements and those of your colleagues to have been enlightening.

I am sure you are aware of the importance of this meeting to THYSSEN, and the fact that its outcome will be the basis of decisions we will make with respect to whether we proceed or abandon our investment plans as they are proposed for Nova Scotia.

With this in mind, I would like to share with you the understanding we have taken from the meeting and ask that you correct me in any area where I am not accurate.



BEAR HEAD INDUSTRIES LIMITED

It was our obvious interest to learn of requirements in the field on armoured vehicles so I will first review the principal points in that area:

- The undertakings of the Government which have so far been offered to the company in the form of the September 27, 1988 "Understanding in Principle" which carried the signatures of Hon. Perrin Beatty, then Minister for DND and his ministerial colleagues for ACOA and DRIE, and more recently Minister McKnight's letter of January 25, 1990 were in your opinion, the maximum that could be offered to the company;
- Geo-political events are having impacts on the DND budget;
- A new budget is due soon (now announced for Feb. 20th), and there is speculation that DND will be affected by further cuts to capital spending;
- It is not yet possible to commit to an Army need within your DND planning framework which is now under review;
- The Canadian Army has a need to replace its current fleet of armoured vehicles with a vehicle described as a Multi Role Combat Vehicle (MRCV);

This MRCV vehicle requirement was described as:

- A basic vehicle capable of serving Canada's Land Forces through their entire range of roles;
  - A family concept using a common chassis to all variants;
  - Eventually replacing the current fleet of armoured vehicles;
  - Some of the vehicles within the current fleet are overdue for replacement;
- While the need for the MRCV was described by the Army, it was pointed out that this need is not automatically a "requirement" of DND until the conclusion of the formal planning process for DND;
- An estimate of timing for conclusion of DND planning is difficult, particularly before the next budget;



## BEAR HEAD INDUSTRIES LIMITED

3

- DND planning is within a 5 year framework for near term and reaches out to 15 years in the long term, and even decisions within the near-term framework are subject to change.

- Estimates of quantity are not possible, but at any rate they were described as small - maybe "hundreds".

- The DND procurement policy and procedural framework was described in considerable detail, with inclusion of these principles which were described as having recently been re-affirmed by the Government:

- i) governed by Treasury Board Rules
- ii) consideration of long term regional development
- iii) meeting National objectives
- iv) assisting Canadian firms to be competitive:

Subsequent to a presentation by Juergen Massmann of a new Thyssen concept vehicle (the TH 495), we turned to some discussions about the Army's current view of the MRCV requirement. There was an acknowledgement that the TH 495 vehicle concept presented appears capable of meeting the MRCV requirement as it is defined at present in Army planning

Comments that were made by the other Government departments in attendance are summarized as follows:

The ISTC (DRIE) departmental objective, since some five years, was to find a proposal with the maximum possibility of success. Furthermore, it was noted that consideration for regional industrial development falls within the procurement process described by Mr. Healey, and it is within that process that ISTC continue to work to serve the objectives of industrial development. Lastly, ISTC cited the 1992 statutory deadlines of the Cape Breton Investment Tax Credit Program for which there is an application from Thyssen/Bear Head Industries.

ACOA also acknowledged their support for the procurement policy outlined by Mr. Healey, and made specific reference to ACOA's intention to continue to encourage the regional industrial benefits considerations within the procurement process. ACOA also pointed out the positive economic impact to the Atlantic Region through realization of the Thyssen/ BHI investment, and that it is somewhat unique as an industrial investment opportunity for this particular region of Canada.





BEAR HEAD INDUSTRIES LIMITED

4

Thyssen responded to the DND suggestions that an MRCV designed specifically for Canada would be expected to be very expensive and that the numbers contemplated in the MRCV requirement are "very small relative to programs of other Armies".

The essential point of our response was to explain the TH 495 concept is based upon major components and systems which are state of the art developments, all of which are proven and operating as existing systems. This utilization of proven systems allows Thyssen to offer the TH 495 concept without having to carry prohibitive costs for the development of each individual system and it allows reduced logistics and operating costs for the user.

On the point of DND's concern that Canadian quantities needed may be regarded as "too small", Thyssen/BHI explained that our experience in vehicle programs has proven that even a program of a few hundred units is very significant to Thyssen, and that we have based our TH 495 concept on meeting programs of that size, cost effectively.

Mr. Fowler, I invite you to correct any inaccuracy in this summary of our discussion and I hope that I will have the opportunity to meet with you again before my return to Germany.

Sincerely,  
BEAR HEAD INDUSTRIES LTD.

  
Karlheinz Schreiber  
Chairman

cc. Hon. Elmer MacKay, P.C., M.P.  
Minister for Atlantic Canada Opportunities Agency





## BEAR HEAD INDUSTRIES LIMITED

Suite 908, 350 Sparks Street  
Ottawa, Ont., Canada  
K1R7S8

TELEPHONE (613) 563-3321

TELEFAX (613) 563-7648

March 5, 1990

PRIVATE AND COMMERCIAL CONFIDENTIAL  
HIS EYES ONLY!

The Hon. Elmer MacKay  
Minister of Public Works  
Room 509  
Confederation Building  
House of Commons  
Ottawa, Ontario  
K1A 0A6

Dear Elmer:

At the end of November 1989, I wrote to you expressing my frustration around the Thyssen Industrie AG (Thyssen) plan to establish in Nova Scotia. At that time I shared with you my fear that the chance to make this project a reality was being lost. In a subsequent meeting with you I promised to make every effort from the Thyssen side to ensure that we not abandon our plans to invest in Canada until seeing the outcome of one last and final effort to make the Thyssen investment possible.

I attach for your reference my letter to you of November 29, 1989 which summarizes the events up to that date.

Today I am writing to provide you with a summary of the recent events that have taken place around the project.

1. I received from Minister Bill McKnight a letter dated January 25, 1988. This letter acknowledged the capability of Thyssen/Bear Head Industries to meet the army's potential requirements for the Multi Role Combat Vehicle (MRCV). However, Mr. McKnight's letter did nothing to expedite the placing of a start-up order, but rather hedged against any undertaking that would get our project off the ground in the immediate future.
2. However, through your and Mr. McKnight's good offices, a meeting was set up for February 5 at the Department of National



## BEAR HEAD INDUSTRIES LIMITED

Defence Headquarters, where senior defence officials and representatives of the Departments of Finance, Supply and Services, Industrie, Science & Technology (ISTC/DRIE), and External Affairs and Atlantic Canada Opportunities Agency were in attendance.

3. Prior to that meeting being held, I met with Mr. Stanley Hartt, Chief of Staff, PMO, where we outlined our plans for Eastern Canada and discussed why the initial start-up order from National Defence was required. Mr. Hartt seemed to understand what the position was and volunteered that what was required was a senior government person to act as a catalyst between Bear Head Industries and National Defence and he was to advise us of his choice. I concurred with this suggestion; but to date, have not heard from Mr. Hartt as to his nominee even though our meeting was held over a month ago.

4. On February 5, a meeting was held in the offices of the Department of National Defence attended by those mentioned in item 1 above. The meeting outlined a possible requirement by the army for the MRCV; however, at that time, they could not give us an official confirmation. It seemed that the meeting was very carefully scripted and the words used by DND officials were very carefully chosen. Our interpretation of the meeting was written in a letter to Mr. Robert Fowler, Deputy Minister of Defence, on February 13, a copy of which is attached. We, as we have come to expect, have heard nothing further from Mr. Fowler.

5. On February 8, I joined a meeting with L-Gen. David Huddleston. I had agreed to this meeting for the separate purpose of follow-up discussions on the outcome of the Atlantic Bridge Conference hosted in Germany in November, 1989 - where I was a delegate and met General Huddleston. Arriving at General Huddleston's office, I found M-Gen. Reay who had presented the army's MRCV requirement in the February 5 meeting at DND. At this point, I learned that L-Gen. Huddleston wanted to return to additional discussions on the topics of February 5. In summary, L-Gen. Huddleston's message seemed intended to:

a) discourage Thyssen from continuing to pursue the MRCV project at this time because in his view this army requirement was far from being accepted with any priority within overall DND requirements.

b) to warn Thyssen that continuing to pursue the MRCV project would risk damage to the relationship of Thyssen within DND - whereby, in effect, if Thyssen pursued their interest in the project in Nova Scotia, they would end up with "nothing at all."



## BEAR HEAD INDUSTRIES LIMITED

All in all, a very unsatisfactory discussion at what was supposed to be an unrelated meeting.

6. On February 14, a meeting was held with John Crosbie, Minister of International Trade, where once again, I outlined together with yourself the concept of Bear Head Industries' potential investment in Eastern Canada. Mr. Crosbie expressed a great deal of interest and was particularly keen on the export potential of the company. Minister Crosbie acknowledged particular interest in the export potential of the Thyssen range of technologies which can be produced from Bear Head as well as support for the positive economic impact that the Bear Head Industries plant would bring to Atlantic Canada. The meeting was very satisfactory and concluded with Mr. Crosbie offering any help he could.

7. Since the above meetings, we now understand that the Canadian Army has confirmed the need for an MRCV and have designated it as the Army's top equipment priority. Although the Development Plan for the Canadian Forces as a whole has not yet been finally decided, a core requirement of the revised force structure for the land element is expected to be the MRCV.

At this point, I would like to repeat once again, that the reason for the start-up order of 250 vehicles is required by us, is so that we can have one year of stable production at a time when we are lining up various environmental and industrial projects.

In that regard, since I have corresponded with you last, we have been advised by the Government of Argentina that Thyssen have pre-qualified on the Corredor Rosario-Bahia Blanca project. This project involves the restructuring, building and operation of a railway in that country. If successful, it could mean up to 5,000 km. of railway track to be purchased, engineering for the project and the supply of locomotives, cars, etc., with the technology being supplied by Thyssen-Germany with significant production mandated to Bear Head Industries and also to other Canadian subcontractors, where possible. Arrangements have been made for payments in hard currency.

Additionally, I have met with the principals in Las Vegas on a high speed rail link between Los Angeles and Las Vegas where the Thyssen Transrapid Magnetic Levitation Train is a front runner (press clippings attached). This multi-billion dollar project would have a substantial spinoff for Bear Head Industries.

I have also had meetings in Alberta and with American businessmen regarding environmental equipment requirements. It is now obvious tens of billions of dollars will be spent on



## BEAR HEAD INDUSTRIES LIMITED

environmental protection in the next few years and as you know, Thyssen has given the mandate to Bear Head Industries to produce the entire range of environmental equipment for North America. Already, Thyssen has provided 17 coal-fired power units in the U.S. with scrubbers - whose value is in excess of \$1 billion U.S. We were also advised in Alberta that they have an industrial commitment of \$30 billion in new investment (only projects over \$50 million included) primarily in the oil and gas and pulp and paper industries. Each of these sectors requires critical environmental protection technologies which we hope to offer from our Nova Scotia plant in cooperation with Western Canadian contractors.

As we have discussed many times before, a great many industrial initiatives were possible from the proposed Bear Head Industries base. However, it is virtually impossible to do so without an initial start-up order. We have not asked the Canadian government for huge grants, soft loans or any other meaningful financial contribution to our factory, but rather for a start-up order in order to secure Thyssen's establishment in Canada instead of the United States, as our North American base for the entire range of Thyssen heavy industry technologies.

I will be returning to Germany on Friday, March 9, to report to the Thyssen Board. Anything you can advise me before I leave would be appreciated. In the meantime, I would like to thank you sincerely for your dedicated effort and understanding of what we are trying to do. I remain,

Yours sincerely,



K. Schreiber  
Chairman

KHS/no'n





## BEAR HEAD INDUSTRIES LIMITED

Suite 908, 350 Sparks Street  
Ottawa, Ont., Canada  
K1R 7S8

TELEPHONE (613) 563-3321

TELEFAX (613) 563-7648  
TELEX 053-3981 bhi ott

Hon. Elmer MacKay  
Minister of Atlantic Canada Opportunities Agency  
509 Confederation Building  
House of Commons  
Ottawa, Ontario  
K1A 0A6

13 March 1990

Dear Minister,

Further to our excellent meetings with the Minister of National Defence, the Minister of International Trade, and our discussions with the department of National Defence, I have returned to Germany and received authority from the board of Thyssen Industrie (THYSSEN) to agree on behalf of the company, to the concession outlined in my most recent meeting with you.

I ask that you share this with your colleagues, and should you require any further elaboration, please contact me at my office in Germany, where I will be available at your convenience.

It is my belief that this concession from the Thyssen side represents a significant offer which should allow both sides to reach agreement and allow us to proceed immediately to the construction of the plant, hiring and training of workers and manufacturing and delivery of product.

An early response to this proposal would be appreciated as the situation within THYSSEN has reached a final stage where we intend either to proceed with the BHI proposal as our North American base, or let alternative plans go ahead for expansion in these same fields with plant facilities based in the United States.

Sincerely,

  
R. Schreiber  
Chairman

sinc





Minister of National Defence

Ministre de la Défense nationale

22 MAR 1990

② .CS

Mr. Stanley H. Hartt  
Chief of Staff  
to the Prime Minister  
Prime Minister's Office  
Langevin Block  
80 Wellington Street  
Ottawa, Ontario  
K1A 0A2

TRANSIT RECORD

File Reference

Processed by	Initials	Date

*Info:*  
*[Signature]*

Dear Mr. Hartt,

As agreed to at our meeting of February 1, 1990, my Deputy Minister, Bob Fowler, convened a meeting of government officials and representatives from Thyssen and Bear Head Industries on February 5 to discuss Thyssen's proposal to build a manufacturing plant in Cape Breton. The group of officials included representatives of every relevant government department with an interest in the Thyssen/Bear Head issue. Also present were several senior army officers including General John de Chastelain, Chief of the Defence Staff.

There was a general feeling on both sides that, for the past few years, the Thyssen file had been characterized by misunderstanding and misinformation. Consequently, both sides expressed a clear desire for openness which contributed to a full and frank exchange of views during the meeting. You will clearly detect this candid spirit running through the enclosed summary record of discussion.

Mr. Fowler, supported by officials from other departments, made a number of points relating, on one hand, to the way the Government does business and, on the other hand, to the nature of the Canadian Forces' requirement for military vehicles.

*3*  
*[Handwritten notes]*  
.../2

STANLEY H. HARTT

With regard to the former, my Deputy Minister made it clear to Thyssen/Bear Head officials that the federal government's procurement policy is founded on the principle of competitiveness driving efficient procurement. He stressed that the current trend toward declining defence budgets reinforced the need for my Department to maximize painstakingly, the military utility of each defence procurement expenditure. As a footnote, Mr. Fowler advised company representatives that it was regrettable and intolerable that this need for a disciplined departmental process to scrutinize future defence equipment requirements had been misconstrued in some circles as self-serving, military tribalism. He stressed that such allegations questioning the integrity of senior DND officials and military officers were unfounded, unproductive and unacceptable.

With regard to the need for military vehicles, you will note from the enclosed record of discussion that the company was given an overview of the Canadian Forces' future requirements. Officials stressed that the army, whatever its future structure and role, would need a range of armoured vehicles but that there are no plans to acquire any soon. Specifically, no decisions on future armoured vehicle procurement could be anticipated with the next three to four years and no production envisaged within the next five to six years. Further, government officials stressed that any potential Canadian military vehicle requirement - armoured or otherwise - would be small by international standards.

Mr. Fowler emphasized that the Canadian Government would welcome Thyssen investment in Canada. Officials acknowledged Thyssen's strong reputation as producer of an extensive range of excellent, albeit expensive, equipment product lines. At the same time, the group reminded company representatives that international competition among such equipment suppliers would become far more fierce in the future. Further, Thyssen representatives were told that officials believed that no Government would issue a carte blanche on export permits. Officials concluded that the Government would no doubt welcome a decision by Thyssen to set up a manufacturing plant in Canada on the basis of a full understanding of these realities.

.../3

Finally, I would like to clarify the issue of the General Motors Light Armoured Vehicle (LAV) performance with United States' troops in Panama. You will recall that at our February 1 meeting, Elmer Mackay suggested that Bear Head Industries representatives had indicated to you that the GM LAV had performed poorly in Panama. As we agreed, my officials sought clarification from the US Department of Defence, specifically during my Deputy Minister's visit to Washington on February 23. I am enclosing a report on the LAV's "sterling performance" in Panama which has been received from US Deputy Secretary of Defence, Don Atwood. This report refutes any accusation that the Americans were not pleased with the performance of the GM built LAV during their recent operations in Panama.

I had the opportunity to meet for 45 minutes with Mr. Schreiber and the Honourable Elmer MacKay in the lobby of the House of Commons on March 9. During our discussion, I repeated and re-emphasized the points which were brought out at his meeting with our officials on February 5.

Yours sincerely,

Original Signed by  
HON BILL McKNIGHT  
a signed original

Bill McKnight

Enclosures: 2





# BEAR HEAD INDUSTRIES

Suite 908, 350 Sparks Street  
Ottawa, Ont., Canada  
K1R7S8

TELEPHONE (613) 563-3321

TELEFAX (613) 563-7648

April 5, 1990

Confidential

Hon. Elmer MacKay  
Minister of Atlantic Canada  
Opportunities Agency  
  
509 Confederation Building  
  
Ottawa, Ontario  
K1A 0A 6

Dear Minister,

this letter follows our conversation of yesterday, during which you informed me that certain officials in the Government of Canada had raised certain questions to which you have requested a response, namely:

1. the capacity of our machine to be airlifted;
2. the integrity of the U.S. order, and our response to the claim that this order had been cancelled;
3. the matter of whether the Canadian forces seek a wheeled or a tracked vehicle.

For the last five years, Minister, our approach has been forthright at all times. You will appreciate that I am somewhat disturbed that our integrity may have been questioned, and I am further upset that misinformation continues to circulate as regards this project.

34120258 -



## BEAR HEAD INDUSTRIES LIMITED

However, I welcome the opportunity once again to address these matter in the hope that we can continue to make progress on this project at a time when progress is critical, dictated by the urgency of addressing the US order. I have always fought for the Canadian venue, and will continue to do so until time limits my options.

I am including a letter from our parent company which addresses the matters you have raised; I also include a copy of Jane's Defence Weekly of March 24, 1990. These documents address the issue you have raised.

1. The TH 495 <sup>No NAME</sup> vehicle family, in all its configurations including the highest ballistic protection, is air transportable. Any statement to the contrary is wrong. Furthermore, the FOX vehicle will also be air transportable as appears in the attached letter.
2. Thyssen has received an order for FOX vehicles from the US; we have no reason to believe that this order shall be limited to 48 vehicles. Indeed, all our planning is now for the production of 210 vehicles. The suggestion that the US order has been cancelled by the US is both wrong and mischievous.
3. As you know, Thyssen is capable of producing both wheeled and tracked vehicles. If we have concentrated on the tracked vehicle in our discussions with you it is because of our understanding that tracked vehicles are the option of preference for the Canadian forces. We have been actively involved in ongoing meetings with the Canadian army and this continues to be our belief. Anyone suggesting the contrary should check with senior army officers involved with this project. But should that preference change we are prepared and capable to produce wheeled vehicles. As a matter of fact, both our wheeled and our tracked vehicles are, we firmly believe, superior to anything else in the world today.

3 BT 1601.005

34120259 -



## BEAR HEAD INDUSTRIES LIMITED

---

Finally, I have ascertained that should further confirmation be required on any of these points, the West German Deputy Minister of Defence, Mr. Dr. Holger Pfahls, Staatssekretär des Bundesministeriums der Verteidigung, 5300 Bonn 1, Harthöhe, Tel. Nr. 0228 - 129120, has agreed to meet with any of your officials, in Canada if need be, to clear up any other questions.

Minister. I trust this addresses the matters you raised with me, and permits us all to proceed to make this project a reality.

Thank you for your continued interest.

Sincerely,

Bear Head Industries Ltd.

Karlheinz Schreiber  
Chairman

09.08.74  
FW-9392

OTT A 105

34120260-







**Bombardier Inc.**  
**Corporate Office**  
 17th Floor, 800 René-Lévesque Blvd. West  
 Montréal, Québec H3B 1Y8  
 Telephone (514) 861-9481  
 Telex 055-62129 - Facsimile (514) 861-7053

001350062

May 11, 1990

PCO - FPRO	SCP - DREF
Original:	84 70-20
Copies:	
Ident:	52 029 Jan.

The Right Honourable Brian Mulroney  
 Prime Minister  
 Government of Canada  
 Prime Minister's Office  
 Langevin Block  
 80 Wellington Street  
 Ottawa, Ontario  
 K1A 0A2

Dear Prime Minister:

I am writing to you directly to seek your help in resolving a problem that has recently arisen.

At Canadair, we have developed and manufactured a surveillance drone, the CL-289. A German company, Dornier, a subsidiary of Daimler-Benz and a French company, Société Anonyme de Télécommunications, are our partners in the project. The drone is a sophisticated high technology product that is entirely dependent on export markets.

In 1988, Canadair won a \$400M order from Germany and we now have the prospect of a follow-on order of \$175M. Given our order book for this product, the employment prospects of more than 200 Canadair people and other Canadian suppliers depend on this follow-on order from Germany.

It has recently come to our attention that a Mr. Karlheinz Schreiber, of Bear Head industries (Thyssen) in Cape Breton, has been encouraging German government officials and Ministers to not approve the CL-289 follow-on order unless a Light Armoured Vehicle project, directed by Thyssen, is approved by the Canadian Government. We have also been told that the Honourable Elmer McKay has been supporting Mr. Schreiber in these efforts.

While we have no direct knowledge, we understand that the chances of the Bear Head project going forward are small. If this is the case, we need to find a way to delicately unwind an increasingly difficult situation for the CL-289 German project.

...2/

We have heard that a budgetary decision on the CL-289 will be taken on May 19 in Germany and that is why we feel that the matter is urgent. If you decide not to go forward with the Bear Head project, and we continue in the present manner, the risks are high that we will lose everything from a Canadian point of view.

I am sorry to have to bother you with this issue but I believe that your personal intervention is needed to help get our project back on track.

Your sincerely,

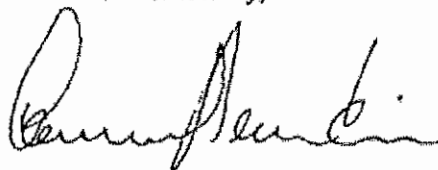

Laurent Beaudoin  
Chairman and  
Chief Executive Officer





## BEAR HEAD INDUSTRIES LIMITED

Suite 908, 350 Sparks Street  
Ottawa, Ont., Canada  
K1R7S8

TELEPHONE(613)563-3321

TELEFAX (613) 563-7648

July 6, 1990

Mr. Paul Tellier  
Clerk  
Privy Council  
Langevin Block  
Ottawa, Ontario  
K1A 0A2

Dear Paul:

Thank you for taking the time to meet with me and the Hon. Elmer MacKay on the Bear Head project.

I am very encouraged by the Prime Minister's support in this project.

After five years' experience, I am firmly of the opinion that this project is good for the entire country and most especially Atlantic Canada.

Our experience also teaches us, however, that there are pockets of misinformation, either arising out of honest error or otherwise.

Much of the last five years has been spent identifying and subsequently debunking this misinformation.

I mention this so that should you hear of any alleged negative aspects of the project, I urge you to contact me immediately so that I may give you the necessary information.

.../2



BEAR HEAD INDUSTRIES LIMITED

---

- 2 -

I am totally confident that a simple phone call to myself or Mr. MacKay, who is well aware of this file, will set the record straight should you ever encounter any such misinformation.

Thank you again.

Sincerely,

Karlheinz Schreiber





## BEAR HEAD INDUSTRIES LIMITED

Suite 908, 350 Sparks Street  
Ottawa, Ont., Canada  
K1R7S8

TELEPHONE(613)563-3321

TELEFAX (613) 563-7648

July 6, 1990

Mr. Robert Fowler  
Deputy Minister  
Department of National Defence  
101 Colonel By Drive  
Ottawa, Ontario  
K1A 0K2

Dear Mr. Fowler:

While I appreciate the fact that you have many matters requiring your attention, I have yet to receive a reply to my letter of February 13, 1990.

Thyssen's interest in, commitment to, and investment in the Bear Head project was at the invitation of the Canadian government and I find it difficult to accept that we are denied the most basic of courtesies.

Yours truly,

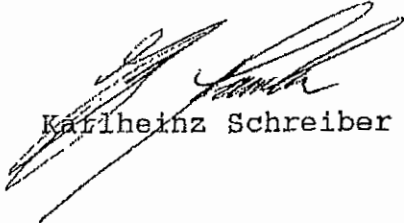

Karlheinz Schreiber

cc: The Hon. Elmer Mackay







PCO - PPRO	BEP - BPP
File No.	8470-5
Date	
Ident.	29242

SECRET

July 12, 1990

*F.M.*

*A - add*  
*1. Tel. conf. discussion*  
*2. s.o.j. dis. center*  
*Fowler.*

MEMORANDUM TO THE PRIME MINISTER

Thyssen/Bear Head Industries

BACKGROUND

*3. The*  
*media*  
*but*  
*the*  
*concern*  
*Bear*

As you had requested, I met recently with Elmer MacKay and Karlheinz Schreiber, Chairman of Bear Head Industries Ltd., to discuss the Thyssen initiative. Mr. Schreiber described the history of this initiative which started in 1985 as a result of the request made by Sinclair Stevens, to West German business people to consider investing in Canada. Following this request, discussions started with Thyssen about the possible construction of an industrial facility in Cape Breton to assemble armoured vehicles, other metal products and environmental protection equipment. This led Thyssen to set up Bear Head Industries to pursue the initiative and to conduct the discussions.

*4. Note*  
*on*  
*PM*  
*sent*  
*O.I.*

In July of 1988, the Ministers of Regional Industrial Expansion, National Defence and the Minister in charge of ACOA signed an Understanding in Principle with Bear Head Industries which outlined the areas on which discussions had been held up to that time and understandings reached. For its part, Thyssen undertook, if it received an order for 250 Armoured Personnel Carriers, to proceed with the construction of the Bear Head Plant in Cape Breton.

*10/1/90*

As the discussions have been going on for almost 6 years, Mr. Schreiber feels that the Government should now come to a decision so the project can either be pursued or dropped by the company. I agreed that we were fast reaching decision time and, although a number of major and difficult issues are raised by the project, the Government should come to a decision sooner, rather than later, if it is the case that there is political will to pursue the project. I told my visitors that I would be speaking with you upon your return from the Houston Summit.

OTTAWA  
K1A 0A3

(63)

CONSIDERATIONS

In arriving at a decision about this project you will want to weigh the following factors:

1. Defence Equipment Requirements

Although it recognizes that its current armoured troop carriers are obsolete and are vulnerable to piercing in some limited close range conditions by certain high powered arms, the Department of National Defence is only in the very early phase of assessing its needs for a Multi-Role Carrier Vehicle (MRCV). This means that under the current schedule, a contract for MRCVs could be awarded by 1995-96 assuming no major changes in Defence policy or budgetary circumstances. Taking an earlier decision to procure 250 armoured carriers sole-sourced from Thyssen would therefore mean a major shift in defence procurement priorities that could affect other priorities and contracts in an already very tight Department of National Defence budget.

2. Industrial and Economic Benefits

The commitment made by Thyssen is to invest \$70 million in the short term. The project would create 500 direct jobs, and Bear Head Industries would have access to Thyssen technology. The Understanding in Principle signed in 1988 stated that the Government would also assist the project with its regular programs in force at the time the project proceeds. This means that half or more of the capital costs could be covered by federal grants and tax credits available in Cape Breton.

Additional benefits could result from the fact that Thyssen and General Dynamics have formed a partnership. A North American location could allow Thyssen to have significant access to United States defence procurement. Bear Head Industries could also proceed to a second phase of the project into civilian production.

The benefits are potentially significant but remain only partially quantified at this time. A full business plan would have to be considered in order to assess the long run benefits and the cost to government in terms of direct procurement and subsidies.

A new facility set up in Cape Breton would compete with General Motors in London. You will recall that the Government had awarded General Motors a \$201 million contract for 199 Light Armoured Vehicles in 1989. GM is quite successfully competing in this field having obtained an important contract in Saudi Arabia. Also, a heavily subsidized facility in Cape Breton may raise concern in the U.S. about unfair competition. However we understand from Mr. Schreiber that the U.S. Defence authorities have no concerns about a Canadian location for such a facility.

3. Export Controls

Bear Head Industries' future success would be dependant on exports to the U.S. and to other countries. The possibility has been raised that the West Germans themselves could procure some MRCVs from such a facility. However, not all exports would be to NATO countries and the Government must be prepared to address some difficult export control issues in the event the plant were established in Canada and if orders are received from Middle East countries for example.

COMMENT

An investment of this size, in a depressed region, by a West German company of this stature would be a positive signal about Canada as a place to invest. At a time when Canada is attempting to give a business as usual signal to foreign investors, this would be a reassuring message. However, if the project is less than fully successful, it may simply add to current overcapacity in the sector where GM is operating below its capacity level.

As noted above, pursuing the Thyssen project at this time would require a redirection of the Defence procurement program which would be disruptive and controversial. Exports of Thyssen products from Canada to sensitive countries could potentially be opposed by Mr. Clark on foreign policy grounds. Given these difficult policy issues, the Government's decision should essentially depend on whether the deal is a sufficiently good one from the economic and industrial dimensions and whether it will be worth the cost of assisting it through procurement and subsidies. To make this judgment, a full business plan should be requested from Thyssen, and an analysis of this and the project's costs and benefits would need to be undertaken thoroughly.

39(a)(d) & (e)

I would be pleased to discuss this with you at your convenience.



Paul M. Tellier



CLERK OF THE PRIVY COUNCIL AND  
SECRETARY TO THE CABINET



GREFFIER DU CONSEIL PRIVÉ ET  
SECRETÉAIRE DU CABINET

July 13, 1990

Mr. Karlheinz Schreiber  
Thyssen  
Bear Head Industries Limited  
Suite 908, 350 Sparks Street  
Ottawa, Ontario  
K1R 7S8

Dear Mr. Schreiber,

I was pleased to have the opportunity to meet with the Honourable Elmer MacKay and yourself last week on the Bear Head project.

As you made clear during the meeting, the project has had a long history and hopefully it will be possible for the Government to come to a definitive conclusion about it before too long. Having said that, as I mentioned at the conclusion of the meeting, the project raises major issues in terms of the Government's defence procurement plans, in terms of industrial and regional development policies and in terms of trade policy in a strategic sector. However, an investment of this size in one of Canada's regions of slower economic growth would certainly have positive benefits. The Government will therefore have to weigh all these types of considerations carefully in coming to a conclusion about the project.

It was helpful to hear Bear Head Industries' point of view directly, and this has contributed to our understanding of the benefits of the project from the company's perspective.

Yours sincerely,

A large, stylized handwritten signature in black ink, appearing to read "Tellier".

Paul M. Tellier





Documents in support of the Honourable

Mr. Elmer MacKay

This document is to be inserted behind tab 25a.

64



Atlantic Canada  
Opportunities  
Agency

Agence de  
promotion économique  
du Canada atlantique

President

Head Office  
P.O. Box 6051  
Moncton, N. B.  
Canada E1C 9J8

Siège social  
B.P. 6051  
Moncton (N.-B.)  
Canada E1C 9J8

SECRET

**MEMORANDUM**

**NOV 23 1990**

**TO: The Honourable Elmer MacKay**

**FROM: Peter B. Lesaux**

**SUBJECT: Additions to the Bear Head Industries MOU**

This memorandum attaches wording which you may wish to incorporate into the proposed "Memorandum of Understanding" (MOU) with Bear Head Industries (BHI), to address several sources of potential risk to the Government from entering into an agreement, as constructed, with the Company.

As you appreciate, the credibility of BHI is derived largely from its 100% subsidiary relationship with Thyssen Industrie AG.

Accordingly, it could be potentially damaging to the success of the military vehicle contract, and the subsequent civilian diversification, if Thyssen Industrie AG divested prematurely, or otherwise diluted, its holdings in BHI. (Such a divestiture might arise, for example, if, for tax reasons, Thyssen Industrie sought to transfer its BHI Cape Breton Investment Tax Credit assets to its other Canadian operations.)

While Mr. Schreiber, the Chairman of BHI, is a proposed signatory of the MOU, my understanding is that he has no formal relationship with Thyssen Industrie AG, and thereby may be unable to commit the parent to ownership of BHI.

Should the Government wish to commit Thyssen to maintaining its current ownership of BHI, the Government could require:

*Please in my  
File.  
Bear Head  
W.S.*

**Canada**

1. an officer or authorized board member of Thyssen Industrie AG to sign a strengthened MOU, providing for ongoing ownership of BHI, and/or requiring written consent of ACOA prior to divestiture; or
2. BHI, as a precondition to signing, to provide legal evidence of a firm commitment by Thyssen Industrie AG that it intends to maintain its holdings in BHI, for the duration of its contractual obligations to the Government.

Should you wish to pursue either option, I have attached wording which may be helpful. You will note each text proposes, as an example, that a significant penalty be paid in the event of ownership dilution -- such a penalty should, of course, be discussed in advance with, and understood by, the company. (Our suggestion of a penalty valued at fifty percent of the outstanding tax credit plus the federal share of infrastructure assistance is purely arbitrary.)

In addition, the MOU should indicate that it is an expression of intent, and that a formal contract will be required to specify the terms of agreement. (Wording to support this caveat, which if you agree, could be added to the MOU, is contained in Annex 2.)

Separately, you may wish to enhance the incentives, outlined in the MOU, for BHI to maintain its promised employment levels in Cape Breton. In this regard, you may simply wish to reword slightly existing paragraph 5 a(iii) as outlined below:

5a)iii)

"Should Phase II not proceed, or if the employment level of 400 for Phase I is not sustained for five years, the Company will reimburse the Government of Canada for a portion, to be determined in subsequent negotiations, of the infrastructure assistance provided under paragraph 2(a) above"

From a Government perspective, paragraph 2 b), dealing with the qualification of the tax credit, would appear to bind the Minister of National Revenue. If so, you may wish to seek this Minister's signature as well.

Finally, as you instructed, the MOU has not been circulated within ACOA or interdepartmentally, and has had no legal review. Prior to signature, you may wish to seek a final legal review, in order to ensure the agreement binds each party in the way they would wish. Indeed, you may recall that such a review was directed by Cabinet prior to the signing of the "Understanding in Principle", two years ago.

/att.

  
Peter B. Lessau

SECRET  
ANNEX 1

OPTION 1: SIGNATURE BY A REPRESENTATIVE OF THYSSEN INDUSTRIE AG

In recognition of the very considerable financial, technical, and other capabilities realized by Bear Head Industries as a wholly-owned subsidiary of Thyssen Industrie AG, and the importance of such capabilities to the Government of Canada, Thyssen Industrie AG hereby commits to retain its one hundred percent ownership of Bear Head Industries, for a period of at least five years in duration, commencing from the date of the award of the contract (noted in paragraph 4 b) (i) above) to Bear Head Industries.

Should Thyssen Industrie AG wish to divest, in whole or in part, its holdings of Bear Head Industries, prior to 5 years, Thyssen Industrie AG, will seek written consent from ACOA, and will remit to the Government of Canada a sum equal to fifty percent of the:

- i) aggregate value of the Cape Breton Investment Tax Credit outstanding to Bear Head Industries at the time of sale, and;
- ii) federal contribution to infrastructure (noted in paragraph 2 a) above).

OPTION 2: BHI PROVIDES SEPARATE COMMITMENT BY THYSSEN INDUSTRIE AG

In recognition of the very considerable financial, technical, and other capabilities realized by Bear Head Industries, as a wholly-owned subsidiary of Thyssen Industrie AG, and the importance of such capabilities to the Government of Canada, by copy of the enclosed agreement between Thyssen Industrie AG and Bear Head Industries, Bear Head Industries hereby discloses a commitment by its parent to retain its one hundred percent ownership in Bear Head Industries, for a period of at least five years in duration, commencing from the date of the award of the contract (noted in paragraph 4 b) (i) above) to Bear Head Industries.

Should Thyssen Industrie AG wish to divest, in whole or in part, its holdings of Bear Head Industries, prior to 5 years, Bear Head Industries will seek written consent from ACOA, and will remit to the Government of Canada a sum equal to fifty percent of the aggregate value of the:

- i) Cape Breton Investment Tax Credit outstanding to Bear Head Industries at the time of sale, and;
- ii) federal contribution to infrastructure (noted in paragraph 2 a) above).

SECRET  
ANNEX 2

EXPRESSION OF INTENT

This Memorandum of Understanding is an expression of intent, but it is a condition precedent to the requirement to perform hereunder, that the parties enter into a more detailed contract, more specifically outlining their terms of agreement. The parties agree to proceed forthwith to finalize such contracts.



# Karlheinz Schreiber

Suite 908, 350 Sparks Street, Ottawa, Ontario  
Telephone: (613) 563-3321 Fax: (613) 563-7648

## PERSONAL CONFIDENTIAL FOR HIS EYES ONLY

27 August 1990

The Right Hon. Brian Mulroney, P.C., M.P.  
Prime Minister of Canada  
Ottawa, Ontario  
K1A 0A2

Dear Prime Minister:

First, let me thank you for the telephone conversation last week and I hope that your mother's birthday celebration was a happy event for she and all of your family. As you know, I am going back to Germany this week to celebrate with my mother on the occasion of her seventy-ninth birthday.

In an age as our mothers are, we are fortunate to celebrate every year with them.

Before my departure I wanted to pass on some information which I believe important.

The meeting which I had with Stanley Hartt and Elmer was very interesting and in my opinion it was very productive.

The visit of Winfried Haastert and his colleagues from the Thyssen Industrie AG Supervisory Board was very positive in their understanding of the promising out-look for establishing our new Canadian factory in Nova Scotia.

# Karlheinz Schreiber

Suite 908, 350 Sparks Street, Ottawa, Ontario  
Telephone: (613) 563-3321 Fax: (613) 563-7648

**PERSONAL CONFIDENTIAL  
FOR HIS EYES ONLY**

2

I passed on your regards as you had requested during our telephone conversation and this was both very appreciated and respectfully acknowledged in return.

This group has travelled onward to Los Angeles for project discussions after last week's award to Thyssen for the high speed rail link between Los Angeles and Las Vegas, selecting Thyssen's Magnetic Levitation train which will provide a 500 km/hour connection between the two cities.

Observing Canada has been among the first nations to respond to the Iraqi invasion of Kuwait, I believe it will be of interest to know I have arranged, at the request of the U.S. Government, for the immediate supply to the US forces from West German army inventory, 10 Fox NBC reconnaissance vehicles (capable of chemical detection and protected operation in a chemical warfare environment) and an additional option for 20 more of these vehicles. As you may be aware, neither Canada nor the US have any such anti-chemical vehicles in inventory.

The US has now asked for the Fox chemical protected personnel carriers as well. It now appears the U.S. may request all available vehicles. Before we agree to such a US request, I am offering to make such vehicles available to Canada should Canadian forces be deployed to a land base in a region threatened by chemical warfare.

If such is your desire, I would need to know as soon as possible.

I trust this is helpful to you.

As regards the Mohawk situation, I have been concerned for years, and have expressed this concern, about the known fact that certain Canadian Native groups received training in East German terrorist training camps, and I have reason to believe that some such groups may be in possession of armour-piercing weapons. There are in Shilo, Manitoba, at the Training Camp, a number of Marder personnel carriers vehicle, which offer protection against such weapons. They are being used for training the German forces

there. I could arrange, either from our company, or on a Nato country to country basis, to make these vehicles immediately available to your forces.



Karlheinz Schreiber

Suite 908, 350 Sparks Street, Ottawa, Ontario  
Telephone: (613) 563-3321 Fax: (613) 563-7648

**PERSONAL CONFIDENTIAL  
FOR HIS EYES ONLY**

3

I trust this may be helpful to you as well.

Hopefully, these conflicts will be resolved peacefully, but I wanted you to know that I am available to help in this way should it be necessary.

Sincerely,

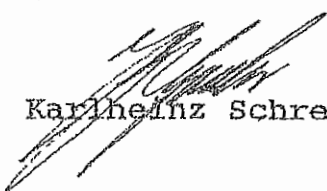

Karlheinz Schreiber

P.S. I am enclosing info on these vehicles. Obviously I am not trying to "sell" Canada anything by this offer, merely arranging to have the vehicle loaned to Canada to help protect Canadian soldiers.



**NUCLEAR, BIOLOGICAL, CHEMICAL  
RECONNAISSANCE SYSTEM  
(NBCRS)**

  
THYSSEN HENSCHEL

**GENERAL DYNAMICS**  
*Land Systems Division*



## WORLD CLASS TEAM

### GENERAL DYNAMICS AND THYSSEN HENSCHEL HAVE TEAMED TO MEET THE U.S. ARMY'S IMMEDIATE OPERATIONAL NEED TO COUNTER THE GROWING NBC THREAT.

Airland Battle doctrine requires continuous operations on the contaminated battlefield. The ability to quickly detect, identify, and quantify a wide variety of contaminants, coupled with the ability to rapidly communicate this information to friendly forces, could decide the outcome of the conflict. That operational capability is missing today.

An operational vehicle system that can respond to this need is available now from a proven industrial team of General Dynamics Land Systems and Thyssen Henschel.

The FOX NBC Reconnaissance System (NBCRS) is the only operational system of its kind in the free world. Thyssen Henschel has produced more than 140 FOX NBCRS configured vehicles that are currently fielded and used by the West Germany Army. In addition, over 1000 FOX combat, combat support, and combat service support vehicles have been produced and fielded to support NATO forces.

The FOX NBCRS is a highly mobile, amphibious wheeled vehicle, tailored to meet the operational requirements for NBC Reconnaissance on the current battlefield. It is the only operational NBC Reconnaissance System in use by NATO forces today.

The FOX NBCRS is already playing a key role in the defense of Europe.

Thyssen Henschel has a long history of combat vehicle development and production. Today the company designs and builds some of the most sophisticated armored combat, communications, missile, and command systems for the West German Army and other NATO allies.

General Dynamics brings the experience of decades of design, integration, and production of defense systems. GD has designed, built, and supports a wide range of advanced weapon systems including the F-16 aircraft, the Stinger Missile, and the M1 series Main Battle Tank.

The combined resources of this team has resulted in a program to provide a proven NBCRS system that meets today's requirements with planned growth for future NBC defense requirements. The proposed program offers a low risk approach, based on using an NBCRS that has been fielded and in operation since 1984.

The baseline NBCRS will be expanded during a system improvement program that is based on current Army combat vehicle command and control electronics technology as well as the latest NBC detection technology.

### TRANSITIONING NATO TECHNOLOGY INTO THE U.S. ARMY PRODUCTION BASE

The FOX NBCRS meets today's demand for a high performance armored vehicle tailored to accomplish the NBC Reconnaissance Mission.

The FOX system is fully developed and proven. The integrated Non-developmental Item (NDI) nuclear, and chemical detection, identification, location, and marking system is currently playing a role in the defense of Western Europe. The current FOX system provides a baseline for evolutionary improvement with low technical risk.

For full rate production, the FOX NBCRS will integrate all of the developed and tested

improvements necessary to provide a mobile standoff sensing capability for detecting, identifying, and reporting all NBC threats.

The improved FOX will be based on an electronics architecture that will integrate all NBC detectors, the Position - Navigation (Pos/Nav) system, and meteorological sensors, with a digital burst communications capability via an integrated computer processing unit.

System upgrades can be retrofitted to the current FOX NBCRS with no degradation to system performance or RAM characteristics.



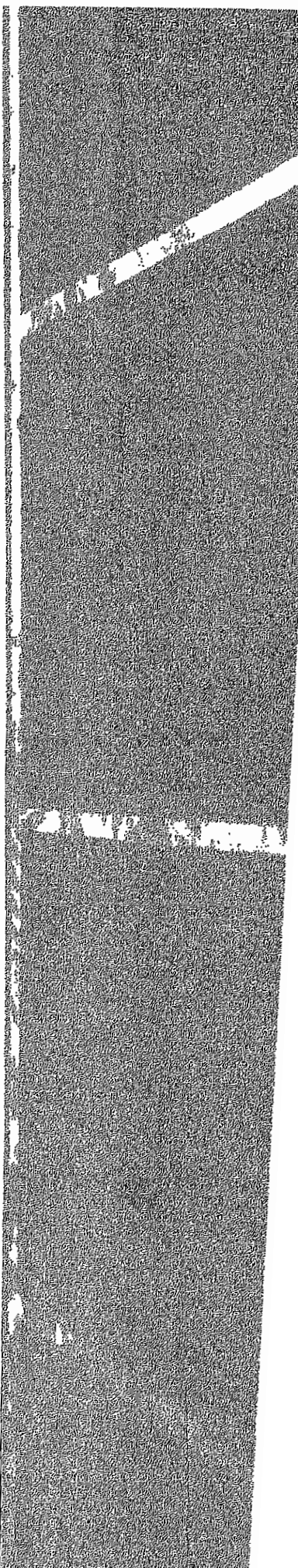
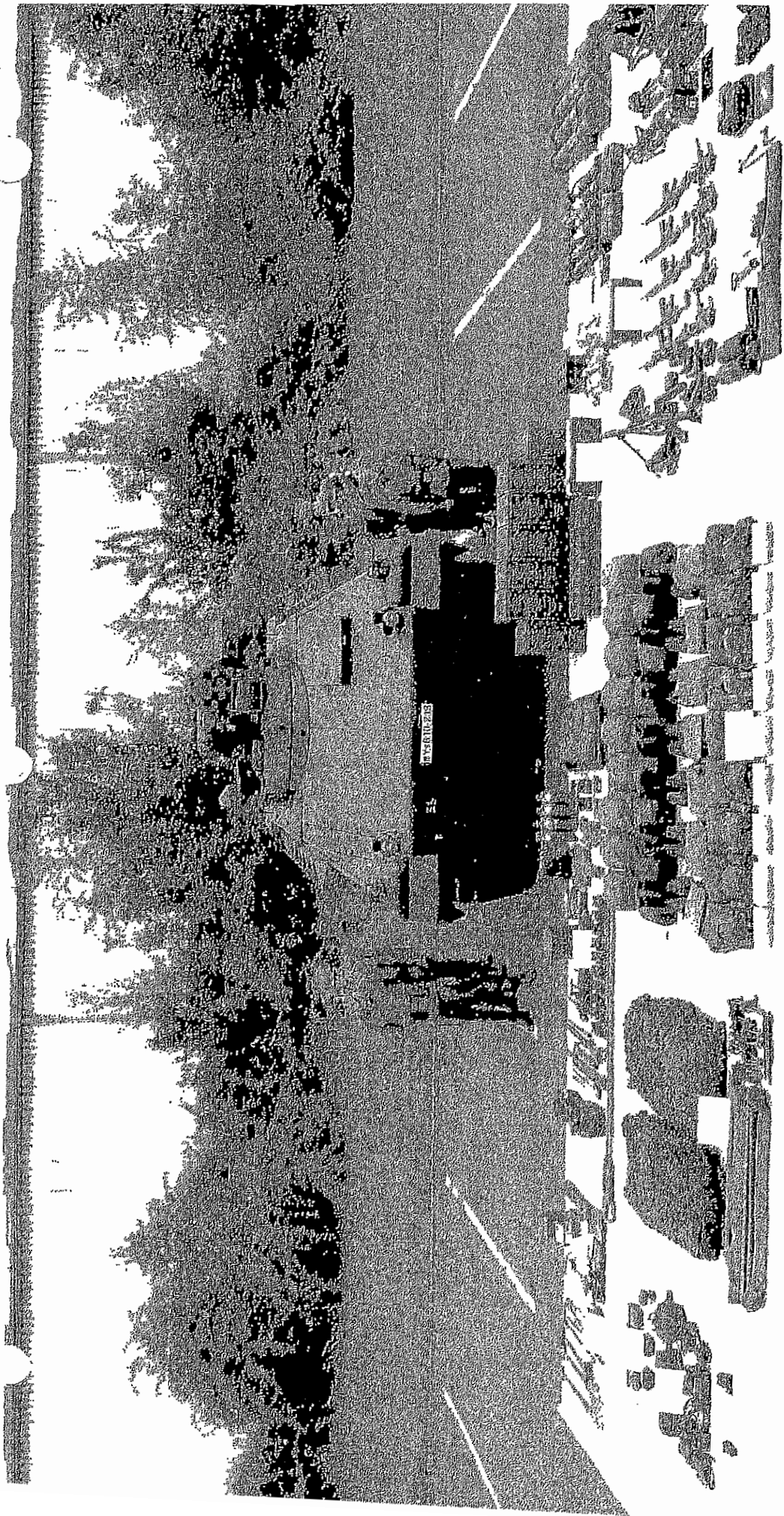



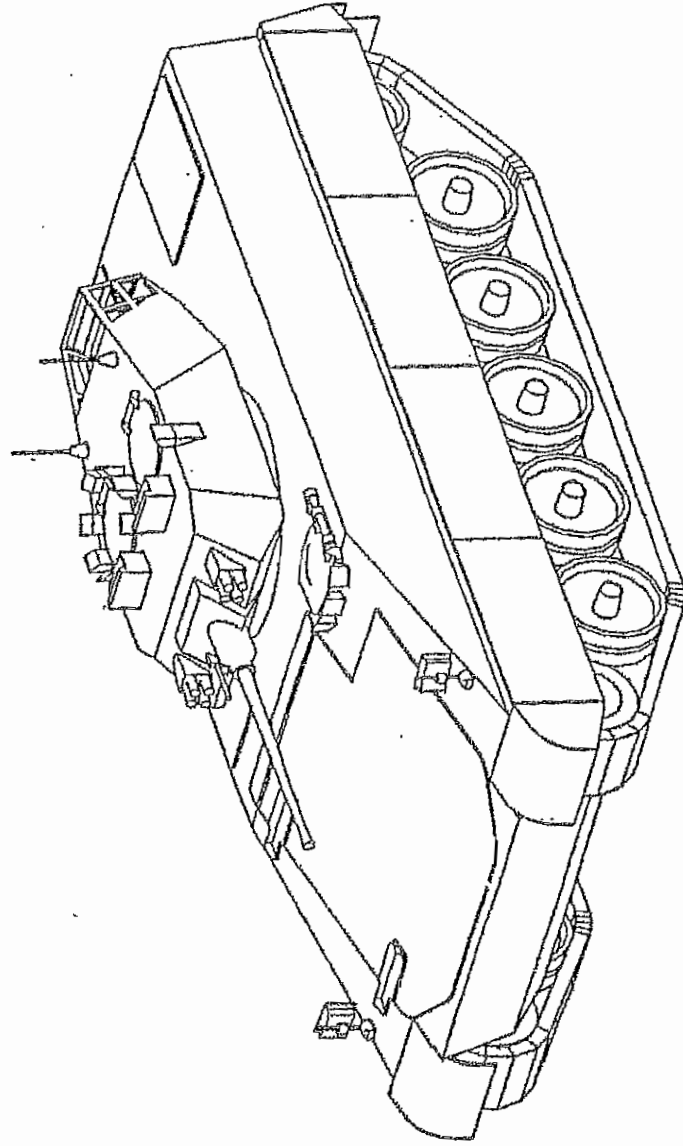

TH 495

WITH TURRET LAV 25 MM

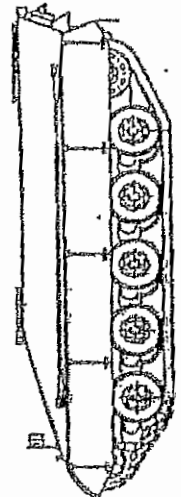

T H 4 9 5  
CARRIER

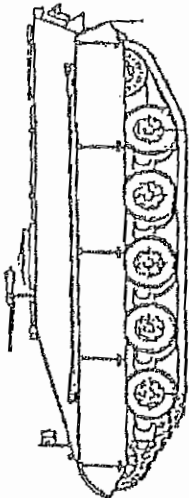

T H 4 9 5  
INFANTRY-VEHICLE, with MG 7.62 pin-mounted

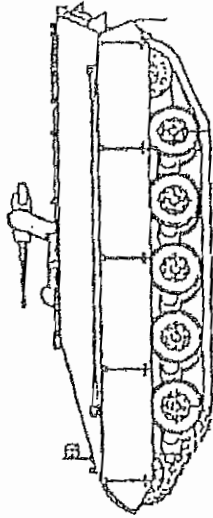

T H 4 9 5  
INFANTRY-VEHICLE, with MG 12.7 Cupola

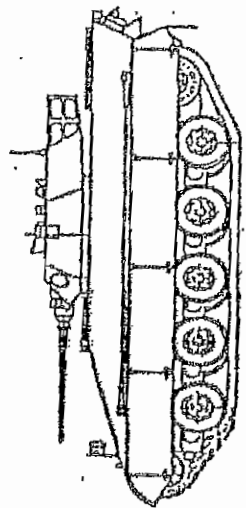

T H 4 9 5  
INFANTRY-FIGHTING-VEHICLE, with main gun 25 mm

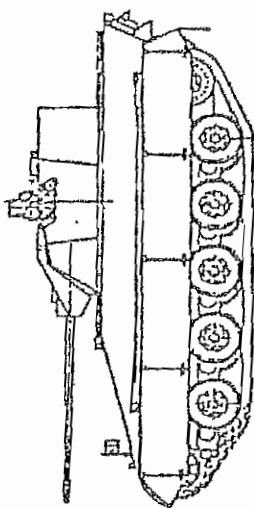

T H 4 9 5  
INFANTRY-FIGHTING-VEHICLE, with main gun 35/50 mm

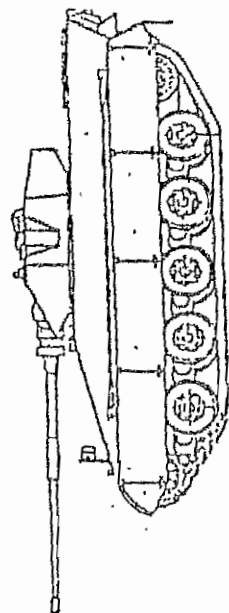

T H 4 9 5  
INFANTRY-FIGHTING-VEHICLE, with BK 60 mm

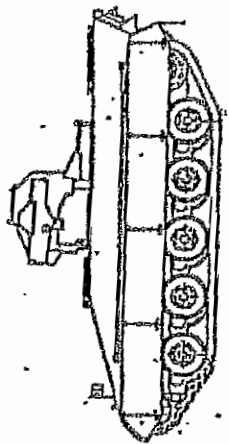

T H 4 9 5  
INFANTRY-VEHICLE, with armored launching turret for the TOW Missile System

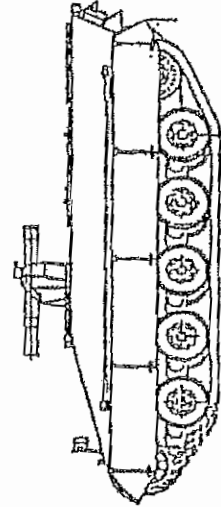

T H 4 9 5  
TANK HUNTER, with TOW-launcher





CONFIDENTIAL

63

MEMORANDUM

1000-1 (DDIR 4)

Oct 90

ADM(Mat)

THYSSEN INDUSTRIES AG PROPOSAL  
TO SUPPLY DND WITH 250 MULTI-ROLE  
COMBAT VEHICLES (MRCV)

Refs: A. 1000-1 (DGSPDI) 24 Jul 90  
B. 1000-1 (DDIR 4) Sep 90

1. Ref A covered a Briefing Note to the DM dealing with the Thyssen proposal to supply DND with 250 MRCV (the Thyssen Fox) via a sole-source directed contract as a prerequisite to their establishing a production facility for their Canadian subsidiary, Bear Head Industries Ltd., in Cape Breton. Ref B was an update of that briefing note and addition of an Executive Summary. It is understood that those Briefing Notes were used for sundry meetings between Ministers and/or senior officials.

2. Enclosed find a further update to that Briefing Note, together with a forwarding memo to DG Exec Sec for your approval and signature. The Briefing note, unchanged in substance from earlier iterations, is intended for use by MND and senior DND officials involved in the 1 Nov 90 meeting with the Honourable Elmer MacKay and Mr. Norman Spector.

3. It is our present understanding that the 1 Nov 90 meeting was prompted by MND's office and that its purpose is to make clear once and for all DND's opposition to a directed contract to Bear Head Industries. As a bonus, this meeting will draw Mr. Spector into the loop and equip him to run interference between lobbyists for BHI and the Prime Minister. It has been suggested that, while MND's office has been fighting the BHI proposal, some military

.../2

CONFIDENTIAL

34122284

34122284

307

CONFIDENTIAL

- 2 -

staffs have been conveying the idea that they really would like the Thyssen vehicle if only they had the money; in short, the claim is made that mixed signals are being sent. There is no apparent basis for such a claim. CLDO has been tasked by CDS to attend the meeting and to present in unequivocal terms the user's view. We also understand that Cliff Mackay will be in attendance, as will Mr. Carl-Heinz Schrieber, Chairman of BHI.

4. DND's purpose in calling the meeting may not be entirely clear to ACOA. From staff level discussions, it is understood that Mr. MacKay has had a number of discussions with BHI on the matter, that he may have signed some re-iteration of the 1988 Understanding in Principle as recently as last August, that ACOA see the meeting as an opportunity to move the file along, and that their hope for the outcome of the meeting is agreement by MND to a directed and immediate contract to BHI.

5. The conclusion continues to be that the Department should strongly oppose a directed, sole-source contract to Thyssen/Bear Head Industries.

R.N. Sturgeon  
CS  
992-6523

Enclosures: 2

CONFIDENTIAL

... 25  
34120285-  
208

R.N. Sturgeon  
CS  
992-6523

Enclosures: 2

Recommended for Signature:

ORIGINAL SIGNED BY

Col J.E.C. Lavoie/DDIR/998-7088

(Date)

ORIGINAL SIGNED BY

T.M. Williams/DGSPDI/992-5715

(Date)

ORIGINAL SIGNED BY:

MGen G.M. Reay/CLDO/990-8447

(Date)

ORIGINAL SIGNED BY

MGen W.R. Oldford/CEM/992-3676

(Date)

34120288

34120288

309

SECRET

NOTE TO FILE : DND MEETING CONCERNING BEARHEAD/THYSSEN  
PROPOSAL ON MRCV (81)(d)

5 Nov 90

## ATTENDEES

LCOL E. Champagne, DDIR 4, 998-7081 Chair  
 Dr. C. Cannizzo, DDIR 4-4, 998-7082 Secy  
 Mr. P. Herring, DDIR 4-3, 990-6343  
 LCOL M.S. Campbell, DMFP 4, 996-6354  
 LCOL J. Trepanier, DCDS Coord Sec 3, 995-0757  
 Mrs. M.C. Dupuis, PROC/FIN Mngr, 992-5872  
 MAJ M.N.G. Hutton, DLR 3/PDMRCV, 996-5244  
 COL W. Brewer, PM MRCV, 996-5244

## PURPOSE

1. To coordinate work for ADM(Mat) tasking for the DND draft position paper on the possibility of a directed contract to Bearhead/Thyssen for over 200 MRCVs. This paper will ultimately become part of the Atlantic Canada Opportunities Agency's (ACOA) briefing for the Prime Minister's office.

## BACKGROUND

2. LCOL Champagne opened the meeting by providing a briefing on the history on the Bearhead/Thyssen (BHI/T) issue and on the current tasking.

3. The current tasking arises from a meeting held 1 Nov 90, attended by MND, Elmer Mackay (ACOA Minister), Norman Spector (COS for Prime Minister), Peter Smith (VP, ACOA), ISTC political staff, ADM(Mat), and CLDO. From DND's perspective, this meeting was to put paid to the various efforts by BHI/T to inveigle a directed contract from DND, efforts dating back to 1984 as well as to bring Mr. Spector up to speed and on side. Unfortunately, the outcome was somewhat different. Mr. Spector directed that the Prime Minister's Office (PMO) wanted a briefing that provided the costs of going ahead, rather than arguments for not proceeding, as had been previously provided.

4. A follow-on meeting of ADM(Mat), Cliff Mackay, ADM at ISTC, and Peter Smith was held later that same day. They agreed to produce a paper for the PMO which would change the thrust to the costs of proceeding. (See enclosed letter Smith to Gillespie.)

SECRET

OTT/SOC/CCS

3412J292

3/0

SECRET

- 2 -

5. ACOA has the lead for preparing the brief for the PMO. While DND's preferred strategy is to withhold providing our input to ACOA until ACOA has received a business plan from BHI/T, this may not be tenable, and it is likely that our input will be provided next week, after approval by ADM(Mat), whether or not a business plan or formal proposal by BHI/T is available. Our input will be incorporated intact into the ACOA paper. The final ACOA brief will be signed by ACOA, ISTC, and DND (signing level TBA).

6. MND and ADM(Mat) have noted that it is imperative that we do not lose this one. The Department must speak with one voice. Thus, we must coordinate our response/input for ACOA within DND.

7. ADM(Mat) has noted the following points, inter alia, which should be incorporated into our analysis:

- a. re-present DND case, but with new angle;
- b. CR 90--ie, where we are now;
- c. fragility of MRCV program;
- d. effect on DPMS (what could be driven to the right; impact on other army programs; impact on other programs);
- e. existing cash flow;
- f. spares (be liberal in allowance);
- g. impact on industry; and
- h. problems (costs) of fleet rationalization; incremental costs to support mixed fleet.

Our format should divide the various costs into categories, ie: operational, financial, defence industrial base, defence policy review considerations, and international. AGREED.

8. While the latest BHI/T proposal is not clear, we should assume that the Jul 89 proposal holds: over 200 vehicles [assume 250 for purposes of this exercise] at a cost (contract) of \$250M, with production to begin in early 93.

9. The proposed site for the production facility has apparently been changed from Bearhead in Cape Breton to Central Nova. Thus, the Cape Breton investment tax credits are off the table.

10. ACOA's position is reportedly "judiciously sceptical". They would like to sponsor this project very much, but want to be sure of the long term viability of the facility (ie, no long term dependence on DND orders) and they want DND on side. ACOA's part in the exercise will be to analyze the

SECRET

OTT/SUC/CCS

34120293 -

6, 11

SECRET

- 3 -

business plan, as well as prepare the final paper. Contact: John McDowell.

11. ISTC's part will be to focus on tax issues, if any, and on the question of industrial base capacity in the sector. Contact: Leah Clark.

12. DGSPDI, Mr. M. Williams, joined the meeting briefly and made the following points:

- a. Mr. McDowell has written a section on operational costs based on his discussion with GEN Reay, CLDO, and will be faxing this to us;
- b. he should be informed that DND will write this section; we will not simply "comment" on his draft;
- c. the paper for the PM may have to be ready for Ops meeting in two weeks; and
- d. ADM(Mat) has given emphatic direction that everything to do with this subject is on very close hold and personnel involved are to refrain from discussing the matter except on a clear need to know basis.

## DISCUSSION

13. The following points were raised:

- a. project cost for MRCV is \$2.5B already;
- b. to pull project into 93, would have to do PD today;
- c. splitting the project into 2 pieces (ie, the 250 then the remaining 485) would double such costs as technical manuals; everything would have to be done twice if some other company receives the contract for the remaining 485;
- d. could not achieve economies of scale on spares or anything else;
- e. competing the rest would tend to favour BHI/T from logistics/operational and cost points of view, so it really wouldn't be a competition afterall;

SECRET

OTT/SOC/CCS

34123294-312

SECRET

- 4 -

- f. can't get a plant built and running in 2 years; would take 2 years to tool-up, man, and acquire materiel for an established production line; ie, at least 18 months to get proper steel;
  - g. this would reverse the order in which the Army needs the various variants: need Lynx replacement--the Recce Combat Vehicle (RCV)--~~now~~ since no more support available; Fox fits the Infantry CV profile which we don't need for 6 years; if cash crunch comes and we have bought Fox, we could lose the RCV and the Armoured CV; Army has been working for years to get their new family of vehicles properly sequenced; and
  - h. how would this fit in with Defence Review?
14. The following simplifying assumptions were made:
- a. the "buy" would be 250 vehicles, Thyssen's Fox, for a contract cost of a minimum of \$250M in 89 dollars; this would translate into a project cost for this section of about, e.g., \$600M;
  - b. production would start in the latter half of FY 92/93;
  - c. a figure will be calculated for an estimated new total project cost; ie, current estimate is \$2.5B, but splitting it in this way would raise the cost to, e.g., \$3.0B; and
  - d. the results of a-c can then be fed into the DPMS analysis to provide some "what ifs", ie, what might have to be chopped/delayed/downsized to make room (ADM(Mat) suggested TCCCS as one example); a full scale analysis of the effects on the DPMS is clearly not possible in the time available, so we will have to make do with some dramatic, but justifiable, what ifs.
15. The following ACTION ITEMS were agreed:
- a. COL Brewer, MAJ Hutton and Mrs. Dupuis will provide a cost estimate for the directed contract project (ie, the 200 Fox) and for the new increased total project cost to LCOLs Trepanier and Campbell on 6 Nov, including a cash line;

SECRET

077/SDD/CCS

34120295

71

SECRET

- 15 -

- b. LCOLs Trepanier and Campbell will conduct the DPMS analysis;
- c. Cannizzo will draft the section on "operational costs" and then go over it with MAJ Hutton on 6 Nov;
- d. persons in a and b above will provide appropriate paragraphs to Dr. Cannizzo for the "financial costs" section (on either 3 1/4 " floppy or 2" diskette in Word Perfect) NLT 1300 on Thurs, 8 Nov;
- e. we will have a progress meeting 0700 (still 0-dark-30 for some of us!) on Wed 7 Nov in DDIR Conference room, 6 NT (ITEM: who signs off when? ie, CS, CLDO before it goes to ADM(Mat), or can signoffs come before it goes to ACOA?)
- f. Cannizzo will draft the sections on "defence industrial base", "defence policy review " and "international" costs, and then put all the pieces together NLT morning of 9 Nov; and
- g. LCOL Champagne and COL Lavoie, DDIR, will review in the morning of 9 Nov, and the draft will be presented to DGSPDI on the afternoon of 9 Nov and thence to ADM(Mat).

SECRET

3/4  
UTT/SDD/CDS

34120296 -





Ministre des Travaux publics



Minister of Public Works

October 17, 1990

Dear Brian:

With all that has been going on lately I have been reluctant even to call you to discuss a few matters down east, principally the Thyssen project.

When you have an opportunity in the next day or so, would you mind if I call you or perhaps you could ask someone to leave word with my staff as to when it might be convenient.

I am going to Nova Scotia later today and I will be there for the weekend. I shall be linking up with Bill McKnight who will be visiting Halifax and speaking at my Annual Meeting.

Yours sincerely,

Elmer MacKay

The Rt.Hon. Brian Mulroney  
Prime Minister of Canada  
House of Commons  
Ottawa, Ontario.



68



ASSISTANT DEPUTY MINISTER (MATERIEL)

SOUS-MINISTRE ADJOINT (MATÉRIELS)

SECRET

DM

THYSSEN FOLLOW-UP

- ACOA is bringing the original and only copy of the "business plan" over for me to read at 2 p.m. this afternoon.
- [ In arranging this last night with Peter Smith, I was informed that the draft MC (that paper that we have received from ACOA) had been circulated yesterday to at least PCO, TBS and SSC (maybe also DEA) along with a draft RD! This was done just in case Mr. Mackay decides to walk the paper in to Cabinet Committee in the "next week to ten days" without the DND portion.
- I have spoken to both TBS (O'Connor) and PCO (Billings) to clarify their views and to ensure they understood what we are doing. Billings, in fact, called me before I could call them. They have issued a blunt message to ACOA to withdraw all copies and shred them. ACOA is being informed that they are way out of line. PCO has spoken to Spector and clarified his expectations which are a joint paper to go to the PMO before anybody starts tabling MCs.

.../2

SECRET

*noted*  
*[Signature]*



ASSISTANT DEPUTY MINISTER (MATERIEL)

SOUS-MINISTRE ADJOINT (MATÉRIELS)

SECRET

- 2 -

- I indicated again to Jane that this as a proposal would have drastic consequences for DND and that if pushed much harder in the current fashion may require you to speak to the Clerk. I did not lay out the points that you might make that we discussed yesterday, i.e. serious exposure to ridicule on several fronts, etc., etc. She said they understand that this is a very difficult issue for DND and will insist on due process.
- Bottom line - we are continuing to get a suitable paper prepared as soon as possible (end of next week?). I will let you know if I see any further developments which would suggest your intervention is required.

cc: CS

ORIGINAL SIGNED BY  
COPIE ORIGINALE SIGNÉE PAR  
R. D. GILLESPIE

R.D. Gillespie  
992-6622

30 Nov 90

SECRET



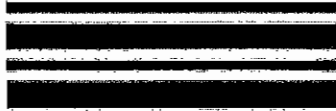

# SUPERText



## RCMP "A" DIVISION COMMERCIAL CRIME

File: A102  
95A-517

### EXHIBIT INFORMATION

DATE OBTAINED: \_\_\_\_\_  
Obtained By: \_\_\_\_\_  
Exhibit No.: 96-34  
Item No.: \_\_\_\_\_  
Location: \_\_\_\_\_

### DOCUMENT CATEGORIZATION

Document Type: \_\_\_\_\_  
Original: Yes \_\_\_\_\_ No

258-260-262-265-  
277-282-286-295-  
297-300-302-304-308-  
311-319-321-325-327-329-  
342-346-349-350-352-  
355-357-361-364-368-  
370

COMMENTS HCOA documents extracted  
from items 16 to 57  
stapled

Clone: 8-11-16-19-25-27-30-47-55-63-  
65-70-77-88-90-93-97-100-  
104-107-110-113-122-126-131-138-  
140-144-146-149-151-160-164-180-182-  
191-195-198-204-207-211-215-222-222-  
225-228-236-240-245-247-247-253





North American markets, under the Canada/United States Free Trade Agreement and the Defence Production Sharing Agreement;

b) transfer to the facility, all technology necessary for the establishment and development of this facility and its respective specialized products in both the civilian and defence sector;

c) to the greatest extent possible, source its requirements from, and promote the establishment of source capabilities small business enterprises located in Atlantic Canada;

d) employ a minimum of 500 people on a permanent, full-time basis and, where necessary, train these individuals in required skills and knowledge, utilizing, where appropriate, local educational facilities.

2. In accordance with this MOU, the Government of Canada, in order to facilitate the establishment of the Company's heavy-industry manufacturing activity in Nova Scotia, will:

a) enter into negotiations with the Province of Nova Scotia, to put in place financial arrangements for the co-funding of required physical infrastructure, up to a maximum value of \$15 million;

b) entertain an application by the Company to the Minister of National Revenue for duty remission on the importation of machinery, parts, and components for the manufacturing of vehicles, under the Machinery and Equipment Tariff Program, consistent with this program at the time of such importation; and

c) entertain an application by the Company to the Minister of Employment and Immigration for Government participatory funding, for initial employee training.

3. In recognition of the need to proceed urgently, the Government of Canada and the Company agree to adopt a two-phased approach to the establishment of the facility.

#### PHASE I

4. The Government of Canada and Company agree that in Phase I, the respective parties will undertake the following:

3

a) the Company

(i) the Company will proceed forthwith with the construction of an initial plant, requiring an estimated initial capital investment of \$68 million, to manufacture defence products for the North American markets;

(ii) the Company will sub-contract manufacturing of major components for supply to the Thyssen Henschel - General Dynamics Land Systems joint venture which has recently been awarded contracts for the supply of TPZ Fox armoured vehicles to the United States Army.

b) the Government of Canada:

(i) The Minister of National Defence, will place a sole sourced order with the Company for 250 Fox (TPZ Fuchs) Armoured Personnel Carriers, from Canadian production at the Company's Nova Scotia facility.

[BHI estimates the cost for these 250 vehicles at approximately \$210 million Canadian, based on current and previous sales to the German and U.S. Armies. After DND specifications are established, final price will be determined using the principle of open audit of costs and agreed profit.]

provided the Company:

- a) manufactures in its Nova Scotia facility, these vehicles from its entire technology range according to the operational requirements of the Government of Canada,
- b) meets the Government's requirements for quality, delivery, and logistic support, including personnel training,
- c) provides acceptable regional and industrial benefits;
- d) agrees to announce and proceed immediately with construction of it's plant with the following schedule:

- Nov. 1990: Contract signed with Government of Canada
- Jan. 1991: Engineering finalization and commencement of construction contracts.
- Oct. 1992: Plant in operation and staffed.
- Oct. 1993: - Commencement of delivery of vehicle  
- Commencement of Phase II diversification.
- May 1995: Completion of delivery of vehicles.

e) BHI agrees that DND may, until September 1991, cancel all or part of its order and replace it with an order of corresponding value for Multi Role Combat Vehicles (TH495 category).

PHASE II

5. The Government of Canada and Company further agree that in Phase II, the respective parties will undertake the following:

a) the Company

(i) the Company will proceed not later than twelve (12) months after the commencement of production under Phase I, with diversification into heavy civilian manufacturing production targeted at Canadian and international markets, for environmental protection technology; and

(ii) the Company will provide within six (6) months after the commencement of production under Phase I, financial details including product and market projections associated with Phase II; and

(iii) should Phase II not be proceeded with, the Company will reimburse the Government of Canada for a portion, to be determined in subsequent negotiations, of the infrastructure assistance provided under paragraph 2 (a) above, in the event that the employment level of 400 people for Phase I is not sustained for 5 years.

b) the Government of Canada:

the ACOA Minister, will consider assistance to the Company, under established regional and industrial development programming, consistent with such programs at the time the project becomes eligible for such assistance.

6. In recognition of the very considerable financial, technical, and other capabilities realized by Bear Head Industries, as a wholly-owned subsidiary of Thyssen Industrie AG, and the importance of such capabilities to the Government of Canada, by copy of the enclosed agreement between Thyssen Industrie AG and Bear Head Industries, Bear Head Industries hereby discloses a commitment by its parent to retain its one hundred percent ownership in Bear Head Industries, for a period of at least five years in duration, commencing from the date of the award of the contract (noted in paragraph 4b (i) above) to Bear Head Industries.

Should Thyssen Industrie AG wish to divest, in whole or in part, its holdings of Bear Head Industries, prior to 5 years, Bear Head Industries will in advance seek written consent from ACOA, and will remit to the Government of Canada a sum equal to fifty percent of the aggregate value of the federal contribution to infrastructure (noted in paragraph 2a above).

THE GOVERNMENT OF CANADA

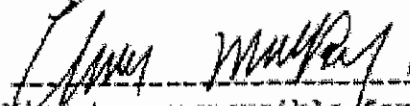

Minister responsible for the  
Atlantic Canada Opportunities Agency

Minister of National Defence

BEAR HEAD INDUSTRIES LIMITED

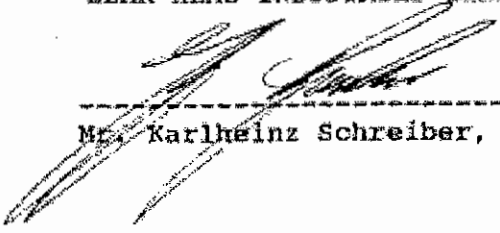

Mr. Karlheinz Schreiber, Chairman



CS  
DGS PDI  
DIA ✓  
C. Paul  
30/11

W

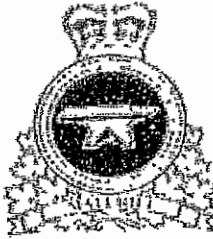

ASSISTANT DEPUTY MINISTER (MATERIEL)  
SOUS-MINISTRE ADJOINT (MATÉRIELS)

SECRET

CS

BHI

Further to the note that we sent this morning, Jane Billings from PCO called. They realized yesterday when they received the paper plus a draft RD that this was being distributed all over town. They are currently contacting ACOA and all recipients of the paper with the exception of DND, who is involved in writing it, instructing withdrawal and shredding of the copies including the RD. They have also spoken to Spector to confirm that this is not what he expected to happen. It is not. He is expecting a joint paper which would be something that went to the PMO before anybody started writing submissions. Bottom line - ACOA is receiving a very blunt message from PCO. We are continuing on our current track.

(2)  
DIA ✓  
Noted - thank you  
J E C. Lofchie  
DND / DND  
30/11

ORIGINAL SIGNED BY  
COPIE ORIGINALE SIGNÉE PAR  
R. D. GILLESPIE

R.D. Gillespie  
992-6622

30 Nov 90

SECRET



*à discuter  
avec J.G.  
avant de savoir  
si on en est.  
C.T.  
11/12/90*

CLERK OF THE PRIVY COUNCIL AND  
SECRETARY TO THE CABINET



DREFFIER DU CONSEIL PRIVÉ ET  
SECRETAIRES DU CABINET

SECRET

December 10, 1990

MEMORANDUM FOR NORMAN SPECTOR

Thyssen/Bear Head Industries

Attached is an aide-memoire on Thyssen's Bear Head Industries proposal, prepared by the Atlantic Canada Opportunities Agency (ACOA) with input from National Defence, External Affairs and ISTC. The paper responds to the request you made when you met with Ministers MacKay and McKnight on November 1 for a joint paper describing what would be necessary for this project to go ahead in the near future.

Summary

Thyssen is proposing that the Government purchase 250 of its TPZ "Fox" military vehicles, at a cost of \$290 million, by means of a directed contract, with delivery beginning in 1993/94. In order to produce these vehicles, Thyssen would invest \$61 million in building a new, major facility in Nova Scotia which would employ on average 600 persons over the next seven years. In addition to the directed contract, Thyssen is asking for \$12.2 million in federal and provincial assistance and tax credits. Thyssen is looking for a decision by the end of 1990.

ACOA is strongly supportive of the Thyssen proposal on the basis of anticipated regional benefits and argues that the proposal is commercially viable. It points out that the Government has used directed contracts on a number of occasions to support regional growth and development, although in this instance the contract would involve a "green field" or new establishment.

DND notes that going ahead with this proposal would involve: additional costs of \$765 million over and above the \$290 million already budgeted; the need to fit the Fox into the not-yet-completed defence policy, and the loss of the potential for fleet rationalization. On operational grounds, among other concerns DND has indicated that the Fox is not air transportable. The Thyssen proposal does include an option for DND to purchase its next generation TH 495 vehicle; however, this vehicle is still on the drawing board and has been neither tested nor costed.



The paper also reflects comments from ISTC, on the fit with industrial policy and the ability to maximize industrial benefits with a directed contract of this nature, and from External Affairs on the likely impact of such a purchase on relations with the United States on defence procurement. It should be noted that the line departments have provided input only; they have not signed off on the document.

Comment

As you requested, the aide-memoire does lay out what would be necessary for this project to go ahead: the price is very high, with DND purchasing equipment it basically does not want in a time-frame that does not suit its needs. Although ACOA views the resulting facility to be viable, DND feels that there is not enough information within the Thyssen business plan to justify this conclusion. (No other departments have seen the plan.) At approximately \$2 million per job, the Government would want to be very sure the plant would succeed.

I understand that you will be discussing with Mr. MacKay how to proceed on this project. He is very anxious to have this matter scheduled for Operations Committee in the near future, possibly on December 13. If this is the case, we will prepare more detailed briefing material for that meeting.



Paul M. Tellier

Attachment

Billings/Bilodeau/de

14:00

SECRET  
10.12.90

THYSSEN/BEAR HEAD INDUSTRIES FACILITY IN NOVA SCOTIA

TABLE OF CONTENTS

	<u>PAGE</u>
- ISSUE . . . . .	2
- PROPOSAL . . . . .	2
- FINANCIAL IMPLICATIONS . . . . .	2
- DND PERSPECTIVE . . . . .	3
- ACOA PERSPECTIVE . . . . .	4
- OTHER DEPARTMENTAL POSITIONS . . . . .	6
- NEXT STEPS/CONCLUSIONS . . . . .	7
- ANNEX A - DND ANALYSIS OF THE THYSSEN PROPOSAL	
- ANNEX B - THE COMPANY/BACKGROUND	
- ANNEX C - THYSSEN'S ESTIMATE OF FORECAST REVENUES FOR BHI	
- ANNEX D - THYSSEN'S ESTIMATE OF FORECAST REVENUES (FLUE GAS SCRUBBER) FOR BHI	
- ANNEX E - THYSSEN/BEAR HEAD INDUSTRIES MARKETS	
- ANNEX F - EMPLOYMENT PROJECTIONS	

ISSUE: Whether to support the proposal by Bear Head Industries Limited, (a subsidiary of Thyssen) for a directed contract in order to establish a heavy manufacturing facility in Nova Scotia.

PROPOSAL: Thyssen is seeking a directed contract for 250 of its TPZ "Fox" military vehicles, at a cost of \$290 million (1990 dollars), with delivery beginning in FY 1993/1994. Thyssen is targeting the DND multi-role combat vehicle (MRCV) project. Within one year of signing this contract, DND may, after negotiations with the company, switch the order and purchase instead an unspecified quantity of Thyssen's next-generation TH 495 vehicles for an unspecified price.

Thyssen is proposing to invest \$61 million by 1994 to construct a major facility in Nova Scotia to produce military vehicles, and environmental products. The company predicts employment will reach 300 by 1993/94, and average some 600 persons over the first seven years of operation. The company will support its facility with royalty-free technology transfer.

Thyssen is also seeking \$12.2 million of assistance for off-site infrastructure (to be cost-shared between the federal and Nova Scotia governments), and pro forma investment tax credits.

The company has indicated that it must reach a decision on whether or not to proceed by the end of 1990.

FINANCIAL IMPLICATIONS: Financial implications for the federal Government are very significant (about \$1.1 billion), comprising primarily funds already budgeted by DND for the program element (\$290 million, budgeted after the year 2000), incremental costs estimated by DND to support the Thyssen proposal (\$765 million), and the much smaller (approximately \$8 million) costs of federally-funded infrastructure. (All financial data below are provided in 1990/91 dollars.) Specifically, costs include:

- (1) expenditures on Thyssen contract for 250 vehicles: \$290 million;
- (2) DND's estimate of additional costs of Thyssen proposal over and above those already budgeted (\$290 million, after the year 2000) for infantry combat vehicle portion of MRCV project:
  - a) \$435 million in capital (spares, training, project management, etc.),
  - b) \$130 million in unforecasted O&M for the additional vehicles, and
  - c) \$200 million for inefficiencies and lack of fleet rationalization;

- (3) \$8 million for federally-funded infrastructure (sewer, rail, hydro, etc.), assuming the province of Nova Scotia bears remaining 30 percent, or \$3.6 million; and
- (4) pro-forma investment tax credits (maximum 15% of eligible investment for mainland Nova Scotia site).

DEPARTMENT OF NATIONAL DEFENCE (DND) PERSPECTIVE: The detailed assessment by DND of the proposal is included in Annex A.

In summary, DND indicates that if it were directed to proceed with the Thyssen proposal at this time, the department and the army would face a daunting task to fit the Fox (or the proposed TH 495) vehicles into a not-yet-complete policy and operational planning framework. Beyond considerations of the appropriateness of the vehicle for operational requirements, DND is seriously concerned about the affordability of this proposal in the context of other priorities; and its timing, given that the Defence Policy Review and associated capital program will not be considered by Cabinet until early next year.

DND indicates that the Fox is not the right vehicle for the Canadian Forces. The Fox is not air-transportable in a C-130 Hercules aircraft; it would not provide the necessary fleet rationalization of a "family" of like vehicles; it would result in significantly fewer vehicles (25% less than DND's minimum operational requirement) for the army; and would result in purchasing the infantry variant before it is required instead of replacing other obsolete variants. In addition, DND is unable at this time to consider the TH 495 since it is still on the drawing board and constitutes an untested and unproven design.

Although the Thyssen proposal is for 250 vehicles at a contract value assessed at \$290 million, on the basis of available business information, DND has determined that the net incremental impact on the defence budget of acquiring 250 Fox would be over \$765 million (90/91 dollars). (See para. #24 in detailed DND position, Annex A.)

During the acquisition phase (1993/94 - 97/98), this buy would create a requirement for \$655 million (90/91 dollars) in unforeseen capital cash flow, and DND is not able to identify how such an amount could be diverted from the other elements of the Defence Services Program without causing costly and disruptive dislocation to existing plans, contracts and projects. Indeed, even were such an amount of money available from sources outside DND, other priorities have much more pressing requirements on which that money should be spent. For example, previously-approved projects such as TCCCS (the army radio program, NSA (the naval helicopter), and the Northern Terrain Vehicle are currently facing affordability problems.

Finally, DND notes the exacerbation of existing overcapacity in the defence industrial base, and the likelihood of a strong negative public reaction.

ACOA PERSPECTIVE: Other departments have raised significant concerns regarding the affordability of the Thyssen proposal to DND; the perceived economic viability of the Nova Scotia facility; and the effects the Thyssen facility would have on Canada's existing military vehicle industry. Ministers will wish to consider these concerns in reaching a decision on the Thyssen proposal.

Accordingly, while the concerns raised by other departments are outlined elsewhere in this paper, the section below outlines the potential benefits to Canada and the Atlantic region arising from the Thyssen facility.

The proposed Nova Scotia facility would be a world-class manufacturing base, and offers tremendous benefits to the Atlantic region.

Thyssen is a huge world-class multinational with a major presence in Canada already (see Annex B). By locating a vehicle-manufacturing facility in Canada, Thyssen could gain access to the U.S. defence market, under the Canada-U.S. Defense Production Sharing Agreement. Moreover, a sale to the Canadian Forces would also enhance the company's credibility in marketing to U.S. armed forces.

Bear Head Industries (BHI) is a wholly-owned subsidiary of German-based Thyssen Industrie AG. BHI is incorporated in Nova Scotia, and, so far, operates a liaison office in Ottawa. BHI would be the only Canadian military vehicle producer which would use its own -- as opposed to licensed -- vehicle technology.

To date, Canada does not generally supply complete systems to the U.S., but has had a success with the General Motors light armoured vehicle. Military vehicles have posed virtually the sole opportunity for Canada to export "turn key" major military systems including vehicles, logistics support, ongoing maintenance, and so on. Canada has virtually no chance of successfully exporting a complete system in the other military, aerospace, and naval sectors. In general, Canada has tended to exploit niche subcomponent markets.

Thyssen's business plan so far -- prepared by Peat Marwick, and submitted to ACOA, on behalf of the Government -- indicates that the Nova Scotia facility will be economically viable, assuming market projections materialize. For detailed military and civilian revenue and market projections, see Annexes C and D respectively, and for descriptive detail, Annex E. (Should the

company provide more detailed financial projections, particularly on viability, this information would begin to address viability and marketing concerns raised by other departments.)

The company projects a net loss before taxes in each of 1991, and 1992, but robust income and cash flow generation thereafter. Despite its heavy investment, and early operating losses, the company forecasts the net present value of its Nova Scotia cash flow (including depreciation, and assuming a regional tax credit of 15%) at about \$14 million. (Employment forecasts are outlined in Annex F.)

Should the facility proceed, BHI would receive the necessary investment capital from its German parent, thus freeing the company from debt-service payments. All technology would be provided to the subsidiary BHI without royalties and licences.

Thyssen Industrie would transfer to BHI the full production technology for both the Fox and TH 495 vehicles, and undertake in Nova Scotia, future design, improvement, and development work in response to customer requirements. BHI would also receive the North American production mandate for the TH 495 (subject to joint production arrangements which may be required to compete successfully in the U.S.), and, the Canadian production mandate for both the Fox and TH 495 vehicles.

With respect to civilian production (see Annex D), the company only has firm projections for flue gas desulphurization projects, and as a result, other potential environmental revenues are not included. While further analysis is required, the company is, however, very optimistic that additional environmental revenues (municipal waste, composting, etc.) will also accrue, thus further strengthening its financial projections.

Should Thyssen successfully locate a major heavy-manufacturing facility in Atlantic Canada, buoyed by a robust German economy, other German investment in Canada would follow, from within the Thyssen group (for example, Thyssen Engineering's environmental technology), and possibly from other major German companies.

Thyssen has entered into an agreement with the Government of Nova Scotia in 1987 to provide land and a portion of infrastructure. Discussions with the provincial government have indicated that the provincial government will support the terms of the original agreement.

If directed by the Government of Canada, Thyssen would locate its facility on a "green-fields" site in mainland Nova Scotia, rather than the site originally contemplated in Cape Breton. As BHI has not developed precise sourcing for subcontracting, the direct and indirect regional benefits of the facility cannot be determined. However, since BHI will be supplying a military need, potential

suppliers must satisfy the Government's stringent quality assurance standards. Thyssen will actively promote source qualification in Cape Breton and elsewhere in the Atlantic region, (some of which have been identified and have already qualified under quality assurance) particularly with respect to small and medium-sized business. ACOA will aggressively assist in this regard through, for example, use of the Supplier Development element of the Action Program. Key vehicle subsystems to be sourced include automotive and electronics, and could be met by existing suppliers in Ontario, Quebec, Alberta, and British Columbia.

Moreover, in recent years, the Government of Canada has directed a number of military contracts, for regional development purposes, or to strengthen Canada's defence industrial base, or for DND operation requirements. These include:

- the production of northern terrain vehicles, a contract valued at up to \$200 million sole-sourced to Calgary-based Hagglunds-Foremost in 1988;
- the order for 199 armoured militia vehicles valued at about \$100 million directed to GM, in London, Ontario, in 1989;
- the award to Computing Devices Canada of a sole-sourced contract, worth about \$90 million, earlier this year, to produce fourteen shipboard electronic sub-systems used in the Canadian Patrol Frigates. As part of this package, CDC had earlier been granted about \$30 million by DND, to develop the system; and
- when in 1986, Litton Systems Canada Limited won the competed contract to modernize four Tribal class destroyers, under the TRUMP project, Litton was then directed to award a sole-source contract to the MIL (Davie) shipyard, in Lauzon, Quebec, for the first two ships. The value of this directed contract is estimated at \$175 million.

OTHER DEPARTMENTAL POSITIONS:

- Department of External Affairs: Based on information provided, DEA is concerned that Thyssen has not demonstrated long-term sustained economic viability through a detailed marketing plan, particularly for military markets. In this latter regard, DEA points out that both NATO and Warsaw Pact forces will have surplus military vehicles.



DEA is also concerned that by directing this major military purchase to a non-U.S. (i.e. German) source, particularly through establishment of a "green-field" site, Canada will irritate U.S. trade interests, and potentially threaten Canadian access to the large U.S. defence market. A fundamental tenet of our Defence Economic Relationship with the U.S. has been that, in return for access to their market, we would offer them the chance to compete to supply major requirements we could not meet domestically.

With respect to Thyssen's proposed environmental production, DEA notes that Canada has existing capacity in flue gas abatement (Joy Technologies, Kitchener, Ontario). Should Thyssen wish to pursue municipal organic composting opportunities, they could transfer the technology directly to the customer without the establishment of a Canadian facility.

- The Treasury Board Secretariat, supported by the Department of Finance, is concerned that the incremental costs of the Thyssen proposal, to be borne by the Department of National Defence, represent a very inefficient use of government resources at a time of fiscal restraint. Moreover, TBS and Finance have concerns that the Government is being asked to award this major contract to Thyssen on a sole-source basis, rather than following a competitive process.
- Department of Industry, Science and Technology Canada (ISTC). The Department of Industry, Science and Technology Canada notes that the military vehicle sector was initially established to supply the Department of National Defence (DND). Currently, two major companies are in production; Diesel Division - General Motors, (DDGM) in London, and UTDC, Kingston, Ontario. Both, DDGM and UTDC, rely on U.S. and Europe respectively for the supply of major components such as the power pack and suspension components, and use licensing arrangements to obtain the technology.

DDGM produces a family of light armoured wheeled vehicles in London, Ontario. DDGM has successfully supplied vehicles to DND and the U.S. Marine Corps. Following a couple of very slow years, the company was awarded the (DND) MILLAV contract July 1989 for 199 vehicles. Recently, the company signed an agreement with MOWAG of Switzerland for the delivery of approximately 400 LAV units to Saudi Arabia. This work should keep the company moderately busy until the mid 1990s. DDGM's long term plans are to become a viable supplier of light armoured tracked and wheeled vehicles.

Lavalin's recently acquired manufacturing division UTDC of Kingston, Ontario is currently producing heavy duty trucks for DND under license from Steyr of Austria. Production of the 1200 trucks has peaked, and employment is down to 250 employees. Layoffs are imminent. UTDC's long term plans are to supply DND with light support vehicles wheeled and light armoured vehicles.

Bombardier has completed two DND contracts; medium (MLVW) and light duty (Iltis) trucks and is currently not producing military trucks. Bombardier's long term plans in military vehicles is uncertain although the company has spare capacity at its Valcourt, Quebec plant. Haggglunds of Sweden and Canadian Foremost, to produce the northern terrain vehicle for DND, also known as the BV 206. Currently, the company is actively involved in the definition phase of the project.

Defence markets are expected to decline leading to major restructuring of both American and European defence industries. In Canada, a number of major Crown projects have been cancelled, others indefinitely delayed, and or drastically reduced in scope and budget dollars. Canada's NATO partners are facing similar conditions. Export potential is limited. Canada has overcapacity in the military vehicle sector and DND's limited and periodic acquisitions are not sufficient to justify additional capacity. Both of DDGM and UTDC, if they are to continue defence production, will need export sales.

At the company's request, ISTC has so far not had access to the business plan for the facility, ISTC has been unable to make assertions about the expected long-run viability of the facility or associated benefits related to jobs, technology, investment or exports. ISTC notes that the company should reach a decision on plant location, and thereby clarify its intentions regarding the potential use of the Cape Breton Investment Tax Credit.

The BHI proposal would increase Canada's current overcapacity in the military vehicles sector, and be contrary to ISTC's policy to discourage "green field" facilities in this sector. The proposal is also contrary to industrial benefits policy because it does not require, before acceptance of an offer, that the company provide detailed proposals with performance guarantees to be assessed against industrial benefit criteria as has been the case for other procurement.

Foreign companies may still be encouraged to invest in the military vehicles sector provided they offer significant technological and financial resources, teamed with Canadian companies to utilize existing manufacturing assets and jointly develop export markets. Teaming could broaden the product

range offered by Canadian industry, ensuring a range of advanced military and commercial products for export. New products and access to the global market place are essential to the well being of this sector.

NEXT STEPS: There is a need for further discussion of the proposal. Should Ministers wish to proceed with discussions, the following course of action could be pursued:

- meeting between Ministers MacKay, McKnight, and others as required;
- if agreement to proceed is not reached, formal notification from ACOA Minister to Thyssen, with negative outcome communicated to Thyssen before December 31, 1990;
- if agreement to proceed is reached, Ministers may wish to:
  - a) consider how best to address the funding shortfall identified by DND, and policy/timing concerns raised by the Defence Policy Review;
  - b) reach formal agreement by the Government to accept the concept of the Thyssen proposal, including the directed contract; and
  - c) communicate formally with the company in the affirmative, prior to December 31, 1990.

DND ANALYSIS OF THE THYSSEN PROPOSAL

1. While inadequate for all but general planning purposes due to lack of detail and narrow scope, the unsolicited Thyssen proposal for a directed, sole-source contract as contained in the paper provided to ACOA has been used as the basis for this analysis. The Thyssen proposal is for a directed contract for 250 TpZ 1 Fox vehicles, at a cost of \$290M (1990 dollars), with delivery beginning in FY 93/94. Within one year of signing such a contract, DND may, after negotiations with the company, switch the order and purchase an unspecified quantity of TH 495 vehicles for an unspecified price (see para 16).
2. In order to understand what would be required for DND to satisfy this request, it is important to understand the environment in which DND is currently operating.

THE DND ENVIRONMENT

3. The Department of National Defence (DND) is currently undergoing a "defence policy review". Due to the rapid and drastic changes in the security environment in the last several years, the policy set out in the 1987 White Paper requires change. The process for determining those changes is not yet complete.
4. Concurrent with the Defence Policy Review, we are also pursuing a major program review for determining the equipment requirements associated with the roles and missions defined by the new policy. The proposed Defence Policy and the associated capital program will not be considered by Cabinet until sometime in the new year.
5. In general terms, the new defence program, in reflecting more realistic future budget expectations, will reflect dramatic reductions in the capital program foreseen before the last two budgets. Even that reduced capital program is contingent upon government approval of major reductions in armed forces structure and supporting infrastructure. Otherwise the funding for capital will not be available and further capital program reductions will be necessary. Throughout the armed forces, there will be fewer equipments and significant rationalization of different types of similar equipments to yield the necessary savings in operations and maintenance costs.
6. This state of uncertainty affects all elements of our capital equipment program, including the equipment program for the Army. While the precise nature of DND's future army requirement is unknown pending finalization of the Defence Policy Review, DND planning is proceeding along the following lines:

ANNEX A

- a) a shift towards a lighter, more mobile, more flexible army;
- b) a rationalization of army combat vehicles that will reduce the current inefficiencies inherent in a multi-type vehicle fleet; and
- c) fuller exploitation and integration of the Militia with the regular force.

7. These considerations have led to the formulation of the Multi-Role Combat Vehicle (MRCV) project. Over the next fifteen years, the future army will require seven to eight hundred Multi-Role Combat Vehicles (MRCV), in three primary variants, to replace, augment, and rationalize existing fleets only as their useful life expires. Thus, the requirement is to procure the variants in the following order: a Reconnaissance Combat Vehicle (RCV), the Armoured Combat Vehicle (ACV), and the Infantry Combat Vehicle (ICV). The department recently agreed in principle to such a project, so it could be inserted in the long term plan. No significant funding is available prior to the mid-1990s.

IMPACT ANALYSIS AND ACTIONS REQUIRED

8. The following sections outline as best as we can, given the imprecise nature of the information available, the impact of accepting the Thyssen proposal and what DND would have to do in order to proceed with the proposal. The remainder of this section is organized according to the primary areas of impact:

- a) operational requirements;
- b) defence budget;
- c) Defence Services Program;
- d) defence industrial base; and
- e) public relations.

DND OPERATIONAL REQUIREMENTS

9. The next step is to define more clearly, over the next two years, the exact nature of the MRCV requirement. Not before then would the Minister of National Defence be in a position to demonstrate a fully-defined requirement and seek preliminary approval from Cabinet, including a procurement strategy.

10. At this time we do know that, in general terms:
  - a) the MRCV must be highly mobile;
  - b) the MRCV must provide a moderate level of protection;
  - c) a family of vehicles is the preferred concept (ie, variants with a high degree of commonality, such as the chassis, spares, communications, etc.):
    - i) Reconnaissance Combat Vehicle (RCV) to gather intelligence and to deny information to the enemy through direct fire,
    - ii) Armoured Combat Vehicle (ACV) to provide heavy direct fire support and to be part of the anti-armour capability, and
    - iii) Infantry Combat Vehicle (ICV) to provide protected transport for infantry;
  - d) the vehicle must be transportable in C-130 Hercules aircraft (weight limit of 17.97 metric tonnes and a useable width of 2.87m).
11. The Fox probably would meet mobility requirements as it is a six wheeled vehicle of proven design offering good road and track mobility with reasonable off-road movement. In addition, the Fox appears to offer a reasonable degree of protection.
12. With regard to the family of vehicles requirement, although the Fox has a number of variants, these variants do not match our other requirements:
  - a) while advertised as a nuclear, biological, chemical (NBC) reconnaissance vehicle, the Fox is not a normal recce vehicle. It is configured to hold equipment which could determine the extent of contaminated ground through ground reconnaissance and air monitoring. It would not fulfil our conventional RCV requirement, which entails penetration of enemy lines, and possibly denial by direct fire of friendly information to the enemy;
  - b) Thyssen itself acknowledges that the LUCHS is its conventional recce vehicle;

ANNEX A

- c) some modifications to other Fox variants might make it a candidate for the Armoured Combat Vehicle variant DND requires; and
- d) the Fox itself is an infantry combat vehicle, and as it currently exists, would be appropriate only for the Infantry Combat Vehicle (ICV) requirement.

Thus, the Fox is not suitable for the family of vehicles concept based on a single chassis with the particular variants DND has identified to meet the army's future needs. Several European manufacturers currently produce families of vehicles which do have our required variants, such as the Vickers Valkyr (UK), the Kraus-Maffei Puma (GER), and the Alvis Stormer (UK).

13. On the air-transportable requirement, the Fox weighs 17 metric tonnes, but with a width of 2.98m it is incapable of transport by the C-130 and therefore unsuitable for the new roles foreseen for the army. If the Fox were to be given a turret and cannon/gun to make it fit the ACV or RCV role, it would likely exceed the weight limitation of 17.97 metric tonnes. The LUCHS, the Thyssen recce vehicle, weighs 19.5 tonnes, making it too heavy to carry in a C-130.

14. To buy the Fox as the ICV first would mean that the necessary acquisition order of Recce Combat Vehicle, Armoured Combat Vehicle, and finally Infantry Combat Vehicle would be reversed. This would mean that we would be postponing replacement of those types of armoured vehicles which are nearing the end of their operationally useful and economic life (ie, the current recce and direct fire vehicles), and supplementing the existing infantry combat vehicle fleet before necessary. The vehicle requirement is based on projected future force structure; therefore, it would be difficult to absorb the Fox with existing force structures. This difficulty would be exacerbated by delivery of variants in the reverse order. The consequences of this action would be:

- a) need for increased operations and maintenance provisions (see para 22 below);
- b) need for trained personnel to operate and maintain the vehicles; and

ANNEX A

- c) if we do not proceed with the purchase of a Recce Combat Vehicle as scheduled, we would be creating a combat deficiency as our current recce vehicle, the Lynx, will be operationally deficient after 1996.

15. The army would end up with fewer vehicles than they need and could otherwise afford. They would also end up with the wrong mix of the three variants (infantry, combat, and recce combat vehicles). Thyssen proposes to provide 250 Fox infantry combat vehicles (ICV), whereas the army requirement is only 206 such vehicles. Because of the additional costs of the Thyssen proposal (see below para 24), the ICV portion would consume over 50% of the funds available for the MRCV (rather than about 14% as is now projected). Since this purchase would satisfy only the requirement for the relatively less expensive ICV, the army would only be able to afford a maximum of 550 vehicles rather than the currently planned 735. This assumes a competitive, off-the-shelf buy of an existing vehicle which would meet our requirements but would be less expensive than an improved Fox variant or fully developed TH 495. The new mix would be 250 ICVs plus 300 armoured and recce combat vehicles, rather than the 206 ICVs with 529 ACVs and RCVs.

16. TH 495. The TH 495, suggested by Thyssen as an option suitable for discussion once the directed contract is let, is a conceptual vehicle existing on paper only. It eventually might promise to satisfy all the MRCV requirements. Intended as a tracked vehicle, it would offer reasonable mobility over all terrain. Its proposed dimensions and basic weight would indicate a suitability for the C-130 Hercules aircraft. The suggested family of variants would meet the MRCV principal requirements for a reconnaissance vehicle, a direct fire armoured vehicle, and/or infantry carrier. Furthermore, it has been suggested that the TH 495 would meet current anticipated protection requirements. Given the advertised characteristics of the TH 495, it is judged that the Thyssen vehicle could enter with good prospects, subject to price, the open competition in the period of 1994-95 to satisfy the Canadian MRCV requirements.

17. The Thyssen proposal, however, would have us begin planning to acquire the Fox, and then switch plans to accommodate the TH 495. The TH 495 is still on the drawing board and the development timeline for the TH 495 is optimistic in our view. Given that quantity, price, and specifications would be subject to negotiation, such a proposal makes little sense. It would double the disruption in the MRCV project and would require that we agree to purchase an unknown quantity of unproven vehicles for an unspecified price. Clearly, we are unable to calculate costs of this part of the proposal.



Actions required to proceed with the Thyssen proposal

18. If DND were directed to purchase the Fox vehicle according to the Thyssen proposal, we would have to take the following steps with regard to operational requirements:

- a) stop the process of defining the operational requirement for the ICV portion of the MRCV project and direct the army to use the Thyssen vehicle;
- b) reverse the priorities for replacement of army combat vehicles;
- c) reconfigure existing forces to take the vehicles and examine in particular the maintenance problems associated with early delivery;
- d) review and revise the roles for the army foreseen in the current policy review to make them consistent with the limited transportability of the Thyssen vehicle; and
- e) determine the feasibility and costs of meeting the Armoured Combat Vehicle and Recce Combat Vehicle requirements from the Thyssen product line OR plan for additional costs due to inefficiencies arising from a mixed fleet of vehicles (see below).

BUDGET CONSIDERATIONS

Note: all dollar figures are 90/91 CY \$

Capital

19. Budgeted Defence Services Program project costs for the Infantry Combat Vehicle (ICV) portion of the MRCV project are currently estimated as follows:

- a) 206 vehicles at \$565K each = \$116M;
- b) \$116M times project factor of 2.5 = \$290M.

The project factor of 2.5 provides the total project cost, including the costs for the vehicle itself, project management, and integrated logistic support (initial provisioning for spares, training, technical data packages, etc.) Project factors are based on the complexity of individual projects and 2.5 is what has been estimated for the MRCV project.

ANNEX A

20. The Thyssen Fox is an expensive vehicle compared to most other potential ICV contenders. Based on confirmation from ACOA officials, the Thyssen proposal for Fox is:

- a) 250 basic vehicles (not including normal project support costs - see para 19) at \$1.16M each = \$290M;
- b) \$290M times project factor of 2.5 = \$725M.

Not only is the Thyssen unit price almost twice as much, but Thyssen is proposing to supply 44 vehicles more than our requirement of 206 ICVs.

21. The increase in the total Infantry Combat Vehicle project cost that would be created by a directed buy of Fox is quite significant as detailed hereunder:

- Thyssen proposal:	\$725M
- Budgeted costs for competed ICV portion of MRCV	\$290M
Increase	\$435M

Operations and Maintenance

22. Since these vehicles would be introduced to the current fleet nine years earlier than currently planned, and there is no corresponding retirement or reduction of other vehicles scheduled, some provision must be made to cover the unforecasted operating and maintenance costs. The least disruptive option for army operations is additional money. Based on a comparable project, we estimate that this buy would add another \$14.5M a year for 9 years or \$130M, before inflation, to the Operations and Maintenance (O & M) budget. An alternative would be to place the newly purchased Fox in storage. Another possibility would be to put other vehicles, such as trucks or the current M 113 fleet into storage. Both would be disruptive of ongoing army activity.

Inefficiencies

23. Financial expenses from the lost opportunity for economies of scale when several hundred vehicles are purchased in two or more separate buys (by increased per unit costs, inefficiencies in the purchase of spares, in stocking, storage, contracting and other such areas) could run to at least 10% of the MRCV project's cost (current estimate \$2,100 million) or an additional \$200M.

Summary of Costs

24. In summary, the additional costs of the Thyssen proposal, over and above those already budgeted for the ICV portion of the MRCV project, would include:

- a) \$435M in capital for the Infantry Combat Vehicle project;
- b) \$130M in unforecasted O & M for the additional vehicles; and
- c) \$200M for inefficiencies and lack of fleet rationalization;
- d) for a total of \$765M.

With the already scheduled \$290M for the ICV portion, the new total ICV cost under the Thyssen proposal would be \$1.1B.

Actions required to proceed with the Thyssen proposal

25. In order to proceed with the Thyssen proposal, all of the required funding has to be included in the defence budget in the appropriate years. This involves:

- a) bringing forward the originally scheduled costs of the ICV portion of the MRCV project of \$290M from 2001/02 - 2005/06 to the 1993/94 - 1997/98 period;
- b) finding a source for the additional \$435M in capital for project costs over the period 1993/94 to 1997/98 (para 21 above);
- c) finding a source for the additional \$130M in operations and maintenance funding over the period 1994/95 to 2003/04 (para 22 above); and
- d) absorbing the \$200M in inefficiencies over the life of the project (para 23 above).

ANNEX A

26. Over the proposed Thyssen delivery period of 1993/94 to 1995/96, the Defence Services Program (DSP) contains only \$70M in funding for the entire MRCV program. Acceptance of the Thyssen proposal would thus require an additional \$480M in capital over this time frame, together with an additional \$175M over the subsequent two years to cover the remaining costs for integrated logistics support. This is a total of \$655M (the total ICV project cost under the Thyssen proposal of \$725M as described in para 20, minus the \$70M already allocated for the MRCV project).

27. In the absence of new funding, the impact on the capital program of having to absorb an additional \$480M over the delivery period (93/94 - 95/96) would be enormous. This is particularly true since these are years in which DND already has severe cash flow problems. The entire army capital program for this period totals \$1.4B for 51 projects addressing the replacement of obsolete equipments. The additional funds required equate to more than one-third of programmed funds, and for only one part of one project.

IMPACT ON THE DEFENCE SERVICES PROGRAM (DSP)

28. The Thyssen proposal to begin delivery by FY 93/94 would call for cash which is not available from within the current Capital Program plan. If the additional \$655M were not to be provided to DND, there would have to be massive displacement of well developed and higher priority programs.

29. Large army projects in this period are the Tactical Command and Control Communication Systems (TCCCS), the Northern Terrain Vehicle (NTV), the Utility Tactical Transport Helicopters, the Light Support Vehicle Wheeled, and plans to increase Reserve equipment and infrastructure.

30. TCCCS addresses the highest current army priority - new radios and communications. The winning proposal was recently approved by Cabinet but is unaffordable within the DND capital funding allocation for this project. We are currently reviewing the size of the requirement, negotiating with the contractor, and trying to find other projects which can be reduced to make TCCCS affordable.

31. Northern Terrain Vehicles are in the definition stage, and affordability will be addressed in early 1991 when this stage is completed.

ANNEX A

32. It is, therefore, impossible to absorb the cost of the Thyssen proposal without creating capability gaps or deleting combat functions vital to general purpose land forces. Without outright cancellation of TCCCS as now defined, or NTV, plus deferrals/cancellations of other projects, DND could not proceed with the Thyssen proposal within funds currently budgeted for army equipment. Furthermore, projects in advanced stages in other environments--such as the Naval Reserve vessels, the New Shipborne Aircraft (NSA), new Search and Rescue Helicopters, support to the RCMP--would have to be adjusted as well. At the very least, some of these projects would have to be delayed, creating more combat deficiencies.

33. As many of the advanced projects are replacements for aging equipment, delaying implementation involves additional costs associated with life extension until such time as the equipment can be replaced. The continuation and expansion of O & M expenditure required for the maintenance of obsolete equipment cannot be estimated accurately, but could be on the order of hundreds of millions of dollars. For example, the relatively inexpensive 5/4 tonne truck (LSVW, Light Support Vehicle Wheeled) is currently being operated seven years past the end of its scheduled life; the O & M is in excess of \$30M per year. These additional expenditures would then create a ripple effect, displacing other projects further down the line.

Actions Required to Proceed with the Thyssen Proposal

34. To implement the Thyssen proposal would require the following actions with regard to the Defence Services Program:

- a) cancel, downsize, or defer TCCCS (as currently planned), NTV, as well as other army projects;
- b) cancel, downsize, or defer projects in other environments, including the New Shipborne Aircraft, the Naval Reserve vessels and the Search and Rescue Helicopters;
- c) chart out second and third order effects and make additional adjustments in the O & M and capital programs; and
- d) revise roles and missions to take account of the combat deficiencies created by the DSP dislocations.

DEFENCE INDUSTRIAL BASE

35. A new military vehicle facility would exacerbate the existing, widely documented overcapacity in the sector, leading to any of the following impacts strictly from a DND point of view:

- a) increased demands on government from other suppliers for similar directed contracts and/or subsidies in the wake of lack of work; this could further distort our planned acquisitions;
- b) chronic layoffs and dislocation of sector personnel, leading to increased demands for government assistance; and
- c) relocation out of the country of existing and proven facilities, potentially disrupting our supply lines for existing vehicles and spares; and
- d) intensive competition which could lead to deliberate underbidding, with resultant contract difficulties and cost overruns and demands for government assistance.

36. Defence industry would also be impacted in other sectors as the cancellations, downsizing, and deferrals of other projects occurred to make room for the additional costs and earlier funding of army combat vehicles. Many companies anticipating new contracts, after much definition work and expense, would be impacted in the electronics, aircraft, and shipbuilding sectors.

Actions required to proceed with the Thyssen proposal

37. To adjust to the effect of proceeding with the Thyssen proposal on the defence industrial base, we would have to:

- a) cancel or defer plans for affected projects;
- b) develop a sector rationalization policy and plan with Industry, Science, and Technology Canada, Department of Supply and Services, Atlantic Canada Opportunities Agency, and Western Diversification, including associated money to handle the various industry demands and needs;
- c) continue to monitor and adjust the DSP for follow-on disruptions.

ANNEX A

IMPLICATIONS FOR PUBLIC RELATIONS VIB-A-VIS DND

38. Recent events such as the situation at Oka and the crisis in the Persian Gulf have created a reasonably positive environment for DND and the Forces. Maintaining it in light of major defence reductions which will be embodied in the new policy review will be a challenge. This directed procurement would create a strong negative public reaction based on:

- a) distorting the army program against a background of significant reductions in army structure in the new policy;
- b) increased costs of this project against a background of financial restraint;
- c) the impact on industrial overcapacity in the military vehicles sector; and
- d) the departure from the normal competitive process.

Action Required to Proceed with the Thyssen Proposal:

39. In order to counter the negative publicity, we would have to develop a defensive communications plan.

SUMMARY

40. In general, based on our knowledge to date, if DND were to be instructed to proceed with this proposal, the Department and the army would face a daunting task to fit the Fox into the MRCV project. DND's budget does not allow the increased costs to be taken from existing reference levels. In short, our points are as follows:

- a) the timing is inappropriate as DND is in the midst of a policy review which will change the structure and the roles of our army;
- b) DND would only be able to afford 550 of the 735 vehicles required, and with the wrong mix among the infantry, combat, and recce variants;
- c) since Fox does not fit our operational requirements, we would have to reverse priorities for replacement of army vehicles resulting in further review and revision of army roles and structure, combat deficiencies, and unscheduled operations and maintenance costs;

ANNEX A

- d) once integrated logistics support, training, infrastructure, etc are considered, a contract price of \$290M translates into a project cost of \$725M, with an additional \$130M in operations and maintenance;
- e) once factored into the Defence Services Program, the amount of unavailable capital is \$655M in the 93/94 - 97/98 period, with an additional \$130M in O & M over the next decade;
- f) this money is not available in DND's existing reference levels without major dislocations of the Defence Services Program (ie, deferment, cancellation, or downsizing of such projects as TCCCS and/or Northern Terrain Vehicle; and
- g) exacerbation of existing overcapacity in the defence industrial base.



THE COMPANY

Thyssen Industrie AG, based in Germany, is one of the world's largest industrial manufacturing companies with sales exceeding \$25 billion, and 136,000 employees world wide.

In Canada, Thyssen's holdings include:

- Budd Canada Inc., Kitchener (automobile parts);
- Northern Elevator Holdings Ltd., Toronto (elevators);
- Greening Donald Co. Ltd., Hamilton (metal fabrication);
- Thyssen Marathon Canada Ltd., Mississauga (steel importers);
- and
- Thyssen Canada Ltd., Rexdale (steel materials trading).

In all, Thyssen employs some 2,500 Canadians.

Thyssen's defence operations are centred in a subsidiary, Thyssen Henschel, annual revenues \$688 million, located in Kassel, Germany. From this facility, Thyssen produces a wide range of world-class armoured and military vehicles for use by NATO forces.

THYSSEN'S ESTIMATES OF FORECAST REVENUES FOR BHI  
(\$Millions 1990)

Expected Vehicle	Revenues							Total Market Revenue	Estimated Probability of Winning	Total Revenue
	93/94	94/95	95/96	96/97	97/98	98/99	99/00			
TPZ Fox Canada	34.8	127.6	127.6	-	-	-	-	\$290	Directed	\$290
TPZ Fox U.S. (NBC)	10	10	10	10	10			\$ 50	90%	\$ 45
U.S. National Guard	10	25	50	50	50	50		\$235	50%	\$118
ASV	750	8	16	30	30	30	30	\$114	40%	\$ 46
U.S. Air Force EOD + Others	200	9	9	9	9	9	9	\$ 45	35%	\$ 16
Armoured Gun System	120	67	133	200				\$400	40%	\$160
Europe (Norway/Germany)	1200	40	60	60	60	60	60	\$280	55%	\$154
Environment: Canada and U.S. (flue gas scrubber revenues only)		24	32	55	44	45	35	\$235 <sup>1</sup>		\$ 235
Total										\$1064

<sup>1</sup> Already discounted.

Thyssen's FGD wet-limestone treatment, which captures SO<sub>2</sub> emissions from coal-fired power stations, is leading-edge, and is currently in use in some 40 stations internationally. (More details on environmental markets are outlined in Annex C.)

- In the future:

.. Based on market assessments, Thyssen will consider transferring "organic composting" technology for the treatment of municipal solid waste. Thyssen does not yet have firm market estimates in this area. The company is, however, pursuing contracts to address municipal waste treatment in Vancouver, Edmonton, Halifax, and Toronto. (Other products include airport loading bridges, material handling, specially mixers and machinery.)

EMPLOYMENT PROJECTIONS

	<u>1991/92</u>	<u>1992/93</u>	<u>1993/94</u>	<u>1994/95</u>	<u>1995/96</u>	<u>1996/97</u>	<u>1997/98</u>	<u>1998/99</u>	<u>1999/00</u>
Construction and Maintenance	50	200	100	50	50	30	30	30	30
Environmental	-	-	-	81	144	136	99	129	129
Defence	15	100	198	379	800	520	648	430	257
<b>Total</b>	<b>65</b>	<b>300</b>	<b>298</b>	<b>510</b>	<b>994</b>	<b>686</b>	<b>777</b>	<b>589</b>	<b>416</b>





Ottawa Office  
4th Floor  
60 Queen Street  
P.O. Box 1667  
Postal Station "B"  
Ottawa, Ontario  
K1P 5R5

Bureau d'Ottawa  
4<sup>e</sup> étage  
60, rue Queen  
Caser postal 1667  
Succursale "B"  
Ottawa (Ontario)  
K1P 5R5

SECRET ADVICE TO THE MINISTER

MEMORANDUM

DEC 10 1990

TO: The Honourable Elmer MacKay

FROM: Peter R. Smith  
Vice-President  
ACOA-Ottawa

SUBJECT: Thyssen Proposal - Bear Head Industries

Following our several telephone conversations last week, an interdepartmental meeting was called Friday, December 7, 1990, to officially consider all of the various positions/opinions respecting the above noted proposal in order to prepare a comprehensive position paper for discussion.

Representatives of Privy Council Office, External Affairs, Supply & Services, National Defence, ISTC, Treasury Board and Finance attended. The meeting was chaired by ACOA.

Copies of the latest draft of the ACOA authored Aide Memoire were distributed to each in attendance as well as a DND position paper, which was received just prior to the meeting. External Affairs tabled their latest position on the subject, then each of the participants were given an opportunity to speak to their respective positions.

As the Thyssen initiative had been in existence for several years and since each of the participants had varying degrees of involvement over the years, I considered that one of the advantages of having this session was that each could through this exercise, have the benefit of a detailed overview of all of the most recent available facts surrounding this updated proposal.

.../

Canada

000229

Attached you will find as comprehensive an Aide-Memoire as is currently possible, representing the disparate views of all concerned, which can now be used as a background paper for you and your colleagues to discuss. We have attempted to format it in such a way as to minimize the necessity for change, should there be a decision to refer this matter to Cabinet.

In short all of the participants expressed serious reservations about pursuing this initiative at this time and the following is an attempt to capture the various degrees of concern.

The Department of National Defence is categorically not in favour of the proposal. Their views are based on operational considerations, financial implications, timing, impact on the defence policy, which as yet is unannounced and the negative impact such a decision would have, not only on the defence industrial base, but also on the communications aspects of the inconsistencies in taking such a decision in relation to other initiatives already approved or about to be approved.

External Affairs have serious reservations about the company's marketing plans and the potential impact the establishment of such a plant based on a sole source order may have on the continuing discussions Canada is having with the United States on the various elements of our defence economic relationship. Admitting that more information would be required, they also expressed reservations about the impact as well on the proposal to produce environmental products with respect to the competition with existing Canadian capacity.

Department of Industry Science and Technology expressed concern that proceeding in this manner goes contrary to Canada's industrial policy and industrial benefits policy and felt awkward about commenting substantively on the proposal since they did not have an opportunity to review the company's business plan in detail.

Finance, Treasury Board and Supply & Services Officials basically felt that if the business plan was made available and could withstand the scrutiny that similar initiatives must undergo, they would have little trouble supporting the proposal, as long as the above noted concerns were satisfactorily addressed and a Cabinet decision was forthcoming.

In short, the views of all departments over the years have not changed, but due to the economic climate and other factors, opposition to the initiative has definitely widened, has

.../

000230

solidified and has become even more legitimate. Notwithstanding this opposition, each department also offered suggestions as to what would have to be done to allow this proposal to proceed.

Without exception, each of the participants, most notably DND who would have to fund the vehicles, DIST who have a mandate for analyzing the impact on the industrial infrastructure in this country and Finance made an appeal to have the company's business plan exposed prior to being able to adequately comment on the viability of the proposal. Even assuming that the company would disclose in more detail their marketing and business plan, DND felt that proceeding at this time would result in the cancellation, downsizing or even deferring of existing and proposed projects such as TCCCS, NTV, NSA and Naval Reserve Vessels, as well as having to revise roles and missions to account for combat deficiencies created by this proposal. A case was also made that such a decision would increase the demands for similar decisions in future, thus eroding any possibility of future competitive processes, creating chronic layoffs and relocation of existing proven facilities. Finally such a proposal if pursued would create a tremendous communications challenge, fraught with inconsistencies which could prove to be most embarrassing to both the Department and the Government in times of restraint.

Although I have only become personally acquainted with this file over the past six months, I have now had ample time to analyze the difficulties associated with approving such a proposal in the past. Some of these concerns could have at the time been either eliminated or at best minimized, based on Thyssen's reputation and the potential benefit to Atlantic Canada. However, as I analyze the facts now, in light of all of the factors that must be considered such as our current economic situation, the Defence Agreement with the US, the state of the National Defence budget and the unapproved Defence policy, I would be less than responsible, despite the potential positive impact on Atlantic Canada, to advise that this initiative should be pursued. To proceed on this basis during such a period of restraint and with such unanimous opposition for what I now consider to be valid concerns would just result in an indefensible position to justify.

Having said this however, the attached report is being tabled for your consideration and further discussion. I am available at your convenience to review any aspect of this report or to discuss further why I have arrived at the above conclusion with respect to the disposition of this file.

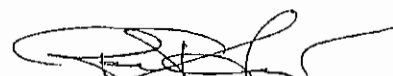
  
Peter R. Smith

000231







Min. Wilson	6
Min. McDermid	2
F.W. Gorbet	3
M. Caron	2
D. Dodge	1
E.L. Bennett	1
K. Norrie	1
J.R.M. Anderson	1
General Director	1
ADMO	1
Director	1
C.R.	2
D.D./S.D.	1
Pending Officer	1

Security classification / Classification de sécurité

**SECRET**

Director / Telephone number / Numéro de téléphone / 996-081

Our file / Notre référence / EDD-4095-03-6

You file / Votre référence

Date / December 10, 1990

TO: The Minister

CONFIDENCE OF THE QUEEN'S  
PRIVY COUNCIL  
DOCUMENT CONFIDENTIEL DU  
CONSEIL PRIVÉ DE LA REINE

FROM: Frederick Gorbet

SUBJECT / OBJET

THYSSEN/BEARHEAD: PROPOSED FACILITY IN NOVA SCOTIA

For Consideration By Operations Committee  
Week of December 10, 1990

1. PCO indicates that the Thyssen proposal is not on the agenda for the Tuesday meeting of Operations Committee. Nonetheless, Mr. MacKay may wish to raise the issue for discussion on Tuesday or Thursday.
2. We are attaching a draft TBS memo and would endorse the position expressed by Board officials against the Thyssen proposal.
3. We have also indicated to ACOA that the Finance position presented in the Thyssen document should convey our concern that a directed contract would impose an additional layer of constraint on DND which is already examining its program under the assumption of no real growth in funding. We have also stated our objection to a directed contract as a condition for the establishment of the facility, which should be assessed on commercial merits, irrespective of directed procurement.
4. You will recall that you did not wish to bring this matter to Mr. Mazankowski's direct attention in your recent letter regarding possible items for Operations Committee during your absence.





MINISTER  
Ottawa, Ontario K1A 0A6

MINISTRE

DEC 11 1990

SECRET

The Right Honourable Brian Mulroney  
Prime Minister of Canada  
Langevin Building  
80 Wellington Street  
Ottawa, Ontario  
K1A 0A3

My Dear Prime Minister:

I am writing to seek your support for the proposal by Thyssen to establish an armoured-vehicle and, environmental-industries manufacturing facility in Nova Scotia.

As you know, after a period of some five years, the company is understandably anxious for the Government of Canada to reach agreement on their proposal, and I fully appreciate your interest in responding to the company prior to your visit to Germany scheduled for this January.

To revisit very briefly the status of the proposal, the company has indicated formally to the Government through ACOA, that it will establish a very significant (\$61 million) manufacturing facility in Nova Scotia, should DND purchase either 250 of its "Fox" vehicles for \$290 million (\$ 1990), or 207 of its next generation "TH 495" multi-role combat vehicles. (For your consideration, please find attached the first page of the Thyssen Aide Memoire which summarizes the company's proposal.)

As you may know, DND has assessed the proposal most thoroughly, and has concluded that the proposed purchase of the next-generation TH 495 vehicle could meet DND operational requirements (subject to price), but that if directed to purchase Fox vehicles, DND would have very significant problems -- particularly relating to funding -- to accommodate a mixed fleet, earlier than planned delivery, and so on.

.../2

Canada

000288

While I, of course, respect the expert views of DND officials, I nevertheless share your concern that we not lose this excellent opportunity, through Thyssen, to attract to Canada world-class technology, and follow-on exports, and to reaffirm industrial ties to Germany, a country certain to fuel European, both east and west, economic growth into the next century.

Accordingly, after a series of last-minute negotiations with Thyssen, the company has agreed to address concerns raised by DND and others, by restructuring their proposal in a way in which I am hopeful can allow the initiative to be achieved. (I have attached a copy of their formal letter, outlining their commitments.)

Specifically, the company will offer DND 207 of its TH 495 vehicles, under the original funding envelop of \$290 million, with delivery to commence in 1994. By their own estimates, should it be accepted by the Government, this solution would immediately result in a savings to DND of some \$330 million in lower maintenance and other costs beyond the funding required to accept the Fox vehicle, and, at the same time, maximize the department's flexibility to plan its defence policy. In addition, Thyssen has worked, and will continue to work, most closely with the military on the development of this vehicle to ensure, unlike the existing Fox vehicle, that this next-generation fully meets Canada's operational needs. Finally, while the TH 495, as an vehicle under development, has not yet had time to be adopted by NATO forces as has the Fox, the TH 495 is being designed by Thyssen as the international peace-keeping vehicle, and can be marketed abroad accordingly, fully in keeping with Canada's export policy, and international reputation and principles.

Moreover, such a directed contract would, in my view, be fully in keeping with our Government's commitment, articulated in the Speech from the Throne two years ago, to ensuring, providing that operational requirements are met, that procurement promotes lasting regional economic development.

.../3

000289

Indeed, in this latter regard, and to support the activities of DND, I would be prepared, should the Thyssen proposal be accepted, and subject, of course, to the views of our colleague, the Honourable Michael Wilson, to allocate to DND the lion's share of ACOA's lapsing funds over the near and medium terms to allow DND to meet their obligations.

To summarize, I believe the decision facing the Government and DND is whether, on a directed contract basis, to purchase the Thyssen Fox vehicles; alternatively, whether to loose this excellent and unique opportunity; or lastly, whether DND -- with supplementary funding -- wishes to acquire a leading-edge peace-keeping vehicle, which DND will help design, produced by an excellent company, a vehicle which will support Canada's international and other obligations.

To conclude, Prime Minister, if you concur, it would be my intention on Thursday, December 13, to have the entire proposal, including the company's final offer, brought forward for discussion by Operations Ministers. Should we reach agreement, I would hope that a more formal decision could be reached by Cabinet later that morning, so that a formal communiqué could be issued from the Government to the company prior to year end.

Sincerely,

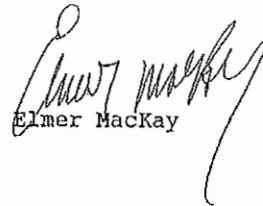

Elmer MacKay

Attachments

c.c. The Honourable W. McKnight

000290



*Emf desrosiers*

L1104-1

A1104-1

Room 509  
Confederation Building  
House of Commons  
Ottawa, Ontario  
Canada K1A 0A6

Pièce 509  
Édifice de la Confédération  
Chambre des communes  
Ottawa (Ontario)  
Canada K1A 0A6

DEC 19 1990

SECRET

Mr. Norman Spector  
Chief of Staff to the  
Prime Minister  
Room 231, Langevin Block  
80 Wellington Street  
Ottawa, Ontario  
K1A 0A2

Dear Norman:

Last week, I received your personal assurances that the Thyssen issue would be considered imminently via an "alternative route", rather than being discussed at Operations as I and others had wished.

While the direction from your office has been uncertain, I am under the impression that our next steps in resolving the Thyssen issue include discussions between the Prime Minister and Michael Wilson on funding.

If DND purchases Thyssen's next-generation vehicle, under a directed contract of \$290 million, this would involve, by DND's own generous estimates, program funding of \$725 million (\$1990), not \$1 billion plus. Moreover, in light of the lasting and unique development for Nova Scotia to be gained, I am, as you know, fully prepared to use ACOA's lapsing funding to contribute to sourcing.

On timing, I would simply remind you that Thyssen - which has waited for five years, and was invited by our Government to locate in Canada - seeks a decision by year end. Moreover, I (as I'm sure you) would be most pleased if the Prime Minister was in a position to pronounce favourably on the Thyssen proposal during his visit to Germany next month.

I remain hopeful that you and others can shortly bring the Thyssen issue forward for discussion by Ministers, in order to meet the wishes of the company and our Government.

Yours sincerely,

Canada

*Emf*  
Elmer MacKay

MINISTER'S OFFICE  
A. C. O. A.

DEC 21 1990

3700-6-1  
BUREAU DU MINISTR.  
A. P. E. C. A.

ACOASCH\_INQ.NB\_HO\_THY.06.0005.00  
05

1 of 2

000317





\* 10 Jan

ACOA has sent a letter dated 9 Jan to  
Pomeroy (A/Sec 100), copy to [redacted] saying a  
couple of points in an updated paper. Expect it!

Ed--

John  
John out of town till Monday.  
His sec. has updated this paper.  
We have to get a copy. John knows then  
Pomeroy asked for him to call me on  
Monday and date me!  
J. has called  
10 Jan

telecon with McDowell 9 Jan 91

1. He's not sure what is happening. Before Christmas, E. Mackay wrote to PM saying, "I think we should do this, don't you?", and to Spector saying, "I leave this in your capable hands." Nothing since.
2. PM's trip to Germany is still on (regular trip), but no meetings with Thyssen are on agenda and he's not been asked to write any notes.
3. PCO has delivered our recommended changes in the "joint" portion and new analysis to ACOA. John will make the recommended changes and send us new copy.
4. His secretary Isabell phoned Claire to ask for a copy of our new analysis on disk. I see no problem with this as we provided the old version on disk. It is on the attached disk, the only file. WE NEED TO GET PREVIOUS AS WELL AS THIS DISK BACK--we can't order anymore and Claire is out!! Guess you should arrange with John on how to get disc to him.



CLERK OF THE PRIVY COUNCIL AND  
SECRETARY TO THE CABINET



GREFFIER DU CONSEIL PRIVÉ ET  
SECRÉTAIRE DU CABINET

CANADA

SECRET

Jan 11 6 1991

MEMORANDUM FOR MR. NORMAN SPECTOR

Thyssen/Bear Head Industries

You will find attached, for information, a revised copy of the joint ACOA/DND Aide Memoire on the Thyssen proposal. It now reflects DND's preliminary analysis of the costs of Thyssen supplying DND with the TH 495 vehicle rather than the TPZ Fox.

Background

On December 10, 1990, we submitted to you an Aide Memoire on Thyssen, prepared jointly by ACOA and DND as requested at your November meeting with Ministers MacKay and McKnight.

On December 11, 1990, Thyssen submitted to ACOA a more specific proposal to allow DND at some later date to substitute a lower number, possibly 207, of the TH 495 vehicle (still on the drawing board) for the original proposal for 250 of the TPZ Fox vehicles at the same contract price of \$290 million. Although ACOA revised some of its portion of the Aide Memoire immediately (reflected in a December 12, 1990 version), DND has just provided its input and this is now incorporated in the attached document dated January 10, 1991.

Comment

The DND amendments in summary argue that the substitution of the TH 495 for the Fox makes no difference to the total cost of the acquisition (\$1.1 billion versus \$290 million budgeted). Although ACOA is of the view that this is overstated (see the attached correspondence), the bottom line is that the Thyssen proposal costs at least \$500 million (in ball park terms) more than was budgeted.

The bottom line from our perspective continues to be that this project is undesirable since it would involve DND acquiring a product that does not meet its requirements; in quantities larger than it requires; at a price higher than it can afford; in a time frame in advance of its needs, and for which a source of funds has not been identified. In addition, the longterm viability of the Thyssen plant in Nova Scotia appears questionable. Although the DND analysis of its needs appears based on facts, the ACOA analysis appears to have accepted the Thyssen proposal at face value, and in many areas, uses optimistic assumptions.

*orig signed by*

Paul M. Tellier

Attachments

MacGillivray/Rowat/eyd

111070  
DRAFT

SECRET

**AIDE MEMOIRE  
BEAR HEAD INDUSTRIES (THYSSEN)**

**ISSUE:**

Whether to support the proposal by Bear Head Industries Limited (a wholly owned subsidiary of Thyssen Industrie AG) to establish a heavy manufacturing facility in Nova Scotia, based on a Canadian Government directed contract for 250 military vehicles for the Department of National Defence (DND).

**BACKGROUND:**

Thyssen Industrie AG, based in Germany, is one of the world's largest industrial manufacturing companies. In Canada, Thyssen Industrie AG employs approximately 2,500 at holdings that include:

- Budd Canada Inc., Kitchener Ont. (automotive parts);
- Northern Elevator Holdings Ltd., Toronto Ont. (elevators);
- Greening Donald Co. Ltd., Hamilton Ont. (metal fabrication);
- Thyssen Marathon Canada Ltd., Mississauga Ont. (steel importers).

Thyssen Industrie AG first declared interest in establishing a facility in Cape Breton in the mid-1980's.

In 1988, an Understanding in Principle (UIP) was signed between Bear Head Industries Ltd. and the Government of Canada, as represented by the Ministers responsible for the Atlantic Canada Opportunities Agency (ACOA), DND and the Department of Regional Industrial Expansion (DRIE). This UIP established that the company would be considered for participation in upcoming military vehicle procurements, and be considered for assistance under a number of funding mechanisms including federal-provincial infrastructure assistance, the Cape Breton Investment Tax Credit (CBITC) and, at a later stage, the Defence Industry Productivity Program. The financial details were to be worked out in reference to a business plan for military vehicle and commercial projects, to be provided later.

To date, Bear Head Industries has not put forward an acceptable business plan. This has made it impossible to assess its CBITC application which asks for consideration of a \$98 million investment.

At this time, the Bear Head Industries application is the only outstanding application under the CBITC program. As all expenditures must be made prior to December 31, 1992, it would seem unlikely that Bear Head will be in a position to benefit from the program.

In late 1990, a formal proposal based on a directed procurement to Bear Head Industries of light armoured vehicles was put forward under ACOA sponsorship. Discussions at the working level did not lead to the presentation of the proposal to Ministers.

The proposed procurement would be part of the Multirole Combat Vehicle Program (MRCV), which has been identified by DND, but is unfunded, and has no statement of operational requirement or affordability at this time. Project implementation is expected in 1996.

The Bear Head Industries proposal suggests the following benefits would flow from the project:

DRAFT

SECRET

- 2 -

- Creation of 600 direct jobs in a particularly depressed region;
- Development of a world class manufacturing base, supported by the diversified global infrastructure and financial base of one of the world's largest heavy manufacturers;
- Transfer of production technology in defence and environmental products, and production mandates;
- Provision of a high quality product to DND which meets its needs at a reasonable cost.

However, Bear Head Industries has not demonstrated the long term viability of the project, or developed an appropriate business plan. Plans for commercial product lines have not been adequately explored. This is particularly disturbing in light of declining global defence markets.

Canada currently has three major existing military vehicle producers competing for limited DND business, which is insufficient to sustain them (i.e. General Motors Diesel Division in London, Ontario, UTDC (Lavalin) in Kingston, Ontario and Bombardier Inc. in Valcourt, Quebec). In addition there are a number of specialty vehicle manufacturers, operating in niche markets. This situation, coupled with declining overall demand has led Industry Science and Technology Canada (ISTC) to an investment strategy for the sector which does not support greenfield investment. In view of the above, the federal government should not be supporting financially the establishment of another military producer in Canada.

Internationally, Bear Head Industries would be in direct competition with General Motors Diesel Division (DDGM), which produces Light Armoured Vehicles in London Ontario, for Canada, the U.S. and other countries. DDGM employs up to 700, and has received approximately \$40 million in federal assistance, largely in the form of repayable contributions.

The appropriateness of a directed contract for 250 military vehicles has been reviewed by DND and the Thyssen proposal has been found to be unacceptable. Neither the vehicle proposed by Thyssen nor the timing of a proposed purchase meet DND's need at this time; it is not acceptable operationally, is unaffordable, and would impact adversely and severely on the ongoing defence policy review, and on other higher priority projects.

RECOMMENDED POSITION:

In view of the above considerations, it is recommended that the Bear Head Industries Ltd. proposal to establish a facility in response to a directed procurement not be supported. The company should be advised that the Cape Breton Investment Tax Credit file will be closed and that DND does not intend to proceed with the Multirole Combat Vehicle Program until 1996.

INTERDEPARTMENTAL CONSULTATIONS:

This document has been prepared in consultation with the Departments of Industry Science and Technology, National Defence and Finance. All three organizations fully support the recommended course of action.





cc: RB/  
J.B.  
A.G.  
A Mac G

Ottawa Office  
4th Floor  
60 Queen Street  
P.O. Box 1667  
Postal Station "B"  
Ottawa, Ontario  
K1P 5R5

Bureau d'Ottawa  
4<sup>e</sup> étage  
60, rue Queen  
Caser postal 1667  
Succursale "B"  
Ottawa (Ontario)  
K1P 5R5

January 9, 1991

Mr. William Rowat  
Assistant Secretary to the Cabinet  
(Economic Policy Committee)  
85 Sparks Street  
Room 506, Blackburn Building  
Ottawa, Ontario  
K1A 0A3

Dear Mr. Rowat:

38056

I am writing to express concern on the Thyssen/  
Bear Head Industries issue, regarding the January 9, 1991,  
version of the aide mémoire, and in particular, DND's  
assessment of the costs associated with the company's next  
generation TH 495 vehicle.

While not wishing to challenge the expert advice  
being submitted to the Government by DND officials, I  
believe it important to draw attention to an apparent  
internal inconsistency in the DND analysis, which could  
result in a significant overestimate of the financial  
costs to the Government of effecting the directed contract  
sought by Thyssen.

As you may recall, it has consistently been the  
position of Thyssen that the new generation TH 495 vehicle  
-- under development -- would be designed and built in  
close collaboration with DND military experts, in order to  
ensure that DND's operational requirements are achieved.

The DND analysis (para 16) notes the advertised  
characteristics of the TH 495 vehicle could satisfy the  
potential operational requirements of the various groups  
of armoured vehicles proposed to be acquired by DND under  
the Multirole Combat Vehicle (MRCV) project.

However, when the TH 495 directed contract is  
costed by DND, the costing methodology assumes (paras 25-  
29, and 45c) that the vehicle (like the older Thyssen Fox  
vehicle) will only meet the infantry combat vehicle  
variant, thereby requiring DND to expend considerable  
additional funds (estimated by DND at \$115 million, and  
\$200 million respectively, for increased O&M and

inefficiencies). Under this assumption, these potential costs would be incurred because the order of the vehicle purchases would have to be juggled by DND, and because the degree of fleet interoperabilities would suffer.

However, if the TH 495 vehicle potentially meets the operational requirements (known to date) of the entire range of vehicles to be purchased under MRCV project, then DND would not have to juggle its purchases, and the worries over fleet inoperability subside -- thereby reducing overall project costs, by DND's own estimates, by some \$300 million.

Accordingly, should our interpretation of this inconsistency prove correct, the TH 495 directed contract would indeed present a preferred option to the Government (over the Thyssen Fox directed contract), because it would in principle meet the needs of the military at a cost estimated by DND at approximately \$770 million, rather than the \$1,055 million estimated costs of acquiring the Thyssen Fox vehicle.

I trust that this letter will accompany the package of materials to be submitted by your staff to the Prime Minister's Office.

Yours sincerely,

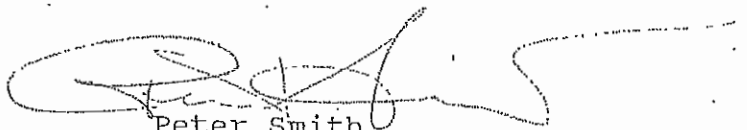
  
Peter Smith  
Vice-President

c.c. Rob Gillespie



SECRET

National Defence	Défense nationale
Assistant Deputy Minister (Materiel)	Sous-ministre adjoint (Matériels)
National Defence Headquarters Ottawa, Canada K1A 0K2	Quartier général de la Défense nationale Ottawa, Canada K1A 0K2

28 January 1991

Mr. William Rowat  
 Assistant Secretary to the Cabinet  
 (Economic Policy Committee)  
 85 Sparks Street  
 Room 506, Blackburn Building  
 Ottawa, Ontario  
 K1A 0A3

ACOA / APECA	OTTAWA
RECEIVED / REÇU	FEB 14 1991
CORRESP # 000550	OK
FILE / DOSSIER #	2635-72

Dear Mr. Rowat:

I apologize for the delay in providing you comments on Mr. Peter Smith's letter of January 9, 1991 relating to the Thyssen/Bear Head Industries issue, in which he draws your attention to what he perceives to be an inconsistency in DND's evaluation of the Thyssen proposal relating to the developmental TH 495 vehicle. I also apologize for having to burden you with a resolution of technical matters in this fashion, but in the circumstances it appears to be the only way to deal with this issue.

The initial Thyssen proposal was based on the Fox, an Infantry Combat Vehicle (ICV), and our analysis focused on the Fox vehicle. Mention of the TH 495 in that proposal was cursory, i.e. DND had an option, once a directed contract for Fox was signed, to purchase an unspecified number of vehicles for an unspecified price.

On December 12, 1990, we were advised by letter from Mr. Smith of Thyssen's latest proposal of a fixed price for a set number of unspecified types of TH 495 vehicles. The precise wording used in ACOA's amended page one, attached to Mr. Smith's letter, was as follows "...within 12 months of signing the contract for the TPZ Fox vehicles, the company is prepared to allow DND to switch its order for the Fox and purchase instead 207 of Thyssen's next-generation TH 495 vehicles for the same total price of \$290 million". In our view, the implication throughout is that we are speaking of the ICV variant. That assumption is particularly valid since, when speaking of variants of a family of combat vehicles, the ICV is well-recognized as the fundamental or basic variant, with all other variants seen to be more complex, more expensive, and certainly requiring a longer design phase.

.../2

Canada

SECRET

RCMP.SCH\_INQ.HQ.STXT.34.0020

000336

2 of 4

For purposes of our subsequent analysis, therefore, we assumed the Thyssen 495 fixed-price proposal to relate to the ICV. We accepted that since the TH 495 was a conceptual vehicle further variants i.e. Reconnaissance (RCV) and Armoured (ACV) could be designed subsequent to the ICV. Finally, we assumed that both the RCV and ACV variants, as is the case with all other families of combat vehicles, would be more expensive than the ICV variant cost of \$1.4 million/unit. It was never our assumption, as stated in Mr. Smith's letter to you, that the TH 495 would only meet the ICV variant.

In the absence of concrete information which would alter the logical assumption that the Thyssen 495 proposal relates to the ICV variant, the increased O & M costs of \$115 million are still valid as we would be procuring and operating an ICV some eight years before it is required.

With respect to the \$200 million incremental costs resulting from inefficiencies, this is entirely dependant on whether or not Thyssen would be successful in winning the contract for the remaining MRCV variants (i.e. that part of the project remaining after any initial directed contract to Thyssen). Should Thyssen win, we would not have a mixed fleet and the \$200 million in incremental costs would disappear. In the best of circumstances, it is possible that Thyssen would enjoy an advantage leading to the subsequent acquisition of the other two variants, thereby leading to a relatively homogeneous fleet. At the same time, it should be noted that DND would need some \$3.3 Billion to purchase our required number of vehicles from Thyssen as opposed to the \$2.1 Billion we have budgeted in the time frame 1995-96 to 2004-05. However, in the more likely case, there will have to be an open competition which would involve all factors including "affordability". Given the high cost we would pay for our initial vehicle through a directed contract to Thyssen (for whatever variant), the small amount of funds remaining to us for purchase of the final two variants, the consequent need to trade-off quality for quantity (low-cost), and the high cost of the Thyssen vehicle as compared to other contenders, it is doubtful in the extreme that Thyssen could be cost-competitive in any such competition. A mixed fleet would be the reality, and the increment of \$200 million for inefficiencies would stand.

.../3

SECRET

Yours sincerely,

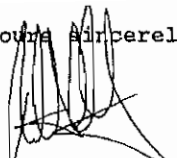

R.D. Gillespie

c.c. Mr. Peter Smith, ACOA

SECRET

RCMP.SCH\_INQ.HQ.STXT.34.0020

4 of 4

000338



MEMORANDUM OF UNDERSTANDING

This Memorandum of Understanding is an expression of intent, but it is a condition precedent to the requirement to perform hereunder, that the parties enter into a more detailed contract, more specifically outlining their terms of agreement. The parties agree to proceed forthwith to finalize such contracts.

This document signed this      day of                      between:

THE GOVERNMENT OF CANADA, as represented by:

- i) the Minister responsible for the Atlantic Canada Opportunities Agency (hereinafter called "the ACOA Minister"),
- ii) the Minister of National Defence (hereinafter called "the National Defence Minister"); and

BEAR HEAD INDUSTRIES LTD., a company incorporated under the laws of Nova Scotia, a subsidiary which is one hundred (100%) percent owned by Thyssen Industrie AG of the Federal Republic of Germany (hereinafter called "the Company").

WHEREAS the Government of Canada desires to foster the economic expansion and industrial development of Atlantic Canada;

WHEREAS the Company must have in place a North American heavy-industry manufacturing facility on an urgent basis, and desires to establish such a facility in the Province of Nova Scotia;

WHEREAS the Government of Canada recognizes that the proposed facility represents an important economic development and diversification of the industrial base of Nova Scotia; and

WHEREAS the Company and the Minister of the Atlantic Canada Opportunity Agency, and the Minister of National Defence, on September 27, 1988 signed the document known as an "Understanding in Principle", which stated in Clause 6 that it would be replaced at a later date by this Memorandum of Understanding (hereinafter MOU);

April 9, 1991



8470-5  
vol. 2

1. In accordance with this MOU the Company shall establish a diversified heavy-industry manufacturing facility in the Province of Nova Scotia, which will:

a) create in Nova Scotia a new and diversified activity in the Canadian civilian and defence industrial base, with access to the North American markets, under the Canada/United States Free Trade Agreement and the Defence Production Sharing Agreement;

b) transfer to the facility, all technology necessary for the establishment and development of this facility and its respective specialized products in both the civilian and defence sector;

c) to the greatest extent possible, source its requirements from, and promote the establishment of, small business enterprises located in Atlantic Canada;

d) employ a minimum of 500 people on a permanent, full-time basis and, where necessary, train these individuals in required skills and knowledge, utilizing, where appropriate, local educational facilities.

2. In accordance with this MOU, the Government of Canada, in order to facilitate the establishment of the Company's heavy-industry manufacturing activity in Nova Scotia, will:

a) enter into negotiations with the Province of Nova Scotia, to put in place financial arrangements for the co-funding of required physical infrastructure, up to a maximum value of \$15 million;

b) entertain an application by the Company to the Minister of National Revenue for duty remission on the importation of machinery, parts, and components for the manufacturing of vehicles, under the Machinery and Equipment Tariff Program, consistent with this program at the time of such importation; and

c) entertain an application by the Company to the Minister of Employment and Immigration for Government participatory funding, for initial employee training.

---

April 9, 1991

8470-5  
001.2

3. In recognition of the need to proceed urgently, the Government of Canada and the Company agree to adopt a two-phased approach to the establishment of the facility.

PHASE I

4. The Government of Canada and Company agree that in Phase I, the respective parties will undertake the following:

a) the Company

(i) the Company will proceed forthwith with the construction of an initial plant, requiring an estimated initial capital investment of \$61 million, to manufacture defence products for the North American markets;

(ii) the Company will sub-contract manufacturing of major components for supply to the Thyssen Henschel - General Dynamics Land Systems joint venture which has recently been awarded contracts for the supply of TPZ Fox armoured NBC (Nuclear Biological Chemical) detection vehicles to the United States Army. [Delivery of finished components are contracted to commence in 1993.]

b) the Government of Canada:

(i) The Minister of National Defence, will place a directed start-up order with the Company for 250 Multi Role Combat Vehicles (MRCV), from Canadian production at the Company's Nova Scotia facility. Representing approximately 1/3 of the pending Canadian MRCV requirement.

[The Company estimates the acquisition cost for these 250 vehicles at \$350 Million Canadian (based on a conversion of known German costs to Canadian for baseline vehicles). After DND specifications are established, final price will be determined using the principle of open audit of costs and agreed profit.]

---

April 9, 1991

8470-5  
UOI-2

provided the Company commits to:

- a) manufacture in its Nova Scotia facility, these and other vehicles from its entire technology range, according to the operational requirements of the Government of Canada,
- b) meet the Government's requirements for quality, delivery, and logistic support, including personnel training,
- c) provide significant regional and industrial benefits;
- d) provide independently or with the Government, bridge-financing arrangements in relation to the vehicles to be delivered to the Canadian MRCV program;
- e) agree to announce and proceed immediately with construction of it's plant with the following schedule:

June 1991:	Contract signed with Government of Canada. Announcement of project go-ahead
Oct. 1991:	Engineering finalization and commencement of construction contracts.
Mar. 1993:	Plant complete and staffed.
June 1993:	- Commencement of delivery of Fox NBC components to US Army Program
To be announced:	- Commencement of Production of Canadian TH 495 vehicles for MRCV program

#### PHASE II

5. The Government of Canada and Company further agree that in Phase II, the respective parties will undertake the following:

---

April 9, 1991

8470-5  
vol. 2.

a) the Company

(i) the Company will proceed not later than twelve (12) months after the commencement of Canadian MRCV production under Phase I, with diversification into heavy civilian manufacturing production targeted at Canadian and international markets, for environmental protection technology; and

(ii) the Company will provide within six (6) months after the commencement of Canadian MRCV production under Phase I, financial details including product and market projections associated with Phase II;

b) the Government of Canada:

the ACOA Minister, will consider assistance to the Company, under established regional and industrial development programming, consistent with such programs at the time the project becomes eligible for such assistance.

6. In recognition of the very considerable financial, technical, and other capabilities realized by Bear Head Industries, as a wholly-owned subsidiary of Thyssen Industrie AG, and the importance of such capabilities to the Government of Canada, by copy of the enclosed agreement between Thyssen Industrie AG and Bear Head Industries, Bear Head Industries hereby discloses a commitment by its parent to retain its one hundred percent ownership in Bear Head Industries, for a period of at least five years in duration, commencing from the date of the award of the contract (noted in paragraph 4b (i) above) to Bear Head Industries.

Should Thyssen Industrie AG wish to divest, in whole or in part, its holdings of Bear Head Industries, prior to 5 years, Bear Head Industries will in advance seek written consent from ACOA, and will remit to the Government of Canada a sum equal to fifty percent of the aggregate value of the federal contribution to infrastructure (noted in paragraph 2a above).

---

April 9, 1991



8470-S  
2.100

CONFIDENTIAL

6

THE GOVERNMENT OF CANADA

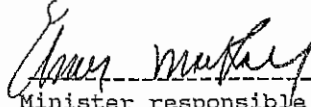

-----  
Minister responsible for the  
Atlantic Canada Opportunities Agency

-----  
Minister of National Defence

BEAR HEAD INDUSTRIES LIMITED



-----  
Mr. Karlheinz Schreiber, Chairman

---

April 9, 1991

8470-5  
vol. 2



**Karlheinz Schreiber**

Suite 908, 350 Sparks Street, Ottawa, Ontario  
Telephone: (613) 563-3321 Fax: (613) 563-3321

**PERSONAL AND CONFIDENTIAL  
HIS EYES ONLY!**

---

April 19, 1991

The Right Honourable  
Brian Mulroney  
Prime Minister of Canada  
Langevin Block  
80 Wellington Street  
Ottawa, Ontario  
K1A 0A2

Dear Prime Minister:

As a follow-up to our meeting of last week, I have noted a few items which I feel are important for you to be aware of.

Since you made it very clear in your statements what your principles are, and how much you care about your people and especially about the safety of your Armed Forces who serve them, I am more determined than even before to support you through pursuit of the Thyssen-BHI project.

Unfortunately, to fulfil this commitment to you, I think I have to help you to identify information which may have misled you on the Thyssen project. So far during my experience on this project, I have been frightened to think this may also occur on other initiatives.

Attached, you will find an "Aide Memoire", and comments in response to questions from the Minister of ACOA.

If you will allow me, I would suggest that you keep this all for your personal interest as I intend to table these attachments during my up-coming meetings with your officials.

I think there is no need for me to comment on the continuing meeting we had with Mr. Tellier after your departure, as I know, Fred will do this. Rather, let me lead your attention to items which you were interested in.

In your presence, Mr. Tellier told you that DND could buy the appropriate MRCV for Canadian Forces for a price of \$500,000. This is just nonsense.

Stanley Hartt showed me a report from Paul Tellier, dated August 10, 1990, in which it was stated, "Mr. McKnight is strongly opposed to this project on financial, policy and operational grounds". This cannot be true, for Bill McKnight told me several times, in the presence of Elmer MacKay, that he would love to go for the project but that he unfortunately had insufficient funding in his department.

In the same document, General Motors Diesel Division in London, Ontario is described as successfully competing in the field of armoured vehicles and has obtained an important contract in Saudi Arabia. This is not true.

From information contained in a separate document prepared by ACOA in December 1990, I was asked by Minister MacKay to respond to comments from External Affairs, stating their concern that by directing a major military purchase to a non-US (i.e. German) source, Canada will initiate US trade interests and threaten access to the US defence market.

This comment is misleading, for the entire Thyssen-BHI project was described to the Under Secretary of the US Army and received his endorsement. This meeting took place in the presence of the Minister Counsellor of the Canadian Embassy.

If there are any doubts on your side, on the statements given to you by the Company, and the merits of the proposal, the Company is prepared to submit to an appraisal of these issues by an internationally recognized authority.

Lastly, about the comments of Mr. Fowler who told us from the beginning that we "are not going to get this project" and the equally unbelievable remarks of Lt.Gen Huddleston, I will only remind you of our discussion.

As an independent individual, and your true friend, I can only tell you, that in my opinion, the Thyssen project, realized in Canada, will be the best economic and political tool, I can possibly imagine.

I would appreciate if you could find the time that I could explain all this in greater detail.

Wishing you all the best and with

Warm regards,



Karlheinz Schreiber

## AIDE MEMOIRE

1. Q: Is it in fact a stated policy of the Government to use DND Capital program spending to promote regional economic development?

A: Yes, as stated in the White Paper on Defence in June, 1987, and publicly declared Cabinet policy.

2. Q: Is it the intent of the Government to promote exports of products made in Canada, and within this goal promote the development and manufacture of products in Canada which can be successful in export markets?

A: Yes. All parties would agree that increased exports are vital to Canada's overall economic recovery, and future survival as a player in the global market.

3. Q: Is it agreed that the Canada-United States Free Trade Agreement (FTA) and Defence Production Sharing Agreement (DPSA) must be utilized as vital tools of entry to the US market by Canadian products?

A: Yes, otherwise the Mulroney Government's negotiation and implementation of the FTA is ignored.

4. Q: Should the branches of the Federal Government not support initiatives which specifically target the export market covered under the Canada-US Free Trade Agreement?

A: Yes, and the Thyssen BHI project is an example of such an initiative.

5. Q: Regarding the Army's MRCV project, relative to DND's overall program, one can observe that the Air Force is equipped with modern fighter jets, notably the CF 18, while the Navy has begun to receive their new frigates which will be followed by the NSA helicopters and the new minesweeper vessels. However, it appears the Army is left with obsolescent combat vehicles.

With this in mind, are there any significant changes to army equipment from the status described in testimony to the Senate Defence Committee, May 26, 1987 by then Commander of Mobile Command Gen. Jim Fox?

A: No, with respect to combat vehicles for the regular troops, no change has occurred.

6. Q: Did Army soldiers face the threat of injury from 7.62 AP (armour piercing)

ammunition while in their armoured personnel carriers during the "stand-off" with Native Canadians at Oka in 1990?

A: Yes, in fact the Leopard 1 main battle tank was deployed on the final approach to the barricades.

7. Q: Could Canadian soldiers also face threats as common as 7.62 AP ammunition penetrating their current armoured personnel carriers during assignments to UN peacekeeping missions, including the Gulf region?

A: Yes.

8. Q: Are the Canadian Forces presently able to deploy troops into a contaminated zone using vehicles with an integral NBC (Nuclear, Biological, Chemical) protective system?

A: No.

9. Q: Has the Canadian Army placed the Multi Role Combat Vehicle (MRCV) as their top priority in equipment requirements?

A: Yes.

10. Q: Is NATO (Nato Industrial Advisory Group - NIAG) working on a standard requirement for NATO nations along the lines of the MRCV requirements?

A: Yes.

11. Q: In light of the experience of the Gulf crisis, is this MRCV applicable to the future needs of our allies?

A: Yes.

12. Q: Are the parties involved aware that for example the German forces have no vehicle such as the MRCV suitable to their future participation in the planned NATO "rapid reaction forces", and will be seeking a new design?

A: Yes.



13. Q: Given Canada's international reputation as pioneers and leaders in the in the concept of UN peacekeeping, would a Canadian made vehicle not enjoy an ideal trade mark in the maple leaf?

A: Yes.

14. Q: Are the parties involved agreed that departure from the prospect of export potential as a necessary feature of the vehicle which is procured as Canada's MRCV may have serious negative consequences in the cost of operation and maintenance, due to the absence of inter-operability of such a vehicle among Canada's allies.

A: Yes.

15. Q: What are the essential characteristics in a peacekeeping and Multi Role Combat vehicle (MRCV)?

A:

- 1) air transportable in the Hercules C 130
- 2) armour protection against a minimum of 7.62 AP ammunition
- 3) protection from biological and chemical weapons
- 4) high mobility across a wide range of terrain
- 5) family concept in design, to include capability for reconnaissance, infantry transport, armoured combat and other variants
- 6) capacity for increased armour protection through in-field application of "modular add on armour", to meet threat in mid intensity conflict (eg. Gulf crisis)
- 7) suitable for deployment in internal security role (eg. Oka, 1990)

The Thyssen proposed vehicle (TH 495) is being developed to meet these requirements.

16. Q: Is it agreed that these characteristics also meet the requirements of other armies?

A: Yes, very likely.

17. Q: If this is the case, will this not bring the Thyssen TH 495 vehicle significant export opportunity in these markets?

A: Yes.

18. Q: Is there an "off the shelf" vehicle existing from a western industrial country and selling at a price of \$500,000.00, which meets the Canadian MRCV requirement?

A: No, there is no such vehicle available for that price. Furthermore, to the Company's knowledge, no competitor is able to produce the vehicle needed to meet the Canadian MRCV requirement at the same quality and at a lesser price than has been offered.

19. Q: Is there another successful international manufacturer with an existing or developmental vehicle (which meets MRCV characteristics) who is willing to transfer their technology and the major share of future export production to Canada?

A: Unlikely.

20. Q: Moreover is there such a manufacturer who, in addition to Canadian production of this vehicle, will introduce a diversification of operations in the environmental protection sector and the variety of industrial activity similar to the Thyssen range of technology?

A: No.

If all will agree with these points made above, they will also agree that whichever manufacturer can enter the market first will secure a distinct advantage in this business.

The answers provided here are based upon internal knowledge and advice available to the Company, including our Canadian defence advisor Lt.Gen. Jack Vance (ret'd), who completed his service in the Canadian Forces in 1988 as VCDS.

To explain to those, to whom the MRCV concept is not a daily point of discussion, it is useful to observe the fundamental determinants of vehicle design which will define the elements of the end product:

Cargo door dimensions of the Hercules C 130 aircraft determine limits on a vehicles width and height

Lift capability of the aircraft determine limits on vehicle's transportation weight

Protection requirements dictate the amount of "add-on armour" and thus the operational weight of the vehicle.

Mobility requirements and the specified terrain determines the selection of power pack and wheels or tracks

After consideration of these key elements, the remaining specifications deal with equipment and systems needed to fulfil assigned rolls.

Since major assemblies and component prices are known and available within NATO, and since it is proposed to supply the vehicle on the basis of open audit - agreed profit basis, it should be agreed that there is nothing undisclosed in final costs on the vehicle.





**BEAR HEAD INDUSTRIES LIMITED**

---

**MEMO**

**TO: Jürgen Massmann  
Karlheinz Schreiber**

**FROM: Greg Alford**

**TEL: 613-563-3321  
FAX: 613-563-7648**

**DATE: April 30, 1991**

**SUBJECT: Attached is a memo on the background and status of BHI's offer, as requested  
by the Hon. Elmer MacKay**

---

All information is based on the papers written during the last visit to Ottawa by Karlheinz, and the letters to ACOA during November-December 1990.

I believe the Minister intends to use it as background in his discussions with his cabinet colleagues.

Regards,

Greg

## THYSSEN-BEAR HEAD INDUSTRIES

### BACKGROUND

#### The Company:

THYSSEN AG is one of Germany's largest industrial concerns, employing some 147,000 persons worldwide, in broadly diversified industrial activity.

THYSSEN INDUSTRIE AG, in response to the regional development objectives of the Federal Government, has been endeavouring since 1985 to establish a manufacturing capability in Nova Scotia.

THYSSEN-BEAR HEAD INDUSTRIES (BHI) is a Canadian subsidiary, wholly owned by THYSSEN, and mandated to establish a North American "heavy industrial" production facility, drawing on the entire range of technology within THYSSEN.

Among the initial commercial activities targeted for this facility will be environmental protection technologies for the treatment of coal fired power plant's flue gases, and the composting of organic components of municipal solid waste. Other commercial areas of activity targeted include: industrial automation, and offshore oil exploration and recovery equipment.

The defence production aspect of the Thyssen-BHI venture is intended as a stable high technology manufacturing base upon which the aforementioned diversification will be based.

### THE PROPOSAL

The estimated capital investment by Thyssen is \$ 61 Million (Dec 1990)

The estimated direct employment is expected to reach 500 by 1994

Indirect employment has been estimated at 750 to 1000 .

No establishment grant programs as administered under the Department of Industry Science and Technology are requested.

Infrastructure costs for a "greenfield site" in 2 km proximity to existing roads and services are estimated at \$12.2 M (Dec, 1990)

It is anticipated that 1/3 of this would be contributed by the Province of Nova Scotia, and 2/3 (8 Million 12/90) by the Federal Government through ACOA.

To get the Thyssen-BHI project started, two key elements are necessary:

1. Land and Infrastructure Establishment

Sufficient land (300 acres) and basic industrial infrastructure and services (including rail spur) is to be provided at a site mutually agreeable to the Government of Canada and the Company.

2. An Order for 250 Armoured Vehicles

DND has determined a need for a Multi-Role Combat Vehicle (MRCV) capable of a variety of missions including peace-keeping. THYSSSEN-BHI would propose to manufacture a variant of their new design TH 495 which is being designed in parallel with the DND program.

(The contract for 250 vehicles needed to "kick-start" the BHI facility will represent about 1/3 of the proposed MRCV requirement).

3. TH 495 highlights:

- weight class: 16 metric tonnes
- air transportable: via Hercules C-130 aircraft
- protection: armour, basic: 7.62mm AP (armour piercing)  
armour, add-on: against 30mm (AP)  
environment, NBC protected (Nuclear, Biological, Chemical)
- family concept design: variants include - reconnaissance, combat and infantry

- unit price: \$1.4 M (Canadian)  
estimates based on conversion of known German costs to Canadian for baseline vehicle

- logistic costs: based upon Thyssen experience as prime contractor on a variety of armoured vehicle programs, a factor can be applied to unit cost to estimate the associated costs of tools, spares, technical documentation, training, operation costs and maintenance costs.  
For a program of 250 TH 495 for Canadian DND, we would estimate the logistic costs factor:  
1.17 over a 3 year life cycle  
1.30 over a 10 year life cycle

- total program cost: reflects acquisition costs combined with logistics costs.  
Assuming a 250 unit start-up order:

1.4 M unit cost  
X 250 unit start-up order  
\$ 350 M acquisition cost

add + 59.5 M logistic costs over first 3 years

Total program cost \$ 409.5 M over 3 years

or for 10 years 1.4 M unit cost  
X 250 unit start-up order  
\$ 350 M acquisition cost

add + 101 M logistic costs over 10 years

Total program cost \$ 451 M over 10 years

Financial impact of the project will spread over multiple fiscal years. For purposes of demonstration, it has been assumed the project will be engaged now and deliveries to the Canadian MRCV program will commence in FY 1993/94.



FEDERAL EXPENDITURES FY: (1990 Dollars)	1991/92	92/93	93/94	94/95	95/96	96/97 to 2001	TOTAL:
FEDERAL INFRASTRUCTURE (ASSUMES 30% BORN BY PROVINCE)	8 M						8 M
VEHICLE ACQUISITION COSTS (ASSUMES 250 UNITS DELIVERED OVER 3 YEARS)			42 M	154 M	154 M		350 M
LOGISTIC COSTS (INCLUDES TRAINING, DOCUMENTATION, SPARES, MAINTENANCE, ETC)				15 M	15 M	71 M	101 M
TOTAL:	8 M		42 M	169 M	169 M	71 M	459 M

### OPTIONS:

i) Should it be agreed necessary, the Company could offer bridge-financing in association with the Canadian MRCV program.

ii) It is recognized that the Government may wish to contract now, but to delay commencement of the delivery schedule of the vehicles to a fiscal year later than shown. In such case, given a firm production contract, the Company is willing to proceed. It is the Company's intention to proceed with start-up of the facility to achieve production in 1993, based on subcontract work for the Thyssen Henschel/General Dynamics order for the supply of Thyssen Fox NBC vehicles to the US Army.

### PRODUCTION FOR EXPORT:

In March 1990, THYSSEN - in a joint venture with General Dynamics Land Systems - won an order from the United States Army for supply of 268 Armoured NBC (Nuclear Biological Chemical) Reconnaissance vehicles, with the THYSSEN Fox NBC vehicle.

THYSSEN holds a significant share of the manufacturing content committed for the North American production, and intends to place this work at the BHI facility in Nova Scotia.

To justify the choice of Canada as the North American base for the facility, THYSSEN needs the 250 units order (equivalent of one year's production) as a start-up order.

Further Diversification:

THYSSEN intends to progressively introduce through this Canadian operation varied technologies of THYSSEN INDUSTRIE AG.

Market:

Primary market envisaged is North America using Canada as a base for participation in the Canada-US Free Trade Agreement and the Canada-US Defence Sharing Agreement.

Timing:

With a commitment for 250 MRCVs from the Government of Canada, THYSSEN will commence construction of the THYSSEN-BHI facility in Nova Scotia. The time required to establish the plant is about 24 months, therefore a commitment to THYSSEN now will cause the plant to be in production in 1993/94.



To: LCol R Gilbert@ADM MAT@ADM MAT PEARKES  
Cc: CA Kerr@DGIIP@CS Pearkes, BL Thomas@DDIR@CS Pearkes  
Maj MK Brandon@CS@CS Pearkes  
bcc:  
From: ED Champagne@DDIR@CS Pearkes  
Subject: Thyssen  
Date: Tuesday, June 18, 1991 14:07:46 EDT  
Attach:  
Certify: N  
Forwarded by:

1. During our telecon earlier, you advised nothing new from your end e.g. Schreiber still in hospital, Alford hasn't responded, and no prognosis when meeting chaired by DM to be held. You asked for E Mail from my end.
2. Minister Wilson met recently with Elmer Mackay re Thyssen. ISTC provided talking points. Minister Wilson has ordered aide memoire on subject and transmittal letter to Paul Tellier by COB today; ISTC staff are preparing and will fax copy to me to ensure DND position properly represented. ISTC staff unaware of context of request i.e. "the issue". Have checked with PCO; to best of their knowledge, matter is quiet.
3. While dangerous to speculate, plausible that Mackay/ACOA/Thyssen trying to get powerful new industry minister (Wilson) onside. That could make whole new ball game. Recall also FM just returned from Germany.
4. For C. Kerr. Will pass up copy of most recent briefing note to MND on issue for your background info.

OTT/SDC/CCS  
34120457-





## THYSSEN BHI

Suite 908, 350 Sparks Street  
Ottawa, Ont., Canada  
K1R 7S8

TELEPHONE (613) 563-3321

TELEFAX (613) 563-7648

August 21, 1991

The Hon. Michael Wilson  
Minister of Industry, Science  
and Technology  
Minister for International Trade  
515-S Centre Block  
House of Commons  
Ottawa, Ontario  
K1A 0A6

Dear Minister Wilson:

I very much appreciate that you were able to make time from your extremely busy schedule on August 9, 1991, to meet with the Hon. Elmer MacKay and myself, allowing me to describe some of the background on the THYSSEN interest in establishing new industrial activity in Atlantic Canada.

Further to that meeting, I write to provide some additional information on our proposition. As you know, THYSSEN AG is a very large international company with over 150,000 employees worldwide, and over 200 subsidiaries. Within the THYSSEN AG GROUP, THYSSEN INDUSTRIE AG is the European centre of the capital goods and manufactured products business group.

For several years now, THYSSEN INDUSTRIE AG has held the view that the establishment of new heavy industrial manufacturing capacity in North America can be achieved from a Canadian base of operation. Critical to that conclusion was the existence of the Canada - United States Defence Production Sharing Agreement (DPSA) and the implementation of the Canada - United States Free Trade Agreement (FTA).

### *THYSSEN's Industrial Activity in North America*

In general, the THYSSEN GROUP first established industrial activity in the North American market through the 1978 acquisition of Budd Automotive. Today, some 11,000 persons work



THYSSEN BHI

---

2

in the Budd operations in the United States, while just under 1,000 are active in Budd Canada at Kitchener, Ontario. Budd Canada Inc. produces chassis components and frames for cars and light trucks, including special corrosion protection and the development of weight-optimized components.

In 1988/89 THYSSEN INDUSTRIE AG acquired Northern Elevator of Scarborough, Ontario which employs some 900 persons in the manufacture of elevators and escalators.

*THYSSEN's Plan to Increase North American Industrial Activity*

The objective of initiating North American manufacture of selected THYSSEN INDUSTRIE AG heavy industry technologies is the "raison d'être" for the THYSSEN BEAR HEAD INDUSTRIES (THYSSEN BHI) proposal. THYSSEN BHI has a mandate to establish diversified industrial operations: Phase I is planned to commence with defence vehicle production for the Canadian and US markets, and then diversify this production activity to include some of THYSSEN's environmental protection technologies. After establishing operations on the environment and defence products, the Phase II target is to further diversify into manufacturing activity based on the variety of THYSSEN owned industrial technologies which are already established in Europe and not yet fabricated in North America. This range of technologies will include:

- Shears, presses and shredders
- Mixers applicable to the pharmaceutical, food and petro-chemical industry
- Industrial automation systems, conveyors and manipulators
- Machine tool system integration
- Maritime technology relating to off-shore oil industry and ice breaking

*Industrial Benefits and Regional Source Development*

We are confident that the THYSSEN BHI proposal offers valuable industrial benefits to Canada and particularly to Atlantic Canada. The company has already made a commitment to source locally where competitively possible, and to actively assist in source development through technological assistance to small and medium sized businesses in the Atlantic region which in turn will benefit our intended base of operations in Nova Scotia through increased local sources.

The Trenton Works facility at Trenton, Nova Scotia, is of particular interest to THYSSEN BHI as a local source of production associated with the Canadian defence work. It is the



THYSSEN BHI

3

intention of the company to cooperate with Trenton Works, bringing them necessary technical assistance to execute major subcontracts for THYSSEN BHI primed contracts. The range of technology brought to Trenton Works in this situation will start with the defence sector and extend into environmental and civil industrial activity in a time frame associated with the same diversification at THYSSEN BHI. Given the current uncertainty associated with Trenton Works, THYSSEN BHI is now also prepared to consider cooperation under a variety of ownership circumstances which could include direct THYSSEN BHI equity investment or technology partnership.

Other local manufacturers already contacted in the Atlantic region for preliminary discussions include Maritime Steel of New Glasgow, NS; CBM Technology, North Sydney, NS; and Industrial Rubber, Bathurst, NB.

Outside of Atlantic Canada, the automotive industrial sector mainly located in Central Canada will be an obvious source of supply.

#### *Location*

The THYSSEN BHI location decision is presently under re-evaluation. In 1988, THYSSEN BHI had intended to avail itself of the special tax incentives established under the Cape Breton Investment Tax Credit (CBITC) available for industry settling in Cape Breton and putting assets in place and in use before the end of 1992. This deadline is now impractical for consideration against the companies original intended "green field site" plans, therefore location options are being re-examined in light of this change to the financial conditions. Accordingly, THYSSEN BHI is prepared to be flexible as to its initial Atlantic location.

#### *Start Up*

The basic proposal developed by THYSSEN BHI has assumed the establishment of a facility in Nova Scotia based on the company providing the capital investment for plant and machinery, and extending production mandates and technology transfers to the new Canadian facility. THYSSEN BHI has asked that the Government of Canada negotiate a "start-up" contract with the company to supply the Canadian DND with a minimum of 250 multi-role combat vehicles (MRCV) needed to meet part of the Canadian Army's pending MRCV requirement.

The company acknowledges that the timing now projected for the Canadian DND MRCV program may not be consistent with the company's desire to start immediately, so the company is prepared to proceed in the Nova Scotia facility first with production of major





THYSSEN BHI

4

components for an order recently awarded by the United States Army to THYSSEN in joint venture with our US partner General Dynamics Land Systems. This is a contract to supply 268 Thyssen Fox reconnaissance vehicles, with North American production on 210 units starting in 1992/1993.

It is envisaged that production at the Nova Scotia Facility for Canadian DND's MRCV program would follow in 1993/94, and production activity associated with environmental protection products and systems would commence at about the same time.

#### *THYSSEN Financial Highlights*

In the prevailing business climate, THYSSEN AG is fortunate to enjoy a continuing profit position reaching \$976 Million (pre tax) on external sales of \$27.9 Billion at year end 1990. This positive result has been combined with significant capital investments of some \$2.5 Billion and expenditures on research and development of \$618 Million.

Within the above mentioned THYSSEN AG figures are the results from the THYSSEN INDUSTRIE AG manufacturing group with pre-tax profits of \$174 Million on sales of \$6.1 Billion. From this consistent profitable performance, the THYSSEN INDUSTRIE AG GROUP made capital investments of some \$536 Million in 1990. Additionally, expenditure on Research and Development is in the order of 3% of sales annually, which represents \$183 million at year end 1990.

I cite these figures to demonstrate that, in spite of the general international economic downturn, THYSSEN remains a strong and financially healthy entity, capable of fulfilling our commitments. This contrasts with the negative trends now being experienced by many other concerns. This strength has enabled us to maintain our investment aim in Canada to establish new industrial capacity to supply the North American market, as described previously to you.

This brings me to ask for your support among your cabinet colleagues for our proposal based on the remarkable industrial benefits which would accrue to Canada and the positive contribution which it will bring to Canada's balance of payments and prosperity through introduction of new technologies to create new high value-added manufacturing jobs in a traditionally chronically depressed area of the country.

Earlier this summer, I appreciated having had the opportunity of a meeting with your



THYSSEN BHI

---

5

colleague, the Hon. Marcel Masse, Minister of National Defence, at which time I explained to him the essential aspects of our proposal. It is my understanding that the Government is now in the process of concluding its Defence Policy decisions which will be announced by Minister Masse in the near future, and at that time procurement intentions will become more clear.

I would be most grateful to meet with you and Minister Masse again, as soon after Minister Masse's announcement as possible, to reach an early decision on the issues around activation of our proposal for Atlantic Canada.

Thank you very much, and I look forward to our next meeting.

Sincerely,

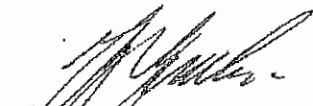

Karlheinz Schreiber  
Chairman



*Returned from P110 23/1/92*

CLERK OF THE PRIVY COUNCIL AND  
SECRETARY TO THE CABINET



GREFFIER DU CONSEIL PRIVÉ ET  
SECRETÉAIRE DU CABINET

SECRET

September 17, 1992

MEMORANDUM FOR MR. HUGH SEGAL

Thyssen BHI Peacekeeping Vehicle Proposal

This note provides an update on Thyssen BHI's proposal to build prototype peacekeeping vehicles at a new plant in east Montreal.

Background

- This spring, Thyssen Industries of Germany, which has made a number of proposals to the federal government since 1988 for financial assistance and directed defence contracts to build a new light armoured vehicle in Atlantic Canada, proposed a new directed contract from the Government to build eight prototype "peacekeeping" vehicles at a new plant in east Montreal. Thyssen was also seeking \$132 million from governments for the plant; in addition, DND was being asked to test the prototype vehicle.
- DND indicated that it did not require this type of vehicle and had no budget for it, although it would be willing to test and demonstrate it on a cost-recovery basis to assist the company. You will recall that, given the sensitivity of a new Quebec-based plant at this time, a letter was sent in July under your signature to company president, Mr. Karlheinz Schreiber suggesting that he contact the Honourable Michael Wilson to explore the suitability of various industrial development programs.

Update

- We are now advised by ISTC officials that Mr. Schreiber has not contacted Mr. Wilson nor anyone in his office or department. Thyssen representatives are understood, however, to be making the rounds of Québec Ministers' offices with a revised proposal that seeks financial assistance for a plant in east Montreal. The new proposal targets new export markets in the U.S., Saudi Arabia, the U.K., France, and Germany but no longer seeks directed contracts from DND.
- We understand that Thyssen has made presentations over the last ten days to Ministers Masse, Bouchard, Charest and Corbeil, and was also to present a proposal to the Quebec government this week.

The New Proposal

- Thyssen is understood to be prepared to put \$53 million into the project, of which \$40 million would be technology transfer benefits; it is seeking \$117 million from governments initially, and \$50 million when the plant is actually constructed. The firm has also made an unprecedented request that DND personnel work in the plant to assist in design and operational matters.
- ISTC analysts have indicated that there continues to be an oversupply of light-armoured vehicles in the western world. It is not clear whether Mr. Schreiber and his advisers would be aware that, despite the recent amendments to the Criminal Code and the Export and Import Permits Act, there might be less flexibility for a Canadian manufacturer to export such vehicles from Canada to any third world country with questionable human rights or military records, than would be the case in Germany.
- With Canadian restrictions on exports as well as highly competitive conventional markets for such vehicles, DND continues to have concerns that any new plant would soon be seeking directed contracts to assure its continued survival. ISTC also has concerns about the impact a second plant would have on the longer-term health of the current Canadian manufacturer of these vehicles, General Motors' Diesel Division in London, Ontario.
- [Mr. Masse is understood to be strongly supportive of this project and Mr. Corbeil informed us that other Quebec Ministers are also supportive. Whether Mr. Bouchard would be prepared to recommend funding the proposal from FORDQ resources is not clear at this time.]

39(a)(c)

Comment

Both FPRO and PCO have some concerns about the political sensitivity, if a Thyssen project were to proceed in Quebec when an earlier related Thyssen proposal did not proceed in the Maritimes, particularly over the next few weeks. However, it is clear Quebec ministers consider this matter to be a high priority and officials are proceeding with its assessment. The project, as noted, is complex and will require significant ministerial discussion.

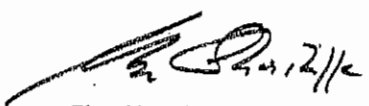
  
Glen Shortliffe





THYSSEN BHI

Suite 908, 350 Sparks Street  
Ottawa, Ont., Canada  
K1R 7S8

TELEPHONE (613) 563-3321

TELEFAX (613) 563-7648

May 13, 1992

Hon. Marcel Masse  
Minister of National Defence  
Confederation Bldg. #209  
House of Commons  
Ottawa, Ontario  
K1A 0A6

Dear M. Masse:

Following last week's meetings with the Prime Minister, the Hon. Elmer MacKay and with you, we proceeded as discussed. Due to the tragic disaster in Nova Scotia, Elmer has not been able to keep you informed of events since. Therefore, I will fill in for him to bring you up to date.

As we informed you, our next steps were to meet with officials of the Province of Québec and with some of your Army Generals.

With respect to our discussions with the Province of Québec, we have found a very enthusiastic reception in meetings with the Premier's staff and officials from his Department of Industry, Commerce and Technology. On behalf of Premier Bourassa, they have expressed their support for our proposal and are now actively assessing potential sites in the Montreal area for our consideration.

*not  
a CBS  
Promo  
by them*

We also met with four of your Senior Army Generals who share the view of the global nature of the requirement wherein allies will need vehicles of the type identified in your recently suspended MRCV program. The discussions with them underlined your views of the growing importance of future peacekeeping, as written in your April Statement of Canada's Defence Policy, 1992.

*They should be at mtg also*

Thyssen Henschel is now proceeding with one of first prototypes of a new family of light armoured vehicles. These initial prototypes are based on the TH 495 design which was



THYSSEN BHI

2

originally conceived in response to the requirements of various NATO allies, including recognition of the essential Canadian MRCV requirement as advised to industry through the German Defence Attaché on April 1991 and confirmed by you in your letter to the German MOD February 10, 1992.

To successfully complete development and to allow Thyssen and Canada to participate in the anticipated large export and co-production potential, we are extremely anxious to incorporate acknowledged Canadian peacekeeping expertise through advice from Canadian Forces operational and technical experts.

Therefore the action I am proposing will require a development contract with DND. This will permit the fabrication of eight prototypes, five in a new facility in Montreal. These latter vehicles will be furnished to DND for evaluation.

The cost of the entire contract will amount to \$132 million (CY) spread over three years. It is recognized that these funds will have to be found from other sources beyond current DND allotments and that DND's participation will be reimbursed. To avoid any misunderstanding, I wish to point out very clearly that the project under discussion has nothing to do with future vehicle procurement for the Canadian Forces. / ESTC

You must understand that I cannot proceed as agreed with the Prime Minister to organize the necessary funding, nor can a draft contract be proposed until you and I have reached agreement through a Memorandum of Understanding.

I look forward to meeting with you at your earliest convenience, as agreed last week, to discuss the next necessary steps to bring this project to fruition.

Sincerely,

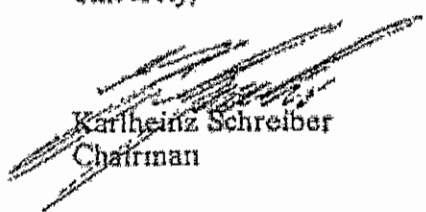
  
Karlheinz Schreiber  
Chairman

cc: Rt.Hon. Brian Mulroney  
Hon. Elmer MacKay





1 9 9 3

23. Woche  
164-201

23. Woche  
165-200

FD. J.D. F.D. B.H. 50' + H1  
HH. MS. ER. S. I. P.

Andi

Greg.

7	UHR		
8			
9			
10			
11			
12	EIMER		
13	Charvat		
14		BH1 - Frank - Red	
15			
16			
17			
18			
19			
20			

Handing Major TIL

Greg Curranin ?

Chiyoshi Moore  
Wht. NOV. 1994

24. Woche  
188-197  
Hind - Elmer. Fried  
Hind Pt. or R. 2

UHR	7	Year Party	UHR	7
8			8	
9			9	
10			10	
11			11	
12			12	
13:15		Lunch Delta	13	
		Packag. Member		
14			14	
15			15	
16			16	
17			17	
18:30		Jack Major	18	
19			19	
20			20	

UHR	UHR	UHR
7	7	7
8	8	8
9	9	9
10	10	10
11	PM. Harrington Lake. 992.42/1 11:35 Ottawa - Toronto	
12	12	12
13	13	13
14	14	14
15	15	15
16	16	16
17	17	17
18	18	18
19	19	19
20	20	20

ZT. Woche  
198-178

UHR

Hochzeit vom Georg?

7 Hotel Frankfurt  
Bauhaus

Schiller Termin

8 Georg. Schillerabend  
Hoch-Georg. Markt Georg.

Lange Lampen Mische?

9 TEL. Babels.

Preis - Medaillen

10

Br. M. Mh.  
n. Büssel

11

Kranke

12

Dicke - PVA

13 TEL. EIMER

\_\_\_\_\_

14 Memoranden,

Bismarck

15 TEL. Georg. Schiller.  
Fisch. Gans?

16

17:30 Essen bei Aude

18

19

20

UHR

7 Babels Termin.

8 Georg. Schillerabend Nr. 6

9

10

11

12

13

14

15

16

17

18

19

20

Abendessen

Compass H/An  
889. 844. 545

ZT. Woche  
187-178

ZT Woche  
192-173

Horst Spind

Mordring

7 A B S

10 Joff USA

12 1/2

Tyck Sandig-Bernd 8 Mio  
+ Rausgylf 8 Mio

UHR	7	UHR	7
8		8	Wingsen / Beckmann
9		9	
10		10	Hiddelmann Bettou - Rid
11		11	
12		12	
13		13	
14		14	Ed. Noor
15		15	HEMAY - Thysse Plethman
16		16	
17		17	
18		18	Henkehof
19		19	
20		20	

237.030.2.588

Platz.  
2 MRD Saudi

EIMER DO. bueden.

Bissee

Wieder  
Winfried

SA 4.25

Samstag 17. Juli

SU 20.30

Sonntag 18. Juli

SU 20.29

28. Woche  
199-167

1

Friedrich Bor

28. Woche  
199-166

*Milger*

*Wieder*

UHR	UHR
7	1
8	11
9	9
10:50 <i>10. Hagen</i>	10
11	11
12	12
13 <i>13. ELMER.</i>	13
14	14
15	15
16	16
17	17
18	18
19	19
20	20



30. Woche  
212-153

SU 20.11

SA 4.46

Sonntag 1. August

SU 20.10

Bismann Keller

Gründung der  
Eidgenossenschaft (Schweiz)

BOB Mladen  
Hochzeit

7	UHR	7	UHR
8		8	
9	Tel. Kader/Mass'n 2 Tel. Hochzeit	9	
10		10	
11		11	
12		12	
13	Tel. ELMER	13	
14		14	
15		15	
16		16	Tel. Bob & Lorry Hochzeit
17		17	
18		18	
19		19	
20		20	

31. Woche  
214-151

31. Woche  
215-150

Korb

Niemann

Lehmann

Edith Stöcker

# Akt Bismarck #

# Akt BHI

Max Far Tamin Fick

Paula Koning

Wimman Spwi?

Act. Grandhotel

Hotel in d. G.

Pasche.

UHR

11:13

11:13

11:13

7

8

9

10

11

12

13

14

15

16

17

18

19

20

Erwano vq. Raum 2  
Route 47. Jagel

Dr. ELMER

Mr. Gerner!

Brunel Roden / Jagel.

NR

CALL HANSEN

Fogbenack / Brand  
081 51. 12445

*Chrysler Lager Canada  
u. a. Pickering*

UHR		UHR	
7		7	
8		8	
9		9	<i>Asseie Canada.</i>
10		10	
11		11	
12		12	
13	<i>TOL. ELMER.</i>	13	
14		14	
15		15	
16	<i>TOL. BOB HEDDIN</i>	16	
17		17	
18	<i>Spartan Lager Park</i>	18	
19		19	
20		20	

*TOL. FRIEDL*

147. 83. 75. 95. 11:42

1993

Sonntag 22. August

SU 18.30

156. 95. 58. 95. 12:00

Montag 23. August

SU 19.28

33. Woche  
294-131  
Fair Canada:

Amorborg  
Eiswein Luigi Theres  
Reine Metallbille  
Leiche Hose  
Flauellhose

UHR	UHR
7	7
8	8
9	9
10	10
11	11:50
12	12
13	13
14	14
15	15
16	16
17	17
18	18
19	19
20	20

Barista  
OF 514. 847. 4747  
HO 514. 228. 4269

Tel. Frank ✓  
Tel. Wladimir ✓  
Tel. Elmer ✓  
Haug Tel ✓  
York Vance ✓

Tel. No Barion ?  
Fred Tel. /

Preem fny  
York Meyer  
Siddon / Ray →  
Hassel  
Anderson — Ropl. Gordon

Donnerstag 30  
Freitag 31  
Dezember  
Dezember

JANUAR 1993

Mo	3	10	17	24	31
Di	4	11	18	25	
Mi	5	12	19	26	
Do	6	13	20	27	
Fr	7	14			
Sa	1	8	15		
So	2	9	16		

SA 535

Donnerstag 26. August

1993

34. Woche  
239-127

Arthur Nigglingstr. 6.  
ELMER.

UHR	UHR	UHR
7		
8	Brian Fred	Tel. Fred ✓ Tel. Brian ✓
9		Tel. ELMER. 30. W. Fred.
10		
11		
12		
13		
14		30 Limarine.
15	30 Markt.	
16		
17		Bahn Airport Hotel.
18		
19		
20		

SU 19.20

34. Woche  
239-128

Freitag 27. August

SU 19.20

34. Woche  
239-128

613. 523. 1919  
514. 228. 4269

236. 0701

Donnerstag

30

Freitag

31

JANUAR 1994

Mo 3 10 17 24 31

Di 4 11 18 25

Mi 5 12 19 26

Do 6 13 20 27

Fr 7 14 21 28

Sa 1 8 15 22 29

Son. 2 9 16 23 30

Donnerstag

Freitag

Dezember

30

31



41. Woche  
333-33

1111

Sonntag 23. November



Montag 29. November



SU 16.19  
48. Woche  
333-32

Advent  
Mutter  
Vater  
Kinder  
Neugeborene  
Friede  
Friede  
Friede

Yoshi  
Gemeinde  
Gemeinde  
Gemeinde  
Gemeinde

Mutter  
Vater  
Kinder  
Neugeborene

Friede  
Friede  
Friede

7	Tagung mit Eltern	17	Advent
8	1. Advent	18	Advent
9	2. Advent	19	Advent
10	3. Advent	20	Advent
11	4. Advent		
12	5. Advent		
13	6. Advent		
14	7. Advent		
15	8. Advent		
16	9. Advent		
17	10. Advent		
18	11. Advent		
19	12. Advent		
20	13. Advent		

Stiefel  
Demos  
Sprekman

Elms

1	1
2	2
3	3
4	4
5	5
6	6
7	7
8	8
9	9
10	10
11	11
12	12
13	13
14	14
15	15
16	16
17	17
18	18
19	19
20	20
21	21
22	22
23	23
24	24
25	25
26	26
27	27
28	28
29	29
30	30
31	31
32	32

30

31

1	1
2	2
3	3
4	4
5	5
6	6
7	7
8	8
9	9
10	10
11	11
12	12
13	13
14	14
15	15
16	16
17	17
18	18
19	19
20	20
21	21
22	22
23	23
24	24
25	25
26	26
27	27
28	28
29	29
30	30
31	31
32	32

48. Woche  
334-31

Vielte

UHR	11H	12H
7		
8		
9	Paik	Fi big Jones Muller + Kindler
10:30	Bar/Liesgen	
11		
12		
13	EIMER	EIMER
14		
15	Noveski Fax	
16:00	Porter	
17		
18		Johnson
19	Therke	
20		

Therke  
 Grabe Parkey  
 Fax Noveski  
 Wilsbee  
 Grabe  
 Reifert / Demers  
 Muller/Keyser

11	11
12	12
13	13
14	14
15	15
16	16
17	17
18	18
19	19
20	20
21	21
22	22
23	23
24	24
25	25
26	26
27	27
28	28
29	29
30	30
31	31

Beauftragter

30

Dezember

Beauftragter

31

Dezember

7		1	
8		8	
9		9	
10		11	
11	Bor + Margrad.	11	
12:15	NOBBER		
13	ELMER		
14			
15			
16			
17			
18			
19			
20	Tal. Wieser		

Alwin  
Fiedlmann  
Toll

Meyer  
Toll

Alwin  
Wg. Müller

Andi  
Fiefler + Demmer

Müller  
Kathle

Raubach  
Michael



SA 8.18

Sonntag 12. Dezember

SU 16.13

Montag 13. Dezember

SU 16.13

49. Woche  
346-19

50. Woche  
347-18

*Stollen für Carade.*

UHR	NAME	ADRESSE
7		
8		
9		
10		
11:45	FRA	
12		
13		
14		
15	1:00 Salima RPO Botschaftr.	Botschaftr. G. H. S. Seelima 780 1502
16	1:30 Frank	W. Haertel
17	Montag.	Miller Robt. Futura Elektronik. Tel. 514. 694. 7710
18		
19		
20		

11 12 13 14 15 16 17 18 19 20 21 22 23 24 25 26 27 28 29 30 31 32

Donnerstag  
30  
Freitag

Freitag  
31  
Samstag

11 12 13 14 15 16 17 18 19 20 21 22 23 24 25 26 27 28 29 30 31 32



SA 821

Donnerstag 16. Dezember

50. Woche  
350-15

Freitag 17. Dezember

SU 16,14

1993

*Blumenthal*  
*Robert Gaud.*  
*Robert Gaud.*  
*Robert Gaud.*

7	922 00 44	
8		Robert Gaud. / FBI.
9	Honeywell 1 60 Len Alcom 1 90	30 Min Handey DRI
10		
11		# ELMER
12		
13		
14		
15		Suzen Elisabeth 2710
16		Angela Bueckert Mun. Ext. AP. Malak
17	BHL Christmas Party	
18		
19		
20		

Josh Morley  
930-10115

46:00 Bueckert Ad.  
Munich

# ELMER

27  
28  
29  
30  
31

Donnerstag  
30  
Dezember

Freitag  
31  
Dezember

JANUAR 1994

Mo	3	10	17	24	31
Di	4	11	18	25	
Mi	5	12	19	26	
Do	6	13	20	27	
Fr	7	14	21	28	
Sa	1	8	15	22	29
So	2	9	16	23	30

50. Woche  
352-13  
18.12.1942 Dr. Robben  
gas

Brian Melrosey  
47 Forden Cresc  
Westmount- Montreal  
514.369.8111

UHR	18.12.1942	UHR	19.12.1942
7	342.4771	7	
8		8	
9		9	
10		10	
11	Ruin Home.	11	ELMER Ballette
12		12	Stuart
13	fox	13	
14	Casail Hotel.	14	
15		15	
16		16	
17		17	
18		18	
19		19	
20		20	

18. DEZEMBER

1	13	20	27
2	14	21	28
3	15	22	29
4	16	23	30
5	17	24	31
6	18	25	
7	19	26	

Donnerstag

30

Freitag

31

19. DEZEMBER

1	10	17	24
2	11	18	25
3	12	19	26
4	13	20	27
5	14	21	28
6	15	22	29
7	16	23	30
8	17	24	31

51. Woche  
384-11  
Bike-Marketing  
Büchelt  
Meppen

UHR 165 7/12 = 145  
7 Col.  
8 Andre → Lübeck?  
9 jylind / FRK. Scheer?

9 Amstoc Rau Party  
10 Klaus Wiemann?  
11 Apple Tod 10/16

11 Tel. Pöppel Tandio?  
12 # Marc AC Stadler?  
13 Wg. A 340  
14 Max + Halger - Spreng?

14 Meppen?  
15 Catald Hannah Hupf.  
16 # Gothe  
17 Maertent  
18 Mohr

15 Marc AC.  
16 Landungs mann  
17 RA Fisch

18  
19  
20

17  
Fest

Frankfurt 25  
Jingland 5 CARV  
Frankfurt 240 → Hamml  
410 (108,534)

bis 10% Einkommen.  
1.3 Mio 5% 65  
Bonden bid Mel. Zuerche.

65. gem. in m...  
bis 60 000 40 000 New.  
Pabac 40 44 40 BNC.  
40 basic

Ernt Müde  
Wissler

Sparer Bank für  
Freising  
29942

700 310 00  
Bank für  
CSU (Kau) verband für  
Otho i Wissen.

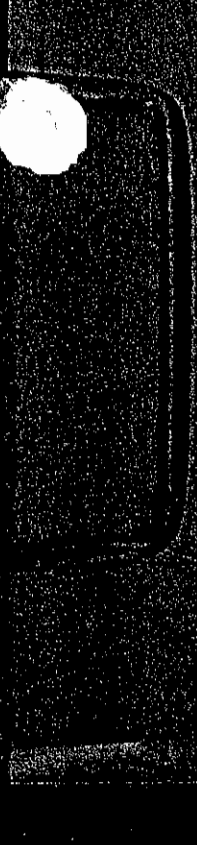

30	27
21	28
22	29
23	30
24	31
18	25
19	26

Donnerstag	30	Dezember
Freitag	31	Dezember

JANUAR 1994

Mo	3	10	17	24	31
Di	4	11	18	25	
Mi	5	12	19	26	
Do	6	13	20	27	
Fr	7	14	21	28	
Sa	1	8	15	22	29
So	2	9	16	23	30



# Karlheinz Schreiber

Suite 908, 350 Sparks St., Ottawa, Ont. K1R 7S8  
Telephone: (613) 563-3321 Fax: (613) 563-7648

PERSONAL AND CONFIDENTIAL

1/4

March 16, 1993

The Right Honourable  
Brian Mulroney  
Prime Minister of Canada  
Langevin Block  
80 Wellington Street  
Ottawa, Ont.  
K1A 0A2

Dear Prime Minister:

For more than thirteen years I have had the privilege to call you my friend. In all of those years you always gave me the feeling of confidence that I could count on you, as you know you always could with me.

For nearly thirty years, I worked closely with my friend Franz-Josef Strauss; and it was not always easy to confront him with realities that he did not like. Living with the understanding that we shared a certain degree of intelligence we agreed that the greatest treasure between friends is the truth. That includes that true friends are aware that it would never be their intention to embarrass or to influence on unreasonable grounds. Keeping this in mind and looking at the situation in Canada, I have come to the conclusion that the philosophy "wash me but don't make me wet" is not going to work any longer.

If it is your understanding that Kim Campbell is the best choice to be the next Prime Minister

Attachment: File Separately. 8

# Karlheinz Schreiber

PERSONAL AND CONFIDENTIAL

2/4

for Canada, with the capability to solve the enormous problems of the country, then it is my opinion that she should resign as Minister of Defence as soon as possible. The reason I say this is because I believe the pressure and problems she may face with the Ministry may harm her chances. I don't want to deal with the problems she may face with the anti-submarine helicopter, rather I put much more importance on the safety of Canadian soldiers in Yugoslavia and in other peacekeeping missions.

The strong feeling of friendship toward you tells me that I owe you the following report on the situation as I see it:

Today, Lewis Mackenzie (MGen Ret'd) in his first speech after his official retirement from the Canadian Armed Forces spoke out frankly and honestly without editorial control from the Department of National Defence. He spoke about the state of inadequate armoured protection of Canada's armoured personnel carriers, which he experienced first hand. He specifically criticised the cancellation of the Army's requirement known as the Multi Role Combat Vehicle (MRCV) as a primary reason for the inadequacy of equipment for Canada's soldiers who are the ones exposed to the very real and serious risks of peacekeeping.

You may also be aware of the ongoing hearings of the House of Commons Committee on National Defence and Veterans Affairs, where on the 17th of February 1993, during the appearance of Adm. Anderson, Chief of Staff to the Canadian Forces, it was confirmed by his technical assistant, LCol Peter Kenward, that the M-113 and the Grizzly and Cougar (basically all of Canada's Armoured Personnel Carriers) only have protection against 7.62 mm ball ammunition, which leaves them vulnerable to the commonly used 7.62 mm armoured piercing ammunition, and most varieties of machine gun ammunition.

You may already have known of the problems with Canada's armoured vehicles from the CBC's Journal of June 22, 1992 when they interviewed Canadian troops in Yugoslavia who when discussing the state of their armoured personnel carriers told The Journal "the bullets from one of their own guns can go through one of these things like butter and it's all the protection they have".

As far back as May 26, 1987, in testimony to the Senate Committee on National Defence, LGen J.A. Fox, Commander Mobile Command, described the desolate state of Canada's



# Karlheinz Schreiber

PERSONAL AND CONFIDENTIAL

3/4

armoured vehicle fleet in comparison to the vehicles of the Warsaw Pact then and also in comparison to Canada's allies.

The German Ministry of Defence provided us with samples of the aluminum plate of an actual M-113 armoured vehicle which had been fired on and completely pierced by a basic 7.62 mm armoured piercing round. You will recall that I showed you those samples when we met at 7 Rideau Gate together with the Hon. Elmer MacKay. As a reminder of this I enclose a photograph of the pierced aluminum plate (1.75" thick) and the 7.62 ball and armoured piercing ammunition samples. I also informed the Hon. Bill McKnight, then Minister of Defence of this situation, and later did the same with the Hon. Marcel Masse when he was the Minister of Defence as well Mr. Fowler, Deputy Minister of National Defence.

In a letter dated February 10, 1992, Canadian Ambassador Delworth, on behalf of the Minister of National Defence, informed the Ministry of Defence in Germany of the pending Army project known as the MRCV, within which the lead procurement would be the RCV (Reconnaissance Combat Vehicle): "The armoured reconnaissance vehicle, RCV, must be equipped with an armour resistant against 30 mm piercing ammunition".

On April 7, 1992 in a Department of National Defence News release, we learned that GM Diesel Division was selected on a sole source basis to produce up to 229 light armoured vehicles "enhanced for the reconnaissance role". Without doubt, this vehicle will be unable to meet the stated armament requirement for resistance to 30 mm armour piercing ammunition and it is unlikely that it will achieve any higher level of protection than the Canadian Army has in the GM vehicles of the same design which they already have.

Finally, I would like to inform you that Norwegian and French Forces refused to send their soldiers to Yugoslavia with protection less than 12.7 mm (50 calibre) armour piercing. Canada is present especially in Yugoslavia now with nowhere near that level of protection. The constant threat is that Canadian peacekeepers in their outdated armoured personnel carriers could be killed by crossfire of rifles which use basic 7.62 armour piercing ammunition prevalent in the Yugoslav conflict.

With this situation, I cannot comprehend why Canadian DND will not accept a loan of

# Karlheinz Schreiber

PERSONAL AND CONFIDENTIAL

4/4

appropriately protected equipment from their German ally especially when at present the German Forces cannot participate in the peacekeeping missions in Yugoslavia. Nevertheless, the American and British Forces were not too proud to accept such a loan from Germany of the NBC Fox reconnaissance vehicles during the Gulf crisis. I was heavily involved in the arrangements to supply those vehicles to the Americans, within 48 hours of their request.

I have no doubt that you share my real concerns on the situation of our Canadian soldiers in Yugoslavia. The question is no problem for those who are not involved or are not aware of the risk Canadian soldiers face, but we are and we know, therefore, I feel guilty that I may not have done all I could to protect those soldiers who take such risks for the preservation of peace. Let's pray that Canadian soldiers are not killed as a result of their poor equipment, because the blame for their death will rest on the inaction of the Canadian Government in not providing them with adequate equipment. Almost certainly that blame will fall on the shoulders of Mrs. Campbell, and she has had virtually no involvement in allowing this situation to go unaddressed.

If you feel that I could be of any assistance to help solve the problem, please feel free to call on me at any time.

Best regards,



Karlheinz Schreiber



TH 495

Date: 08. May 1992

No.

Figur 2: Comparison of Projectiles

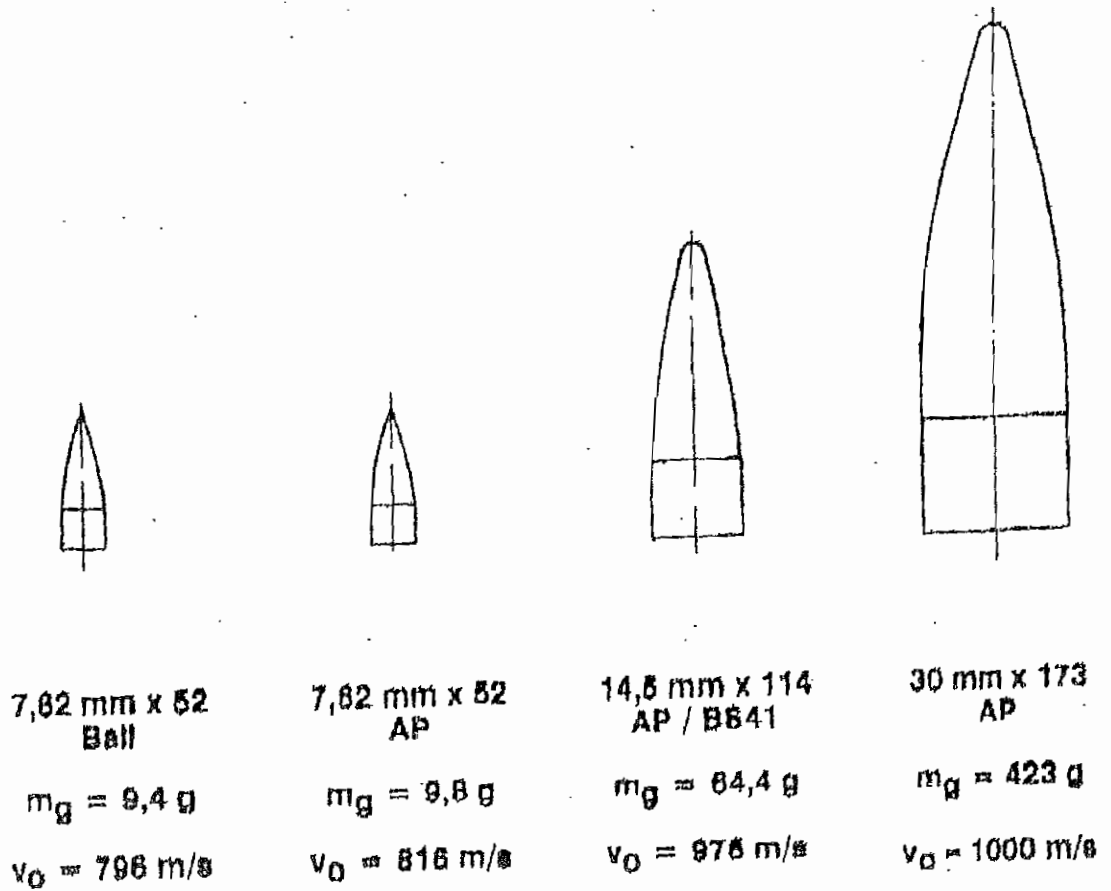

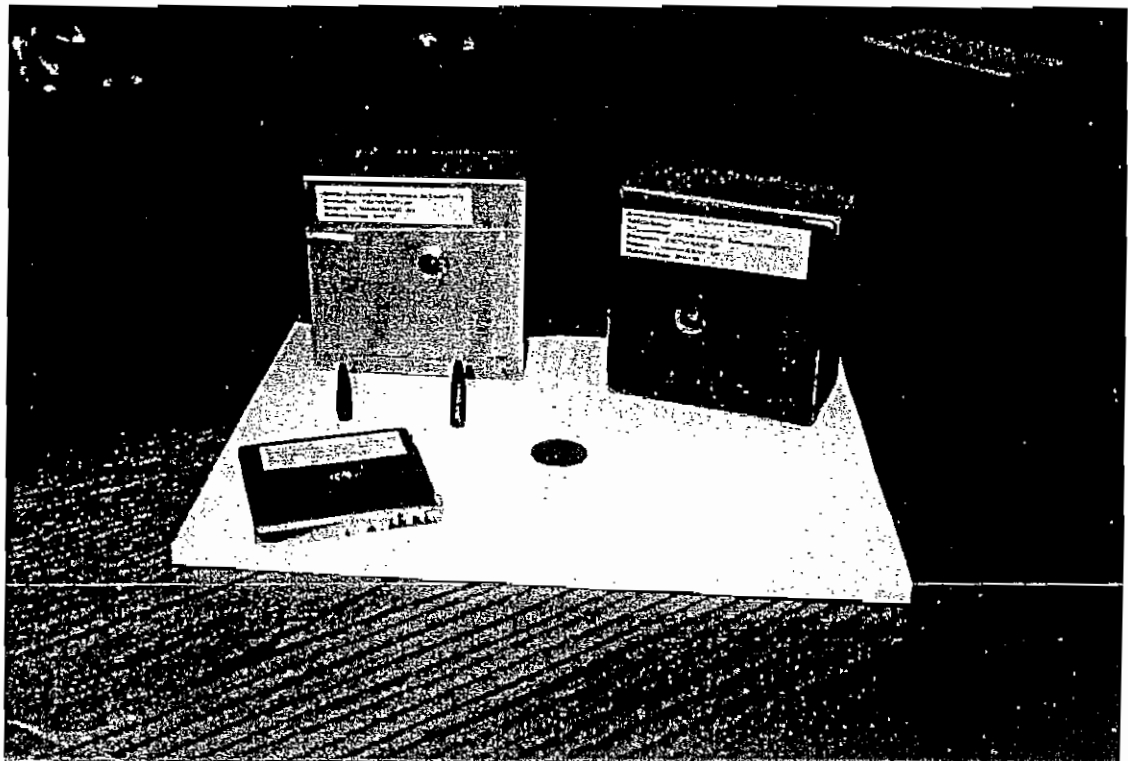
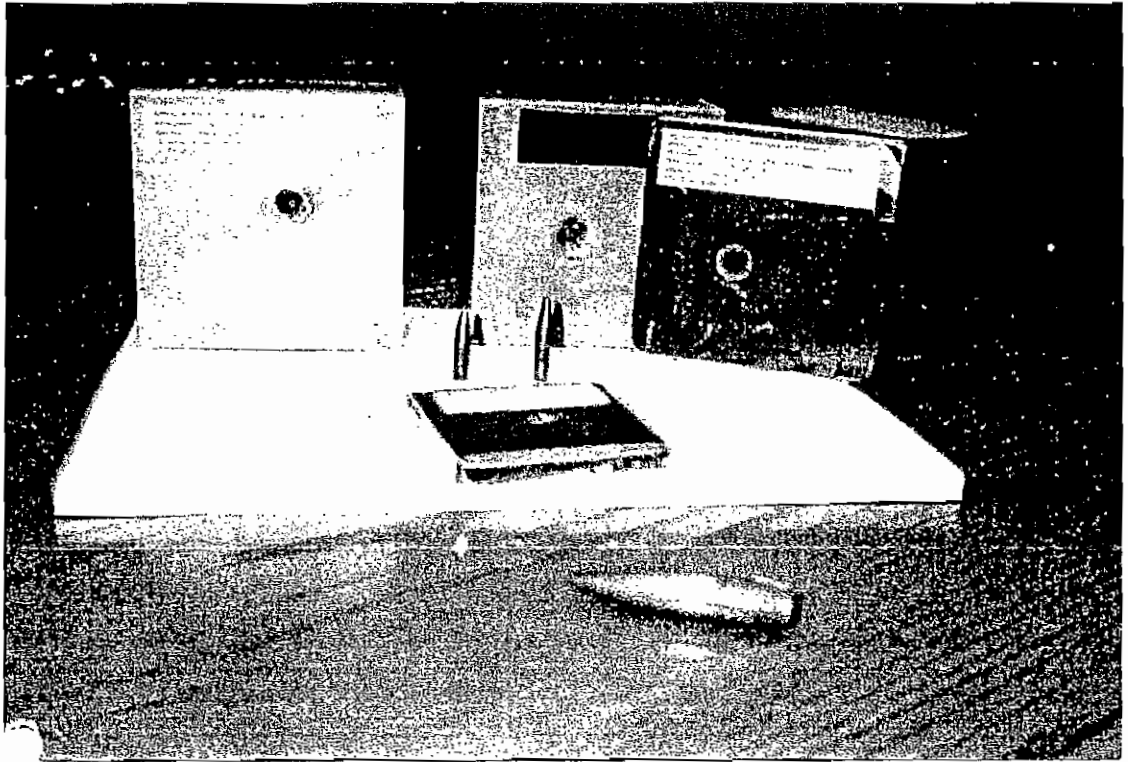



# KHS AGENDA

1 9 9 4

COMMISSION  
COPY

SA 7:56

Samstag 26. November

SU 16:22

47. Woche  
390-95  
Selima Fran Rapid  
3CE  
Bolquet

UHR
7
8
9
10
11
12
13
14
15 30 Nicerosoll Bachwitz
16
17
18
19
20

SA 7:58

Sonntag 27. November 5-11 6/8u 16:21

ZAR. Afft Baul. 35-ur v. BRG.  
Porkess  
Sonntag 27. November 5-11 6/8u 16:21

7
8
9
10
11
12
13 Elma Mochay
14
15 30 Brithwind Markt Halle Ernst
16
17
18
19
20

4 Adremann
Hassmann
Mochay
Fox Lindmann
Hornblatte
15 Papper
089.49466
4330 Bickel 15:59

5

Recher Lithman Spiegel Frankfort  
SA 8. Tel. No. 2 Dienstag 6. Dezember

SU 18.11

Mittwoch 7. Dezember

SU 18.15

49. Woche  
341-25  
NY

UHR

49. Woche  
341-24

Dr. Harbach

5.11.1931

8		8	
9		9	
10	11	10	
11	12	11	
12	13	12	
13	14	13	
14	Hockey.	14	
15		15	
16		16	Tel. Störker
17		17	
18		18	130 Meteorologen Class
19		19	
20		20	

Handwritten notes and scribbles at the bottom of the page, including the word "OFFICE" and other illegible markings.



SA 8.13

Donnerstag 8. Dezember

SU 16.14

Freitag 9. Dezember

SU 16.14

1.4

49. Woche  
34223 Maria Emplangnis  
(Osterreich)

9:10 : 9:30 Aukt

1.4  
454 Koper  
420

1974  
122 Pranel

2096  
200 Zinsen

2.296  
290 Kogn. taekhy pla  
255 Kopitel

2478  
20 Misch

7 <sup>49</sup> G: 5m / Baumhand.  
7 <sup>49</sup> paxia Litzman 2r 12?

8

9

10 Brian /  
30

11

12

13

14

15 Abreise. HAW.

16

17 LH. JFK.

18

19

20

30 u. 8:30 Stadel  
0821.41021. Bino

0161.2821.411

0821.5162.24  
Frau Riga: 4102.228

MARC. Fred.  
Reg Bill Frank

MAR 13 MW ?  
Bob Headen ?

49. Woche  
Party Enlla / Yanyan  
Abschied

# Bob Headen #

0228.81080 Woulin  
Starker

M113 aspa 900  
APC Pionye 500  
Unlod apac R Baumst.



## TIMELINE: 1999

January 28, 1999

Switzerland releases contents of Schreiber's bank accounts to German authorities. In it they found a series of coded sub-accounts for various Canadian and German politicians and businessmen.

February 22, 1999

National Post runs article quoting former Transport Minister John Crosbie who says if the RCMP ever closes the Airbus investigation,

"They'll be giving the final proof of the incompetence, and the errors, and mistakes they've made in their handling of the investigation, and even of starting it in the first place."

March 3, 1999

Peter MacKay raises Airbus affair during Question Period. (read the Hansard)

March 8, 1999

Peter MacKay states in the House during Question Period:

"Brian Mulroney is innocent of all wrongdoings and yet the Liberal government will not cease and desist the RCMP investigation. The Liberal government has a vendetta against the former prime minister which stems from the Liberals' days in opposition. There are growing concerns that the current Prime Minister's legacy might pale by comparison. The Liberals' plot for revenge is continuing to cost the taxpayers significant dollars, \$4 million and counting."

April 1, 1999

The National Post reports that Ottawa refuses to withdraw the letter sent to the Swiss. The article quotes Justice Department spokesperson Pierre Gratton who says,

"We have informed the Swiss on three occasions that [the letter contained] allegations only and we have apologized for the language used in the letter... If the RCMP were to request that the letter be withdrawn we would comply."

April 2, 1999

National Post runs editorial attacking RCMP Airbus investigation stating,

"Mr. Mulroney was not the only victim of the Canadian government's slander. Karlheinz Schreiber, the financier, was also tarred as a crook in the infamous letter."

April 3, 1999

National Post publishes an interview with Frank Moores who alleges the RCMP is dragging out the Airbus investigation as revenge for having to apologize to Brian Mulroney in its settlement with him. Moores told the Post,

"I just can't understand it. But if you ask them, they say there is still an ongoing investigation...It is total madness as far as I am concerned. It is unbelievable."

April 5, 1999

National Post runs an article saying Ottawa's withholding of information from Swiss authorities in the Airbus probe could harm relations between the countries.

May 6, 1999

Thyssen managers Jurgen Massmann and Winfried Haastert are arrested for tax evasion on money given to them by Karlheinz Schreiber.

May 7, 1999

German newspaper Süddeutsche Zeitung breaks story of Schreiber's paying millions of German marks to high ranking members of the CDU as well as the arrest of two Thyssen executives who worked closely with Schreiber.



Elmer MacKay posts \$100,000 for Schreiber's bail.

May 7, 1999

Elmer MacKay flies to Switzerland and provides a ticket to Schreiber to fly to Canada. MacKay will tell reporters at Schreiber's first bail hearing that Schreiber's flight and the arrests of the Thyssen executives was coincidental.

May 8, 1999

MacKay and Schreiber fly to Toronto. The next day, Schreiber and MacKay fly to Nova Scotia.

May 14, 1999

Peter MacKay raises the Airbus issue during Question period:

"Mr. Speaker, the last time I checked the RCMP was under the ministry of the solicitor general.

Canadians are tired of excuses and want action. It is a fact that the RCMP is suffering from a severe lack of funding due to Liberal budget cuts, yet as Bre-X gets swept under the rug the partisan obsession against Brian Mulroney continues to cost millions.

The National Post described it perfectly. It said that the government was intent on finding something to do with someone about a crime yet to be established in order to prove that it was not entirely wrong headed in its pursuit of Airbus rumours in the first place. Letting this case fester and bumble on is not an option. The solicitor general should tell Canadians when he will put an end to this futile investigation."

May 28, 1999

Peter MacKay gets into a heated debate with Jacques Saada, the Parliamentary Secretary to the Solicitor General and Deputy Prime Minister Herb Gray.

**Peter MacKay:** The atrocious Airbus investigation makes the Canadian justice system the laughing stock of the international community. The government continues to waste millions of taxpayers dollars on an investigation where the supposed prime suspect has not even been interviewed. The Liberals continue to find money for this investigation by cutting the RCMP, limiting the fight against organized crime and importation of drugs. How can the Liberal government call itself accountable as it sits back

and allows a foreign country to embark on an unlawful exercise of search and seizure when it knows full well that the exercise is not permitted under Canadian law?

**Mr. Jacques Saada:** Mr. Speaker, the only cases that I am aware of where the legislative branch tells the judicial branch what to do are in banana republics. I do not think Canada qualifies as a banana republic.

**Mr. Peter MacKay:** Mr. Speaker, this debacle continues and the Department of Justice continues its attempts to cover its tracks in what could go down in history as the biggest political witch hunt of all time. It is an international embarrassment. While the astronomical costs of this ridiculous, ill-founded investigation and litigation continue to mount, the Minister of Justice sits idly by, as did her predecessor. When will the government cease and desist in its malicious and vindictive obsession to besmirch a former prime minister, from whom it plagiarized most of his policy initiatives?

**Hon. Herb Gray:** Mr. Speaker, the Conservative Party may have interfered with police investigations. That may have been its approach. I do not know if it was, but in any event it is not our approach. We do not intend to have political interference with arm's length police investigations.

June 2, 1999

Mulroney gives an interview to CBC's Brian Stewart. He tells Stewart that the RCMP can investigate until the cows come home, "they won't find a single, solitary thing because nothing, as far as I'm concerned, was ever done wrong." (watch the interview)

June 11, 1999

Peter MacKay has a spirited exchange during Question Period with Parliamentary Secretary to the Solicitor General Jacques Saada and Deputy Prime Minister Herb Gray.



Peter MacKay asks questions about the government's handling of the Airbus investigation during Question Period.

**Mr. Peter MacKay:** Mr. Speaker, serious allegations of wrongdoing involving private holdings, campaign donations and questionable use of taxpayer money continues to plague the Prime Minister. As evidence mounts and the plot thickens, the grey fog rolls in to present the Liberal spin to cloak the facts and cover the tracks.

Now that the shoe is on the other foot, when will the government withdraw this spurious letter of baseless allegations against Mr. Mulroney sent to Swiss authorities and call an end to the ill-founded Airbus investigation?

**Mr. Jacques Saada:** Mr. Speaker, my colleague opposite has a hard time understanding the answers we give day after day to his questions, which are always the same. I will repeat for the 51st or 52nd time the same answer: the federal government has no intention of meddling in the decisions of the RCMP, of conducting an inquiry or of stopping an inquiry. It is not our role. Ours is a legislative role. The RCMP's is an investigative role.

We have no business meddling, especially since this investigation was recognized in the agreement

reached with Mr. Mulroney at the time. I really do not understand why my colleague opposite cannot comprehend that.

**Mr. Peter MacKay:** Mr. Speaker, Canadians have come to expect stonewalling and delay every time they come in conflict with the Liberal government. When issues arise citizens face a barrage of government lawyers intent on foot dragging and legal manoeuvring.

A second named party in the Airbus debacle now has a \$50 million lawsuit pending against the Canadian government. My question is for the architect of Airbus, the Deputy Prime Minister. Does the Liberal government intend to settle this matter the way it did with Mr. Mulroney, or does it intend to be dragged kicking and screaming through the courts before facing a final costly, humiliating verdict?

**Hon. Herb Gray:** Mr. Speaker, the lawsuit to which the hon. member referred that was settled involved Mr. Mulroney absolutely dropping his claim for damages. Second, what was paid was simply the legal costs.

In the written minutes of settlement signed on behalf of Mr. Mulroney, he recognized that the RCMP had a perfect right to begin the investigation and to carry it out. The hon. member ought to read the minutes of settlement and pass on to some other matters of real concern to Canadians.

August 19, 1999

Peter MacKay complains the RCMP is stepping up its "politically motivated" investigation. He tells the Toronto Star,

"I think the Prime Minister is battling shadows and it is a narcissist chasing his nemesis. He is very, very concerned that Mr. Mulroney has rehabilitated his reputation almost entirely and is going to continue to do so."



Karlheinz Schreiber is arrested in Toronto on a German warrant.

August 20, 1999

The National Post reports that Brian Mulroney has asked Schreiber to release his confidential banking records to clear the air. Author Phil Mathias writes,

"This week, Mr. Mulroney telephoned his former chief of staff, Fred Doucet, from South Africa, where the former prime minister is vacationing with his family, and asked him to organize another approach to Mr. Schreiber.

Mr. Doucet persuaded a former cabinet minister in Mr. Mulroney's government, a man who knew Mr. Schreiber, to telephone him on Mr. Mulroney's behalf and ask that the documents be released.

Over the last three years, Mr. Mulroney has interceded with Mr. Schreiber several times, both directly in telephone calls, and through intermediaries."

August 27, 1999

Arrest warrant for Karlheinz Schreiber arrives from Germany to Canada. (see request from German

authorities .pdf file)

August 30, 1999

RCMP investigators spot Schreiber in the vicinity of his Yorkville condominium. (see RCMP affidavit .pdf file)

August 31, 1999

Schreiber is arrested in Toronto on a German warrant. He is with National Post journalist Philip Mathias at the time of his arrest. Schreiber is taken to the Metro West Detention Centre. (see the arrest warrant .pdf file)

September 7, 1999

Karlheinz Schreiber is released on bond. Elmer MacKay and Schreiber's lawyer, the former Liberal Finance Minister Marc Lalonde, put up \$100,000 each. MacKay testifies that he helped Schreiber come to Canada and "I made no attempt and neither did he (Schreiber) to conceal the fact that he was in Canada."



Schreiber is released on bond and gives an interview to journalists

MacKay further says that Schreiber came to Canada at his request. (watch an interview with Schreiber after his release from jail)

October, 1999

CBC becomes first news source in the world to obtain Schreiber's bank documents. The documents reveal the existence of numerous coded bank accounts, which German authorities will decipher as the names of politicians and businessmen associated with Karlheinz Schreiber. One of the accounts is code-named BRITAN. (see the document .pdf file)



In October the fifth estate producer Harvey Cashore has several phone interviews with Mulroney spokesperson, Luc Lavoie

October 8 , 1999

CBC writes a letter to Mulroney asking him for an on camera interview.

Luc Lavoie returns a phone call from **fifth estate** producer Harvey Cashore beginning a series of taped conversations. Lavoie is told there is in Schreiber's Swiss banking documents a sub-account that might lead people to believe it was intended for Mulroney.

Lavoie asks for more information and tells Cashore,

**Luc Lavoie:** I can actually give you an undertaking in writing if you want that I won't share it with any other reporter anywhere in the world. So I mean I am not going to spread anything around. It is not my purpose here. My purpose is to get to the bottom of it." (listen to an audio clip of producer Harvey Cashore's interview with Luc Lavoie)

October 9, 1999

Luc Lavoie tells Cashore that if Mulroney's name is mentioned in any way in any bank records, it must be

Schreiber using Mulroney's name for his own purposes. He then, off the record, tells Cashore,

**Luc Lavoie:** Karlheinz Schreiber is the biggest fucking liar the world has ever seen. That is what we believe.

The interview then goes back on the record. He further states,

**Luc Lavoie:** There never was any money. And to think otherwise is really to not know Mulroney. He is too smart to do something like that. It is just too dummy. It is too damn stupid. He wouldn't do that.

Lavoie asks Cashore if he can provide more information, and if Cashore can call him back as soon as possible,

**Luc Lavoie:** If only for human reasons, try and see if we can deal with it this weekend ... Nothing is going to happen beyond you and I and he. But I am trying to help his life a little bit here. He is going nuts."

Cashore and Lavoie also discuss what happened to the money that was paid in secret commissions to Schreiber's International Aircraft Leasing.

**Harvey Cashore:** I would like to inform the public about where that money went.

**Luc Lavoie:** Yeah, well.

**Harvey Cashore:** Wherever it went. Wherever it went.

**Luc Lavoie:** Yeah, okay, it didn't go to Mulroney.

**Harvey Cashore:** I want to find out where the money went, wherever it went.

**Luc Lavoie:** Yeah, but it didn't go to him.

**Harvey Cashore:** You say that, and I've heard you say it.

**Luc Lavoie:** He said it himself, under oath.

**Harvey Cashore:** Right.

**Luc Lavoie:** So it would be major perjury right?

**Harvey Cashore:** But why does that mean that I can't ask a question about where the money went. Why can't I ask that question?

**Luc Lavoie:** Sure, you did, and I told you, I don't know where it went. It didn't go to him. (listen to an audio clip of producer Harvey Cashore's interview with Luc Lavoie)

October 13, 1999

Cashore and Lavoie have third phone conversation. Lavoie says of Mulroney,

**Luc Lavoie:** His perspective is pretty fucking clear. He never received a p - He never received a



penny connected with any of this stuff. (listen to an audio clip of producer Harvey Cashore's interview with Luc Lavoie)

October 16, 1999

Lavoie and Cashore have a last telephone interview before program airs. Cashore is warned that the CBC face the consequences for what it says on the show.

October 17, 1999

Mulroney contacts Schreiber's lawyer Robert Hladun and asks him to ask Schreiber for a written statement indicating that at no time did Mulroney solicit or receive compensation from Karlheinz Schreiber.

G rard Tremblay phones Robert Hladun and asks for a letter to keep on file from Schreiber, which is not to be disseminated, so that he can send a letter to the CBC which "would in his opinion shut down the airing of **the fifth estate** story on the "Airbus"—October 20th.

Mulroney contacts Hladun and tells him he has instructed Tremblay to send a letter to **the fifth estate** "indicating that if there was the slightest implication that Mr. Schreiber, Mr. Moores and Brian Mulroney were involved in any way then there would be terrible consequences.

He would issue the letter but first wanted an assurance or comfort in writing from Mr. Schreiber saying that he would confirm what he had publicly on many occasions, that at no time did Brian Mulroney solicit or receive of any kind from Schreiber. Mulroney called Hladun again that day, at which time Mulroney was told "I was no sure whether or not a letter would be forthcoming."

October 18, 1999

Mulroney lawyer Gerald Tremblay sends a letter to the chair of the CBC board of directors threatening to sue every board member if the coming **fifth estate** program is defamatory. ( see the letter .pdf file)

October 20, 1999

National Post publishes story saying **the fifth estate** will report on the BRITAN account. Journalist Philip Mathias will write that "both (Schreiber) and Mr. Mulroney have denied that any money has ever passed between them." The newspaper, in an editorial, will also accuse **the fifth estate** of being on a fishing expedition. It says the new information the CBC is preparing to broadcast is "false" and "preposterous."

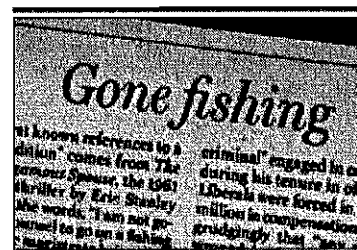

National Post publishes an editorial about the fifth estate's upcoming story

After the National Post runs its article and editorial speculating about **the fifth estate** connecting Mulroney to the BRITAN account, **the fifth estate** decides that the off the record comments by Luc Lavoie were on the record. (see the editorial and the story .pdf file)

**the fifth estate** decides to run Lavoie's off-the-record comment calling Schreiber "the biggest fucking liar the world has ever seen. That is what we believe."

Schreiber is watching that night. "I could not – my friends, my family said well, is he sick?" Schreiber recalled his reaction to Lavoie's statement to the CBC. "So then my other friends call me, oh Brian is furious. He wasn't aware what Luc Lavoie is saying. But he said we, and all this stuff."

November, 1999

An arrest warrant is issued for former CDU treasurer Walther Leisler Kiep. He admits that he accepted 1 million German marks from Karlheinz Schreiber touching off the biggest post-war scandal in German history.

November 2, 1999

Schreiber notifies Mulroney spokesperson Luc Lavoie that he believes he has been defamed by Lavoie's comments to **the fifth estate**. (see the statement of claim .pdf file)

December 8, 1999

The RCMP obtains a search warrant to raid the headquarters of Eurocopter in Fort Erie. The police are looking for information about secret commissions paid on the purchase of MBB helicopters for the Canadian Coast Guard.

December 13, 1999

RCMP officers raid Eurocopter facility in Fort Erie.

December 26, 1999

Schreiber goes to Fred Doucet's home after receiving an unexpected invitation. He says he tells Doucet "you tell your friend if under what circumstances ever I have to testify, I am not going to commit perjury for him. Makes this very clear to him."

December 27, 1999

Doucet calls Schreiber and meets him again. This time he gives Schreiber a paper and asks him to sign it. The paper was a Mandate,

"to provide a watching brief to develop economic opportunities for our companies, including traveling abroad to meet with government and private sector leaders to assist in opening new markets for our products and to report regularly to us in this regard. In this context, priority should be given to opportunities relating to Canadian based manufacturing of peace keeping and/ or peace making military equipment in view of Canada's prominence in this area. The mandate will be for a period of three years. The fee to cover services and expenses is set at \_\_\_\_\_ for the period.

next



**Mulroney asks Schreiber to clear the Airbus air: Former PM wants businessman to release bank records; [National Edition]**

*Philip Mathias. National Post. Don Mills, Ont.: Aug 20, 1999. pg. A.3*

**Abstract (Summary)**

Mr. [Karlheinz Schreiber]'s bank records are the missing piece of an RCMP investigation into allegations that he paid a \$5-million bribe to Mr. [Brian Mulroney], allegedly to ensure Air Canada bought \$1.8-billion worth of Airbus aircraft in 1988. Mr. Schreiber was alleged to be acting as a lobbyist for Airbus.

The Schreiber bank accounts will be released to Canada if both the Federal Court and the Bundesgericht rule against Mr. Schreiber. If either rules in Mr. Schreiber's favour, the Airbus affair will likely come to an end.

Black & White Photo: (Brian) Mulroney ; Black & White Photo: (Karlheinz) Schreiber ;

**Full Text (830 words)**

(Copyright National Post 1999)

Brian Mulroney, the former prime minister, has stepped up efforts to persuade Karlheinz Schreiber -- the man at the centre of the Airbus affair -- to release his confidential Swiss bank accounts to the Canadian government so the matter can finally be put to rest.

Mr. Schreiber's bank records are the missing piece of an RCMP investigation into allegations that he paid a \$5-million bribe to Mr. Mulroney, allegedly to ensure Air Canada bought \$1.8-billion worth of Airbus aircraft in 1988. Mr. Schreiber was alleged to be acting as a lobbyist for Airbus.

"Nothing would make Mr. Mulroney happier than to have these documents opened up so that his innocence would be clear forever," Luc Lavoie, Mr. Mulroney's spokesman, said yesterday.

This week, Mr. Mulroney telephoned his former chief of staff, Fred Doucet, from South Africa, where the former prime minister is vacationing with his family, and asked him to organize another approach to Mr. Schreiber.

Mr. Doucet persuaded a former cabinet minister in Mr. Mulroney's government, a man who knew Mr. Schreiber, to telephone him on Mr. Mulroney's behalf and ask that the documents be released.

Over the last three years, Mr. Mulroney has interceded with Mr. Schreiber several times, both directly in telephone calls, and through intermediaries.

But Mr. Schreiber has always been unreceptive. "I don't want to release the documents," he told the National Post, "because the whole procedure by the Canadian government is illegal, and I want to see them in court to prove this."

The RCMP investigation has been proceeding on and off since the Air Canada purchase of the Airbus aircraft 10 years ago.

In 1995, the probe gained momentum when a disgruntled former employee of Mr. Schreiber's alleged that Mr. Schreiber had told him he was going to bribe Mr. Mulroney.

The informant added that he did not know if a bribe had actually been paid, but supplied details of the bank account that supposedly received the money. His allegation was later proven false.

In 1995, the Canadian government sent a letter to the Swiss government asking for copies of Mr. Schreiber's own bank documents.

The Swiss only release such information when there's evidence of a crime. A Swiss police official advised the Canadian government how to word the letter so that it would seem to pass this stringent Swiss requirement.

The letter used very strong language, saying Mr. Mulroney has engaged in "criminal activity" to "defraud the Canadian government."

Mr. Mulroney launched a lawsuit for libel. In January, 1997, the Canadian government apologized, paid \$2-million of his legal fees, and declared the bribery allegation was "sans fondement" (without foundation).

But the letter of request to Swiss authorities was not withdrawn, and Mr. Schreiber began several legal actions to prevent his bank accounts being made public through the letter.

He first obtained a court order stopping the Canadian request from going forward in Switzerland, but that freeze order has since expired. This year, he asked the Federal Court in Vancouver to order the Canadian government to withdraw the letter of request.

"All we have asked the court to do is force the Canadian government to tell the Swiss government the truth," said Robert Hladun, Mr. Schreiber's Edmonton-based lawyer.

The court's ruling is expected in September. Meanwhile, in June, after the court-ordered freeze expired, the Canadian government reactivated the letter of request.

The Swiss attorney-general, Carla del Ponte, ordered the Schreiber bank documents released to Canada. She explained that she accepted the letter of request as if it was literally true.

The Swiss do not normally look behind a letter of request, lawyers explain. If there's a problem with a letter, Swiss policy is that the requesting country deals with the problem.

Mr. Schreiber countered with an appeal to the Supreme Court of Switzerland, called the Bundesgericht, to countermand Ms. del Ponte's order.

The basis of the Schreiber appeal is that Switzerland has no right to honour the letter of request, because it does not conform with Swiss requirements. The Swiss court has yet to deliver a ruling.

The Schreiber bank accounts will be released to Canada if both the Federal Court and the Bundesgericht rule against Mr. Schreiber. If either rules in Mr. Schreiber's favour, the Airbus affair will likely come to an end.

According to some estimates, Mr. Schreiber has spent about \$2- million in legal fees to prevent his bank documents from being released.

But Mr. Hladun says Mr. Schreiber has nothing to hide. "He's a man of integrity," he added, "and he values his privacy. It's a matter of principle."

Others doubt that anybody would spend so much money just to establish a point of principle.

Mr. Lavoie confirmed that Mr. Mulroney has asked Mr. Schreiber to release the bank accounts, but denies Mr. Mulroney is applying any pressure. "He doesn't want to infringe on anybody's right to go to court seeking justice," Mr. Lavoie said.

**[Illustration]**

Black & White Photo: (Brian) Mulroney ; Black & White Photo: (Karlheinz) Schreiber ;

**Indexing (document details)**

**People:** Mulroney, Brian, Schreiber, Karlheinz, Lavoie, Luc  
**Author(s):** Philip Mathias  
**Document types:** Business  
**Section:** News  
**Publication title:** National Post. Don Mills, Ont.: Aug 20, 1999. pg. A.3  
**Source type:** Newspaper  
**ProQuest document ID:** 250862221  
**Text Word Count** 830







Karlheinz Schreiber

The Right Honourable  
Brian Mulroney

Montreal

Ottawa, January 14, 2004

Fax 1 514 286 1238

Dear Brian,

From our friend in Nova Scotia I learned that you intended to meet with me.

I think it is a good idea to improve our way of communication.

There are a few important and urgent matters I would like to discuss with you also looking for your advise and support.

Please let me know which dates would be convenient for you for a meeting.

Best regards





Subj: **Re Proposed Letter**  
Date: 25/06/2006 5:29:07 P.M.: Eastern Standard Time  
From: [sharonmackay923@hotmail.com](mailto:sharonmackay923@hotmail.com)  
To: [Schreiberbarbel@aol.com](mailto:Schreiberbarbel@aol.com)

Dear Brian,

I wish to tender my profuse apologies to you for the misleading, erroneous and unfair characterization of your business relationship with me as depicted on the CBC program, "The Fifth Estate."

Without excusing my part, it is fair to say that I was misled by the producers that the program would deal with my complaints about the "sting" operation mounted against me by the RCMP.

May I state for the record, that my testimony under oath in prior legal proceedings is the only correct description of our business arrangement, that is to say, you, after returning to private life, at my request, agreed to advise and consult with me in certain business affairs. You were the best advocate I could have ever retained, and I am grateful for your efforts.

You and I have been the victims for a long time of a vicious, unfounded and totally misleading information. I am convinced that the past Liberal government, Stevie Cameron, Georgio Pelossi and the RCMP are all intertwined in a contemptible conspiracy. You know as well as I that this must be exposed; it will not go away unless strong actions are taken against those responsible.

Again, I apologize for my ambiguity and lack of caution in what I said on t.v. I was confused and upset, not any more!

Yours truly,

Karlheinz Shreiber.

## KARLHEINZ SCHREIBER

The Right Hon. Brian Mulroney, P.C., LL.D.

47 Forden Crescent  
Westmount Quebec

CANADA ....H 3 Y 2 Y 5

Ottawa July 20, 2006

Dear Brian,

Over the past three month I have learned a lot about the "monster" that has dogged our footsteps since 1994. Without a doubt, this is the biggest "Political Justice Scandal" in Canadian history.

The most recent statements under oath in court and during Examinations for Discovery have confirmed that Stevie Cameron, journalist, writer, confidential RCMP informant and complainant, had been passing information to the Mounties since 1988. She, together with a convicted Swiss criminal, Giorgio Pelossi, Canadian political figures and government officials are responsible for the "Political Justice Scandal" in Canada as well as in Germany and many other countries.

I also for the first time encountered a satisfying explanation regarding a very painful misunderstanding between us related to the "Bear Head Project".

You and I are the innocent victims of this vendetta and you are the still the prime target.

I have been trying since 1997 to bring the truth to light in a courtroom in Alberta, so far without success, due to the delay tactics of the Department of the Attorney General.

The "Political Justice Scandal" around the "Airbus Affair" will not go away by itself. The people behind the conspiracy must be exposed through determined actions and brought to justice. You and I have a responsibility towards our families, our friends, international companies involved, as well as to Canadians, to Canada and ourselves.

Despite the fact that I was very angry about the statements made by Norman Spector, Luc Lavoie and Bill Kaplan, I regret deeply that the people from the CBC's Fifth Estate were able to entrap me, just as they did so many others before me. This was possible with the help of an American journalist, whom I have trusted for a long time. He was misled, as was I.

I wish to tender my profuse apologies to you for the misleading, erroneous and unfair Characterization of your business relationship with me as depicted on the CBC program, "The Fifth Estate".

Without excusing my part, it is fair to say that I was misled by the producers that the program would deal with my complaints about the "sting" operation mounted against me by the RCMP.

May I state for the record, that my testimony under oath in prior legal proceedings is the only correct description of our business arrangement. You, after returning to private life, at my request, agreed to advise and consult me in certain business affairs.

I still believe that my statements in the book "The Secret Trial," together with my testimony under oath at the Eurocopter trial and my statements to Bob Fife, have made it crystal clear what my position is.

There is no "Airbus Affair" involving Brian Mulroney and furthermore there is nothing to hide.

The discussion and financial arrangements between you and me about future industrial projects have been correct, private and nobody's business. You were the best advocate I could have retained.

It is far too long since we had lunch together. I think it is wrong not to speak to each other. Too many people talk too much. I have not changed. I have always been your friend, even though I was irritated for some time, which I regret. For the sake of objectivity and fairness, I ask you to accept my apology.

I am happy that your health is fine again: so let us clear the air and bring peace to our families and ourselves.

Yours sincerely

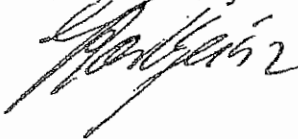



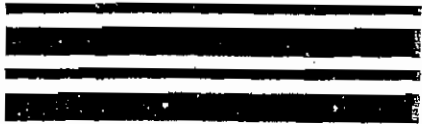

# SUPERText

RCMP/GRC "A" DIVISION A  
Commercial Crime  
Délits commerciaux  
Project/projet A102  
File/dossier: 95A517

## EXHIBIT INFORMATION

Date Seized: \_\_\_\_\_

Seized By: \_\_\_\_\_

Exhibit No.: \_\_\_\_\_

Item No.: \_\_\_\_\_

Sub-Location: \_\_\_\_\_

Location: \_\_\_\_\_

## DOCUMENT CATEGORIZATION:

Document Type: news article

Sub-file / Endorser Text: media

Original: Yes  No

COMMENTS: re: Chronicle Herald - Nova Scotia

doc date: Dec 5/2007

# The Chronicle Herald NOVA SCOTIA

Obituaries | Columnists | Blogs | Lot

**NEWS OPINIONS BUSINESS SPORTS ENTERTAINMENT LIVING**

Print E-Mail Digg This! Newsvine Share on Facebook

## Mackay: Just trying to help

Ex-Mulroney minister says letter to Schreiber attempt to mend split

By STEPHEN MAHER Ottawa Bureau

Wed, Dec 5 - 6:35 AM



OTTAWA — When Elmer MacKay drafted a letter of apology from Karlheinz Schreiber to Brian Mulroney, he said he was just trying to patch things up between his old friends.

"I put that thing together to try to ameliorate the problems between Mr. Schreiber and Mr. Mulroney," he said Monday night in the first interview he has given on the subject. "To be frank with you, both these men I like."

Elmer MacKay says he feels badly that the opposition has focused on his friendship with Brian Mulroney and Karlheinz Schreiber. (File)

The letter has been publicly quoted by Mr. Mulroney and his spokesman to show there was nothing wrong with the \$300,000 in cash payments Mr. Schreiber made to Mr. Mulroney.

Mr. MacKay, a cabinet minister in the Mulroney government who retired from politics in 1993, says if he is guilty of anything it is being unquestioningly loyal to his friends.

"I'm afraid I'll probably have to plead guilty to that," he said. "And it's not a good thing to do because another thing I've learned is no good deed goes unpunished. It sounds very cynical, but there's a lot of truth in it. If you want to get ahead, don't get involved with other people. Look after yourself. You'll be better off financially and you'll have more peace of mind."

Mr. MacKay said he feels particularly bad that the opposition has used his relationship with Mr. Schreiber to try to embarrass his son, Defence Minister Peter MacKay.

"I can't think of anything worse," he said. "There's no private conversations that Peter and I have had that are germane to this."

He said Peter MacKay did, as he has publicly stated, warn his father that he was "leery" of Mr. Schreiber.

"He has mentioned this to me. I don't think that Peter has any animosity or feels bad toward Karlheinz Schreiber. I think Peter felt I was getting into a possible situation where it would be better if I didn't get involved in Karlheinz's troubles."

Elmer MacKay said he knows nothing about the business relationship between Mr. Schreiber and Mr. Mulroney.

<http://thechronicleherald.ca/NovaScotia/996248.html>

Search:

MULTIMEDIA

TOP VIDEO



PLAY VIDEO

Pickton crim profit

ANNOUNCEMENTS

TODAY'S NEWS

No backup for  
Grit MPs: Au  
Man charged  
A big fracking  
Answers in A  
THE LEADER:  
C.B. hospital  
GOVERNMENT  
Loud and cle  
Mayor: Parer  
Man dead in

10/12/2007



In his last days as prime minister, in 1993, Mr. Mulroney sent a car to take Mr. Schreiber to the PM's residence at Harrington Lake, Mr. Schreiber told a Commons committee on Tuesday. They agreed that after Mr. Mulroney left office, he would work for Mr. Schreiber on the Bear Head project, an ultimately doomed plan to build an armoured vehicle factory in Cape Breton.

Mr. Schreiber had received \$10 million in "grease money" to spread around in Canada as a reward for landing a \$1.8-billion contract with Airbus. Some people close to Mr. Mulroney -- lobbyists Frank Moores and Fred and Gerry Doucet -- are alleged to have received some of that money.

Mr. Schreiber testified Tuesday that he was partly motivated by a desire to help Mr. Mulroney, who had had to repay \$150,000 when it was revealed that he and his wife, Mila, were trying to sell furniture from their official residence to the government.

"And that's because the problem was they sold the furniture and Fred Doucet was out of his mind, no money, and Elmer MacKay was nearly crazy that they took the furniture away," Mr. Schreiber said.

Mr. MacKay said Monday night that he never knew any details about the Airbus deal and was "completely amazed" when the story broke. He also said he was "not that close" to the Doucets.

Mr. MacKay has done a great deal for Mr. Schreiber. In cabinet, he fought for the Bear Head project, saying it would have been good for Cape Breton. When Mr. Schreiber was being sought by German authorities, Mr. MacKay flew to Switzerland to bring him back to Canada. When he was to be jailed pending extradition, Mr. MacKay posted \$100,000 bail for him and testified as to his good character.

Nobody has ever suggested that Mr. MacKay sought personal gain from any of his dealings with Mr. Schreiber. Many people familiar with the saga, including academic Donald Savoie, Senator Lowell Murray, Liberal MP Robert Thibault and journalist Stevie Cameron, have said they think it is unlikely that Mr. MacKay did anything wrong.

Mr. MacKay said he still likes Mr. Schreiber and doesn't know of any wrongdoing on his part.

He also said he greatly admires Mr. Mulroney, but people around him may have used their relationships with him.

"Brian Mulroney was a very open-minded person," he said. "He was what you could call a soft touch. And a lot of people used his name for things that they wanted done, and you know, this was not right."

( [smaher@herald.ca](mailto:smaher@herald.ca) )

ABOUT US | CHARITIES | CONTACT US | CONTESTS | PRIVACY POLICY | SUBSCRIPTIONS | WORK  
COMICS | FAQ | FEATURES | HIGHWAY CAMS | HOROSCOPE | LIBRARY SERVICES | LOTTERIES  
ADVERTISING | CLIENT UPLOAD | COMMUNITY HERALD MEDIA KIT (PDF) | HERALD MEDIA KIT (PDF) | SPC

© 2007 The Halifax Herald Limited



KARLHEINZ SCHREIBER

7 BITTERN COURT, ROCKCLIFFE PARK  
OTTAWA, CANADA K1L 8K9

TELEPHONE 613 748 7330  
FACSIMILE 613 748 9697  
schreiberbarbel@aol.com

The Right Hon. Brian Mulroney, P.C., LL.D.  
47 Forden Crescent

Westmount, Quebec  
H3Y 2Y5

Ottawa, January 29, 2007

Dear Brian,

I refer to my letter January 19, 2006 concerning the decision of The Hon. Vic Toews, P.C. M.P. then the Minister of Justice and Attorney General of Canada to support his predecessor The Hon. Irwin Cotler by denying the "Airbus" vendetta against you and your friends and the existence of the "Political Justice Scandal".

**This case is much worth and much more dangerous than the Maher Arar case.**

Imagine, a Liberal Minister of Justice initiates a political vendetta against a retired Conservative Prime Minister, his friends and the Conservative Party with the involvement of the officials of the Department of Justice, the RCMP, confidential informants and complainants, undercover agents from foreign agencies, journalists and foreign informants with criminal records.

Officials from the Department of Justice and the RCMP participate in an international political conspiracy, traveling during 12 years on taxpayer's money all over the world even violating the sovereignty of foreign countries. No confirmation concerning their allegations of fraud and bribe was found.

A victim of the vendetta files a lawsuit against the Minister of Justice and the Attorney General of Canada.

The vendetta caused an extradition case against the victim. The officials from the Department of Justice and the RCMP are trying to conceal the vendetta and the abuse of power and committed crimes through extradition or detention.

**I always thought that events like this belong to the political behavior in countries with totalitarian Governments.**

Since February 2006 Canada has a Conservative Government. The victim informed the Prime Minister, the Minister of Justice, the Minister of Foreign Affairs, the Minister of Public Safety and others, including you, about the ongoing vendetta.

On December 1, 2006 the Conservative Minister of Justice confirmed his predecessor's decision to extradite the victim to Germany required through Extradition - Treaty obligations. Every Minister involved and you know that this is a huge lie.

**THE CANADIAN - GERMAN EXTRADITION TREATY**

**ARTICLE V: EXTRADITION OF NATIONALS**

**(1) NEITHER OF THE CONTRACTING PARTIES SHALL BE BOUND TO EXTRADITE ITS OWN NATIONALS.**

**Germany will never extradite one of its Nationals to Canada. The German Constitution, Article 16 (2) will not allow the extradition of its Nationals.**

Dear Brian, can you please tell me why the Conservative Minister of Justice wants the Canadian National Karlheinz Schreiber, the victim, out of the country and help to conceal the biggest "Political Justice Scandal" in Canadian history contrary to the normal political interest of the Conservative Government.

**I do not believe that the Hon. Vic Toews, then the Minister of Justice and Attorney General of Canada, made this decision on his own. What is the political interest of the Conservative Government and the Prime Minister in this case and what are the benefits? Is there a serious concern about the possible result of an inquiry?**

Unfortunately, you did not respond to my letter as requested and it appears to me that you have no desire to bring any support to my request for a public inquiry which could bring the insanity to an end.

**All my personal problems began with Stevie Camerons book "ON THE TAKE" and Allan Rock's political witch-hunt with the RCMP against you.**

Since 1996 I am fighting to bring the truth to light through my lawsuit against the Attorney General of Canada. I never received any support from you despite the fact that I provided support at your request since the late 70s.

From 1985 until 1993 I had confidence in you and your statements concerning the Thyssen Bear Head project. You always told me to hang on and that the Thyssen project would go ahead as promised when the company was asked to come to Canada and provide jobs to the people in Nova Scotia.

During the year 2001 I could read in Stevie Cameron's book "The last Amigo" on page 260 that Norman Spector told RCMP officers : Prime Minister Brian Mulroney killed the Thyssen project in 1990 or 1991. Paul Teller and Bob Fowler were looking after the business interests of General Motors London Ontario.

This was some time after Thyssen Bear Head Industries signed agreements concerning the projects with the Federal Government and the Provincial Government of Nova Scotia and Thyssen had paid substantial amounts of Dollars to GCI Frank Moores related to the achievements.

You never told Elmer Mackay or me that you killed the project and I went on working on it to fulfill your promises to bring jobs to the people in Nova Scotia.

During the summer of 1993 when you were looking for financial help, I was there again. When we met on June 23, 1993 at Harrington Lake, you told me that you believe that Kim Campbell will win the next election. You also told me that you would work in your office in Montreal and that the Bear Head project should be moved to the Province of Quebec, where you could be of great help to me. We agreed to work together and I arranged for some funds for you.

Kim Campbell did not win the election, but we met from time to time.

At the beginning of November 1995 I informed you about the letter of request from the Canadian Department of Justice (the IAG) to the Swiss Department of Justice.

Some days later your wife Mila was extremely concerned about you and told me that you are considering committing suicide. I was shocked and spoke to you for quite a while and you may recall that I told Mila to buy a little lead pipe to cure the disease.

I did not understand what your problem was since the Airbus story was a hoax as I told Bob Fife from the Sun. When I look back and consider what all you have done in the meantime I have the suspicion that there must be something else of great concern to you.

When we met in Zuerich, Switzerland on February 2, 1998 at the Hotel Savoy, I left with the impression that you were in good shape.

On October 17, 1999 you asked for an affidavit or assurance from me which confirms that you never received any kind of compensation from me.

At the beginning of October 1999 to my great surprise I learnt that your spokesman Luc Lavoie told Harvey Cashore: "*Karlheinz Schreiber is the biggest fucking liar the world has ever seen. That is what we believe!*"

Believing the story, I got from you through a friend, I filed a lawsuit against the CBC which I had to drop when I got to know the truth and listening to the tapes. The fee: \$ 50.000.

During the Christmas Holydays 1999 I visited Fred Doucet at his home and told him that he should tell you that I would not commit perjury if I would have to testify and that I cannot understand why you don't simply tell the truth. A few days later, when I met with Fred again, he asked me to sign certain agreements concerning our business relationship. I refused to do so.

On January 24, 2000 Mila sent a letter to Baerbel and wrote: "the truth is certainly the best weapon!" She was right. If you would have taken her advice, you might have avoided a lot of trouble for you.

Until now you have to recognize that the Vendetta is not going away by itself.

During the summer of 2006, you again asked for a certain letter from me to be able to support my case, which I have sent to you on July 20, 2006 for your meeting on July 30, 2006.

When I look at the news during the last week and the activities from last year within the Department of Justice, concerning your settlement with the Government, I have a certain idea why your meeting was very important.

To assure that we have the same understanding about my case:

#### The Decision to Surrender

The judicial phase of the extradition process is a determination only that the evidence is sufficient to warrant that the person be extradited. The ultimate decision with respect to whether the person will, in fact, be surrendered to the extradition partner is that of the Minister of Justice.

When you look at my extradition case you have to agree with me that Baerbel's and my life is in the hands of the Minister of Justice and the Prime Minister or the IAG, who can arbitrarily decide since they have no obligation to extradite me to Germany.

Since the Minister of Justice decided on my surrender he must have a special reason to do so. What is the reason, becomes the most interesting question.

Dear Brian, I would like to ask you what the reason might be in your opinion, besides this I think it is in your and my best interests that you show up and help me now and bring this insanity to an end. If I am forced to leave Canada this will not end the matter.

Yours sincerely

A handwritten signature in cursive script, appearing to read "Brian".

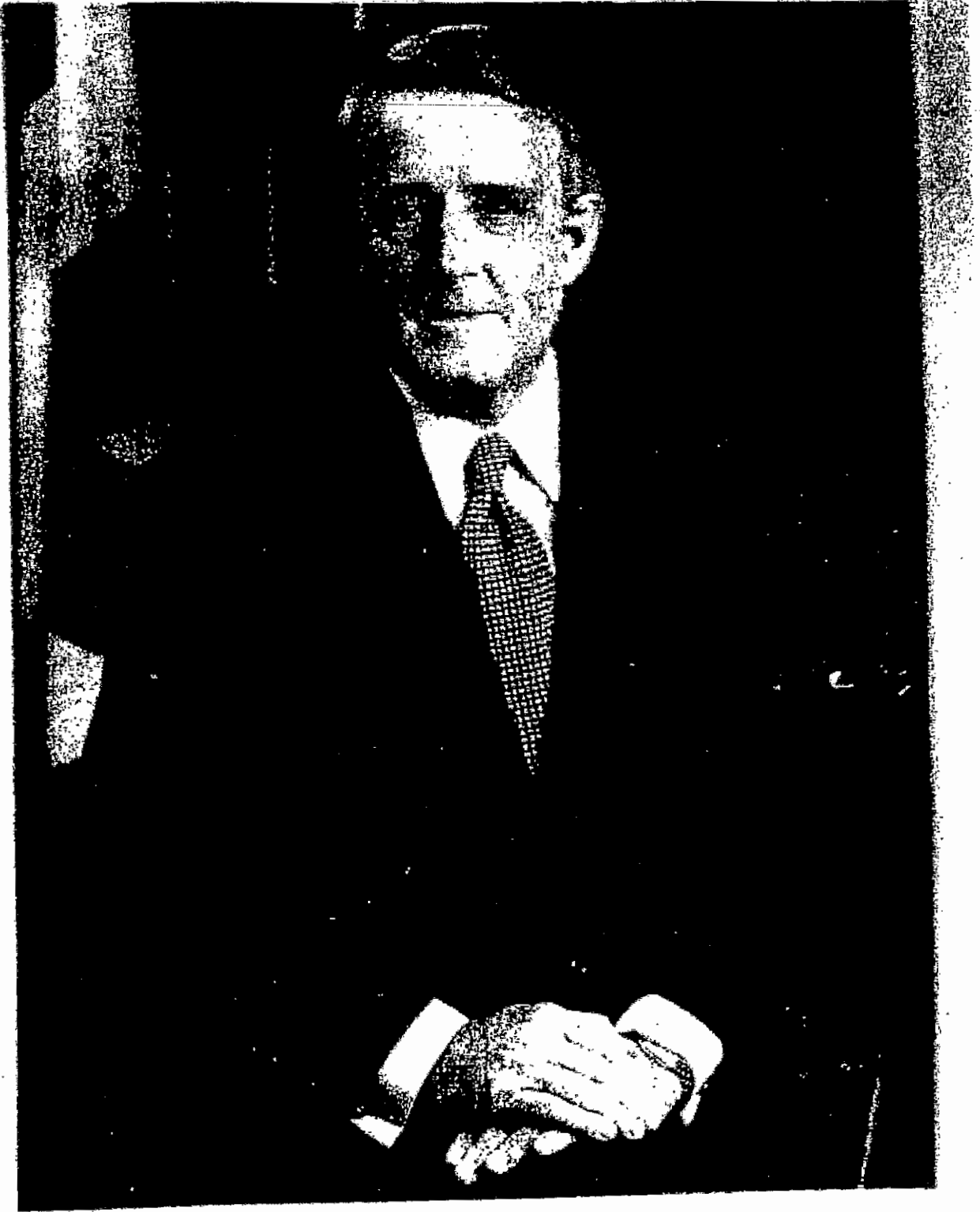

*for my friend, Karl Heinz  
with gratitude and best personal regards  
Günter Hubert*





Memo to the Prime Minister  
From E.M.

Subject: Bear Head Thyssen Project

Prime Minister:

I thought it useful to bring you up to date on this project. The representatives of Thyssen have been in Ottawa and have conducted a number of meetings with officials and myself which has given us all a better insight into the project.

We know that to kickstart this important facility Thyssen has sought a basic order of 250 vehicles - not only to assure a start-up production, but even more importantly to build upon the strength of a Canadian Defence order to trigger export sales to other Nato countries. Obviously, the first step has always been to establish a DND need for a product produced by Thyssen.

The good news is that the Army identifies a definite need for the product (the multi-role combat vehicle MRCV). Whatever the future look of the forces, and whatever the eventual environment in the European and world theatres, there will always be a need for the light vehicle capability, in Europe or Canada, in peacekeeping missions or in combat. Furthermore, the Army believes that the need is immediate in some cases. From all I have been able to learn, the Thyssen vehicle is especially adaptable to many uses. The present need applies to our present peacekeeping commitments. The MRCV would bring to our Canadian soldiers a sufficient level of protection which, I might add, our boys do not enjoy today. A very real present threat exists to the lives of our troops because today's commonly used machine gun ammunition easily pierces our current Canadian vehicles; sufficient protection is overdue. I am personally satisfied that the army feels the MRCV will be at the forefront of its priorities.

From a business point of view, Canada will never export ships or submarines, nor main battle tanks, nor military aircraft. The one area where we have an export window to NATO countries is the MRCV.

However, there are still steps to be overcome. The political will is clear, the Opposition is for it, ACOA believes this could be to Eastern Nova Scotia what Michelin is to the rest of Nova Scotia etc. The Deputy Minister at DND, who has the budget responsibility for DND's budget, has stated that there is no requirement for the vehicle. His position gives him enormous efficiency in opposing the project because he is eventually the one who gets to brief Stanley Hartt, his Minister, or Mr. Tellier. All initiatives eventually come to his door. The exact reasons for his resistance are not known (perhaps a resistance to political direction, a budgetary concern, an attempt to force his political masters to revise dollar reference levels?).

Fowler is technically correct. A requirement is a technical status given to a need. First, a need is recognized. Eventually, when DND finishes its analysis of needs, it

establishes priorities and budgets, and eventually issues the formal statement of requirement. Thus, there is not now any "requirement" for the vehicle.

The question becomes: can this need be fastracked to the requirement stage? We know that one day DND will have to purchase these vehicles and as things now stand, they may well have to buy them from the Thyssen plant which would have been established in the US.

A meeting was held on February 5, 1990, between Thyssen and Defense. The purpose was to explore the army's need and Thyssen's capacity to produce the vehicle. The army people were there, as were the Chief of Defense Staff, Healy, and Fowler. There was general agreement, we believe, that Thyssen could produce the vehicle. The Deputy spent much time explaining that while the army may describe a need for the MRCV, there was no **requirement** - and was vague on when that need would become a requirement. The Army people appeared muzzled but did admit there was a need, and acknowledged the compatibility of Thyssen's TH 495 in meeting that need.

I have since learned from reliable sources that the Army people present were in fact muzzled. They were told not to openly admit the need. This is very confidential information.

I have concluded that to proceed I must enlist the active collaboration of Paul Tellier and have the intention of asking him to come into service, unless you think otherwise.

I shall keep you posted.

Sincerely

EM

1000

1000

1000

1000

1000

1000

1000

1000



Minister                      Ministre  
Ottawa, Canada K1A0A4

SECRET

The Right Honourable Brian Mulroney  
Prime Minister of Canada  
Room 309-S, Centre Block  
House of Commons  
Ottawa, Ontario  
K1A 0A3

My dear Prime Minister:

I am writing to provide you with a brief update on the proposal by Thyssen Industrie A.G. of West Germany to establish a heavy-industry manufacturing facility in Cape Breton, and to seek your concurrence to communicate to the company, the Government's wish that the facility be oriented primarily not on military production as had originally been envisaged, but rather on production for civilian -- specifically environmental -- markets.

As you will recall, the proposal by Thyssen to establish a facility in Cape Breton was considered by Cabinet in the fall of 1988. Cabinet authorized the signing of an "Understanding in Principle" between the Government and the company which outlined a series of events and undertakings to provide for the establishment in Cape Breton of a facility to be based initially on military production.

More recently, however, my officials have been informed that the Canadian military procurement of the type Thyssen was pursuing will not proceed, although the company continues to believe that a significant military-vehicle contract from the Government is still a possibility.

In the interests of advancing the Thyssen proposal, and thereby realizing as soon as possible the very considerable economic benefits that would accrue to Canada and Nova Scotia, if you agree, it would be my intention to indicate to the company the Government's interest in seeing the facility proceed, but based on a civilian rather than a military footing.

.../2

Canada

001973

As you know, Thyssen is one of the world leaders in technologies related to pollution abatement equipment for thermal electric power generation, for water treatment and for solid waste management. Developing and enhancing Canadian capacity in all these fields will be a key part of our commitment to sustainable development. By attracting a firm like Thyssen to set up its North American "environmental" division at Bear Head we could score in three ways -- on the environment, on free trade and on regional development.

Should we be able to interest Thyssen in establishing a heavy-industry facility based on civilian production, I will request my officials, in consultation with representatives of other key departments, to negotiate a tentative arrangement with the company which could be shortly be brought forward to Cabinet for formal consideration.

In conclusion, I remain confident that the Thyssen proposal would provide immediate and significant economic benefits to Nova Scotia and beyond, and also that, should the environmental approach be successful, Canada would realize a significant step forward in achieving its environmental objectives.

Yours sincerely,

Elmer MacKay

001974.